

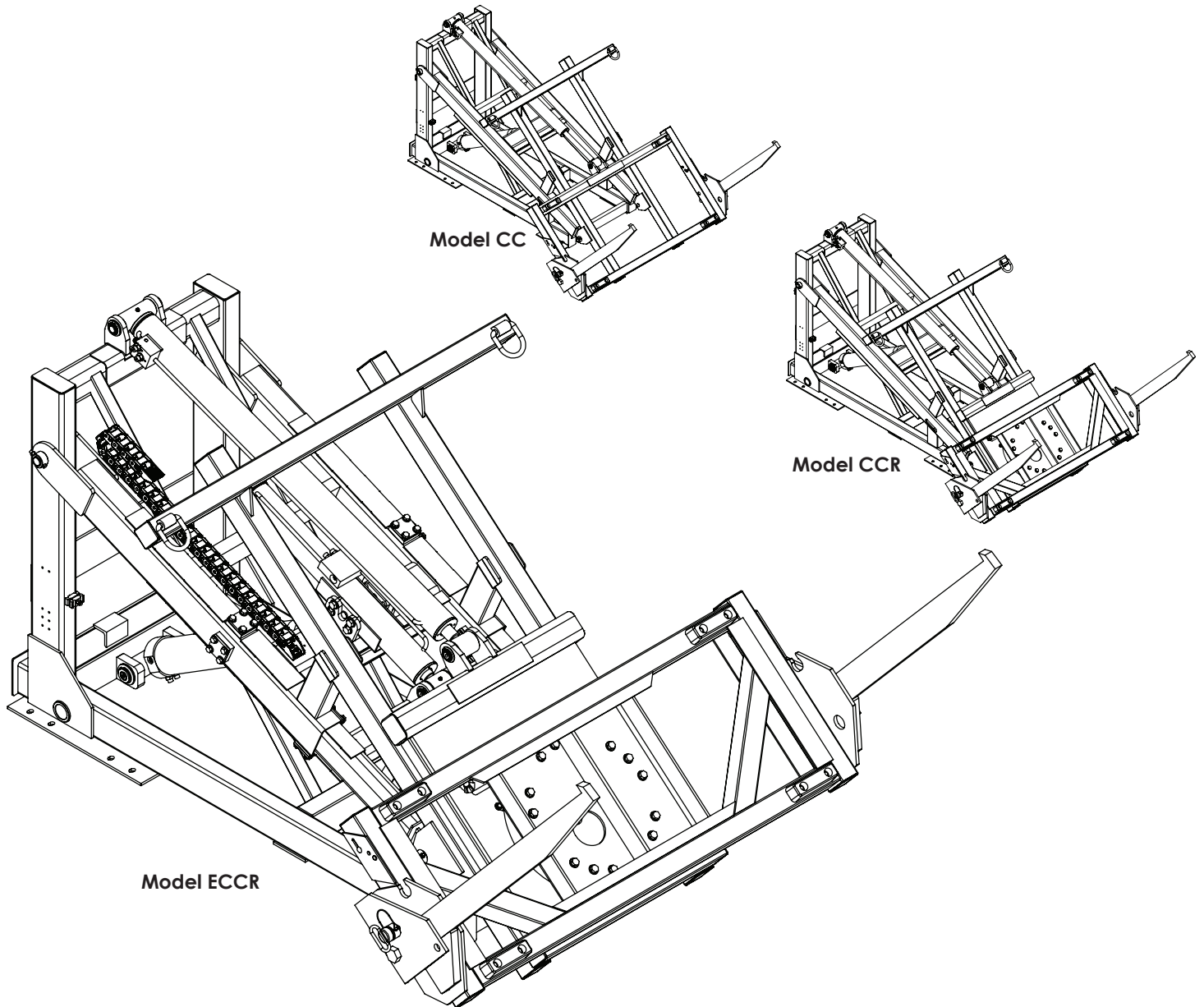

# CONTAINER CARRIER

## GENERAL MANUAL

Safety • Operation • Maintenance



**Stellar Industries, Inc.**

190 State Street

PO Box 169

Garner, IA 50438

800-321-3741

Fax: 641-923-2811

[www.stellarindustries.com](http://www.stellarindustries.com)

Subject to Change without Notification.  
© 2018 Stellar Industries, Inc.

Rev 1  
PN 89044

# Stellar® Container Carrier Manual Revisions

Date of Revision	Section Revised	Description of Revision

**⚠ WARNING** Operating, maintaining, and servicing a Stellar product may expose you to chemicals including, but not limited to, engine exhaust, carbon monoxide, phthalates, and lead. These chemicals are known to the State of California to cause cancer and birth defects (or other reproductive harm). To keep your exposure to a minimum, be sure to avoid breathing exhaust and service your Stellar product in a well-ventilated area while wearing gloves or washing your hands frequently. For more information, go to [www.P65Warnings.ca.gov/passenger-vehicle](http://www.P65Warnings.ca.gov/passenger-vehicle).

## Serial Tag Location

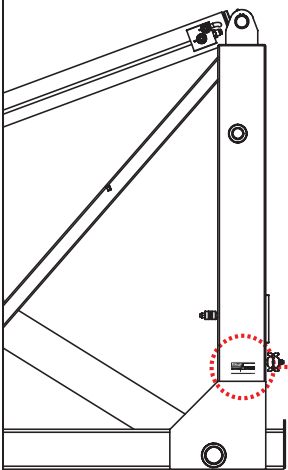



**PATENT INFORMATION**  
<http://www.stellarindustries.com/ip>

DATE

MODEL NO.

SERIAL NO.

**MADE IN THE U.S.A. BY STELLAR INDUSTRIES, INC.**  
PN C5942

# Table of Contents

---

Introduction.....	iv
<b>Chapter 1 - Operation .....</b>	<b>5</b>
General Operation.....	5
Operator Requirements .....	5
Pre-Operation Inspection .....	6
Job Site Setup .....	6
Container Carrier Controls .....	7
Lifting a Front Load Container .....	8
Placing a Front Load Container .....	12
Lifting a Rear Load Container.....	15
Placing a Rear Load Container.....	20
Lifting a Large Rear Load Container.....	23
Operation of Rotator .....	29
<b>Chapter 2 - Maintenance.....</b>	<b>31</b>
Basic Container Carrier Inspection Schedule .....	31
General Maintenance Guidelines .....	32
Hydraulic Oil/Filter Maintenance.....	32
PTO and Pump Maintenance .....	33
Model CC and CCR Grease Locations .....	33
Model ECCR Grease Locations .....	34
CCR & ECCR Gear Bearing Grease .....	35
Choice Lubricants for DX Bearings .....	36

# Introduction

A copy of this manual is provided with every crane and can be found in the hard plastic manual case that is installed on the chassis. A copy of this manual shall remain with the crane at all times.

Throughout the manual, three signal words will be used to bring attention to important items:

## **NOTICE**

A NOTICE signal word indicates a practice not related to physical injury.

## **⚠ WARNING**

A WARNING signal word indicates a hazardous situation which, if not avoided, could result in death or serious injury.

## **⚠ DANGER**

A DANGER signal word indicates a hazardous situation which, if not avoided, will result in death or serious injury.

Information contained within this manual does not cover specifications, installation, or contain assembly drawings. Please refer to your model specific Owner's Manual for details on these items.

This manual is not binding. Stellar Industries, Inc. reserves the right to change, at any time, any or all of the items, components, and parts deemed necessary for product improvement or commercial/production purposes. This right is kept with no requirement or obligation for immediate mandatory updating of this manual.

In closing:

If more information is required or technical assistance is needed, or if you feel that any part of this manual is unclear or incorrect, please contact the Stellar Customer Service Department by phone at 800-321-3741 or email at [service@stellarindustries.com](mailto:service@stellarindustries.com).

**For Technical Questions, Information, Parts, or Warranty, Call Toll-Free at  
800-321-3741**

Hours: Monday - Friday, 8:00 a.m. - 5:00 p.m. CST

Or email at the following addresses:

**Technical Questions, and Information**

[service@stellarindustries.com](mailto:service@stellarindustries.com)

**Order Parts**

[parts@stellarindustries.com](mailto:parts@stellarindustries.com)

**Warranty Information**

[warranty@stellarindustries.com](mailto:warranty@stellarindustries.com)

# Chapter 1 - Operation

Safety should be the number one thought on every operator's mind. Three factors should exist for safe operation: a qualified operator, well-maintained equipment, and the proper use of this equipment.

This chapter contains information regarding the safety and operation of Stellar® manufactured Container Carriers and should be read and understood completely by everyone working with or near the container carrier before putting the unit into operation.

**⚠ WARNING** Failure to follow operating, maintenance, or safety instructions can result in death or serious injury.

## General Operation

It is the responsibility of the owner to instruct the operator in the safe operation of the equipment and to provide the operator with properly maintained equipment.

**⚠ WARNING** Stellar® Container Carrier operators must conform to the qualifications specified in this manual. Trainees or untrained persons shall be under the direct supervision of qualified persons.

Operators shall consult with the owner of the equipment regarding current safety regulations and required personal protective equipment.

Operators should never operate the container carrier while under the adverse influence of alcohol, drugs, or medication.

Please take note that Stellar Industries, Inc. is not liable for accidents incurred by the container carrier because of non-fulfillment from the operator's side of current rules, laws, and regulations.

## Operator Requirements

### Operation is limited to the following people:

- A. Qualified individual.
- B. Trainees under direct supervision of the qualified individual.
- C. Test or maintenance individual.
- D. Container Carrier Inspector.

### Qualified individuals must:

- A. Demonstrate the ability to understand all decals, the owner's manual, and any other information required for safe operation of the container carrier.
- B. Be able to demonstrate the ability to safely control the container carrier.
- C. Know all safety regulations.
- D. Be responsible for maintenance requirements.
- E. Understand and be fully capable of implementing all emergency procedures.
- F. Understand all operating procedures as outlined by this manual.

## Pre-Operation Inspection

Before operating the equipment, make sure all regular maintenance has been performed. Each day, inspect the container carrier for all of the following:

- Hydraulic reservoir oil level.
- Hydraulic hoses and tubing for evidence of damage such as blistering, crushing, or abrasion.
- All safety covers for proper installation.
- Equipment for missing, illegible, or defaced operating decals and safety signs.
- Structural weldments for bends, cracks, or breaks.
- All pins and keepers for proper installation.
- Presence of this owner's manual.
- All pins, bushings, shafts, and gears for wear, cracks, or distortion to include all pivot points, and bushings.
- Fork stop pins are securely in place.
- Trunion bar stops are free to move and work properly.
- Replace/repair as necessary prior to operation.

## Job Site Setup

Thoroughly plan the lift by understanding the work site area and your loads before positioning the vehicle. Consider the following:

- Know the weight of your load to avoid overloading the equipment.
- Only use the container carrier to lift Stellar approved containers.
- **⚠️ WARNING** Do not overload the container carrier. Never exceed manufacturer's load ratings. These ratings are based on the machine's hydraulic, mechanical, and structural design rather than stability. Know the container carrier components and their capabilities and limitations. Overloading the container carrier may result in serious damage of self, others, equipment or the surroundings.
- **⚠️ WARNING** Do not allow unauthorized personnel or equipment to enter within 10 feet of container carrier operating area. The vehicle should be positioned in an area free from bystanders and overhead obstructions. Use a signal person if necessary.
- **⚠️ DANGER** Always maintain safe clearance from high voltage power lines. Death or serious injury will result from inadequate clearance if container carrier, load, or vehicle becomes electrically charged.
- Make certain that the vehicle is parked on stable, flat ground as close to the job as possible. The surface under the service truck must be able to support the weight of the machine and its load. Take care when operating in areas supported by vehicle tires, because of the cushioning effect of springs and tires.
- **⚠️ WARNING** Do not operate the container carrier during electrical storms.
- In dusty work areas, every effort must be taken to keep dust and sand out of the moving parts of the machinery.
- In high humidity work areas, keep parts as dry as possible and well lubricated.

# Container Carrier Controls

## CONTROLLER ASSEMBLY

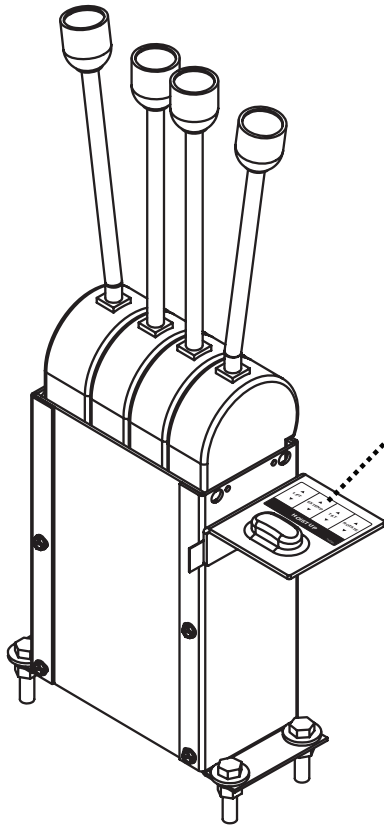

ECCR

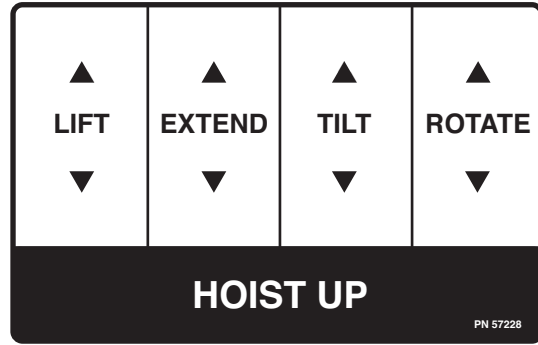

CCR

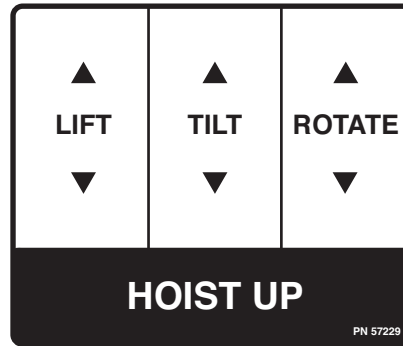

CC

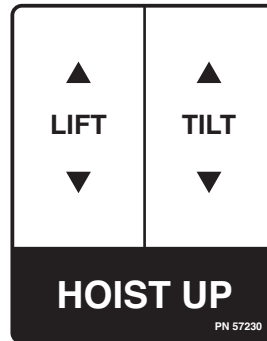

Be familiar with the sequence and operation of the container carrier controls.

Each individual container carrier function should have control function decals. Replace them immediately if they are missing or illegible.

Keep hands, feet and control levers free from mud, grease and oil.

Be familiar with the control levers and how they operate before attempting to operate the container carrier.

Move the control lever slow and smooth for steady oil flow. Avoid jerky or sudden movement of the controls.

Be constantly aware of the container carrier position when operating the controls.

In extreme cold, operate the controls slowly to allow for viscosity changes.

# Lifting a Front Load Container

## Step 1

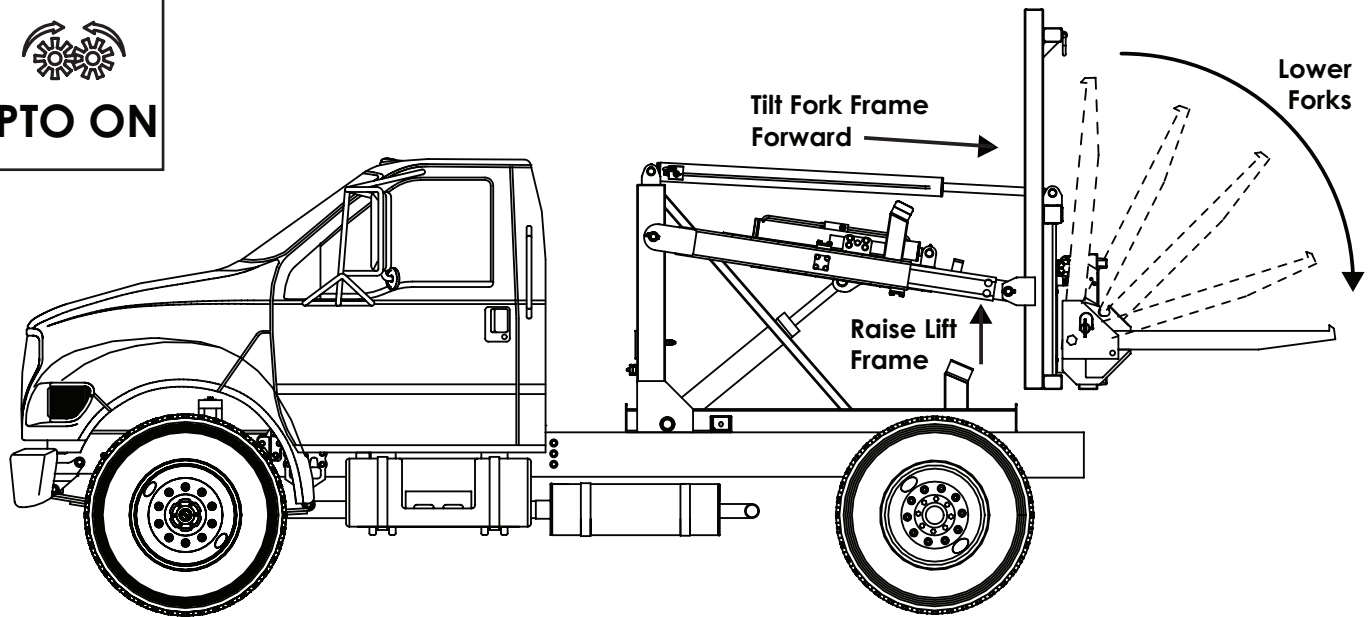

1. If the forks are in the stored position, engage the PTO and raise the lift frame high enough to clear the truck frame. Tilt the fork frame forward to allow easy manual rotation to the down position. Lock the forks into place with the fork stop pins.

**⚠ WARNING** Be sure that the area in which the container carrier is to be operated is clear of personnel and obstacles overhead and on the ground.

## Step 2

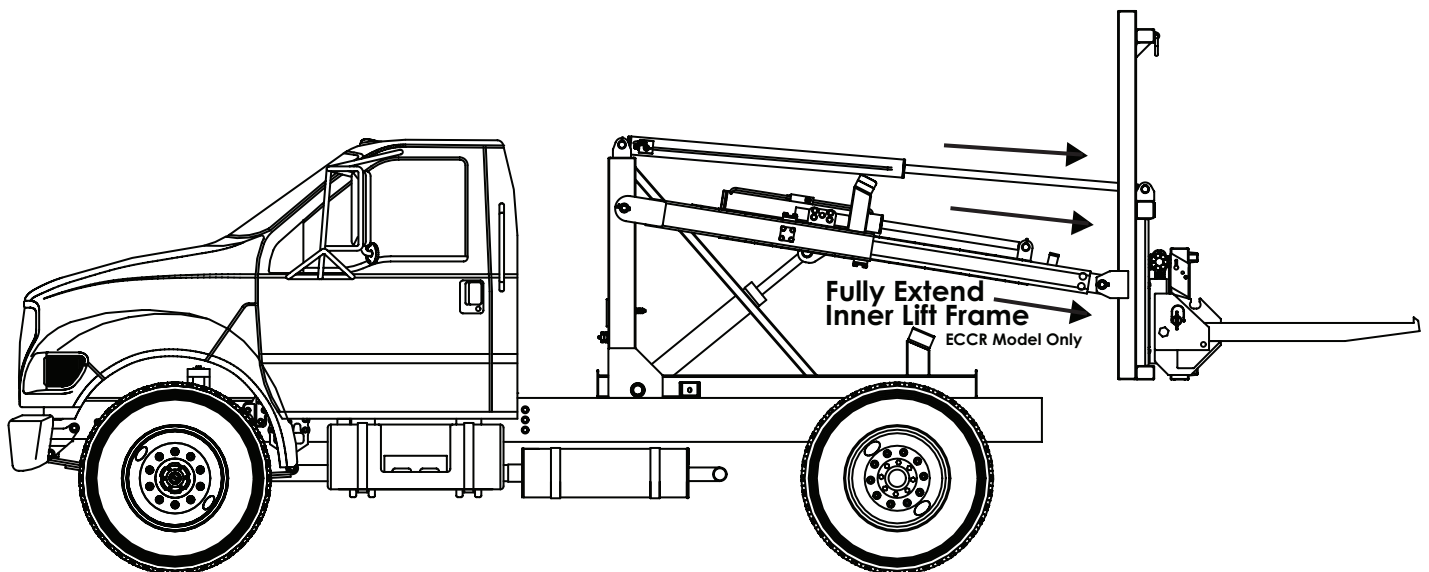

2. Fully extend the inner lift frame (ECCR Model Only).



# Lifting a Front Load Container

## Step 3

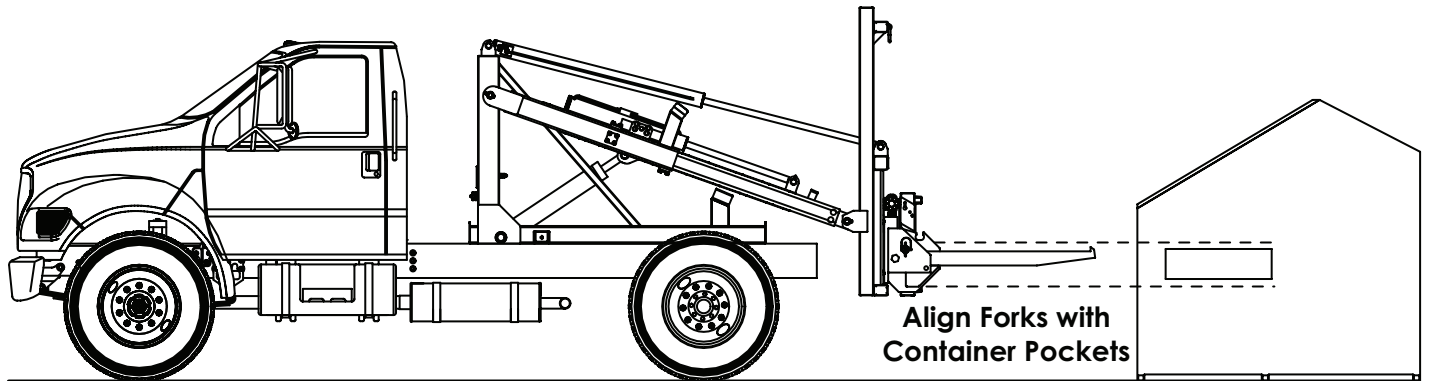

3. Align the forks with the container pockets by lowering the lift frame and tilting the fork frame.

### **NOTICE**

Do not push on fixed objects.

## Step 4

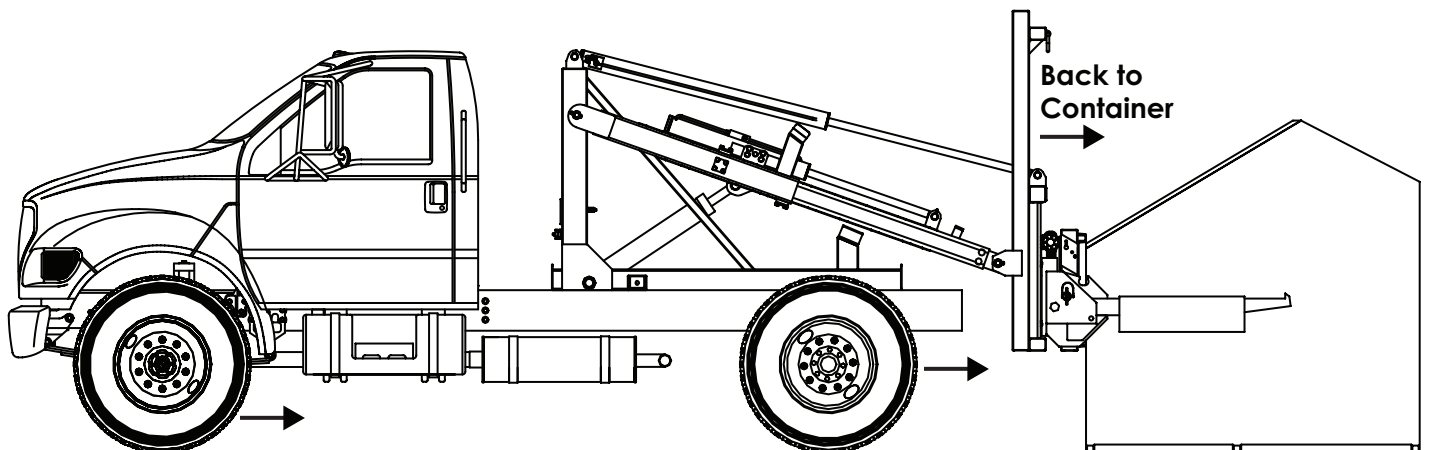

4. Slowly back the truck up to the container. Continue backing until the forks extend through the pockets and the container contacts the bumpers on the fork frame.

### **⚠ WARNING**

Do not use the container carrier to move personnel.

# Lifting a Front Load Container

## Step 5

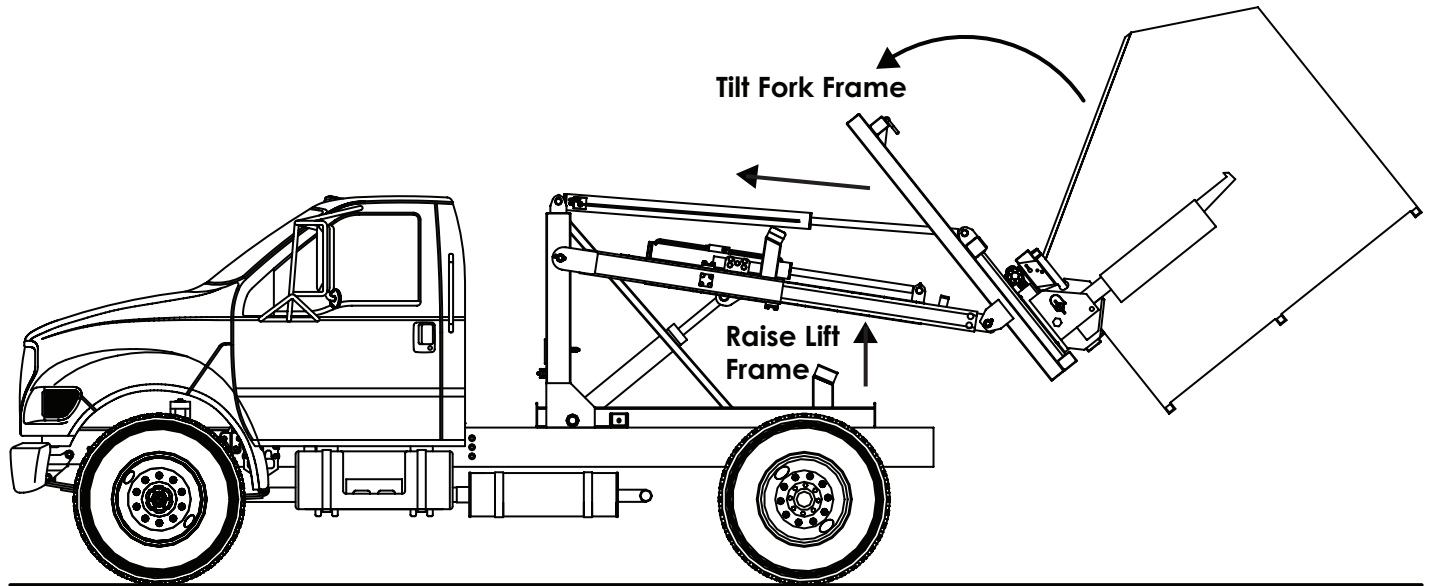

5. Raise the lift frame and tilt the forks up high enough to clear the truck frame.

## Step 6

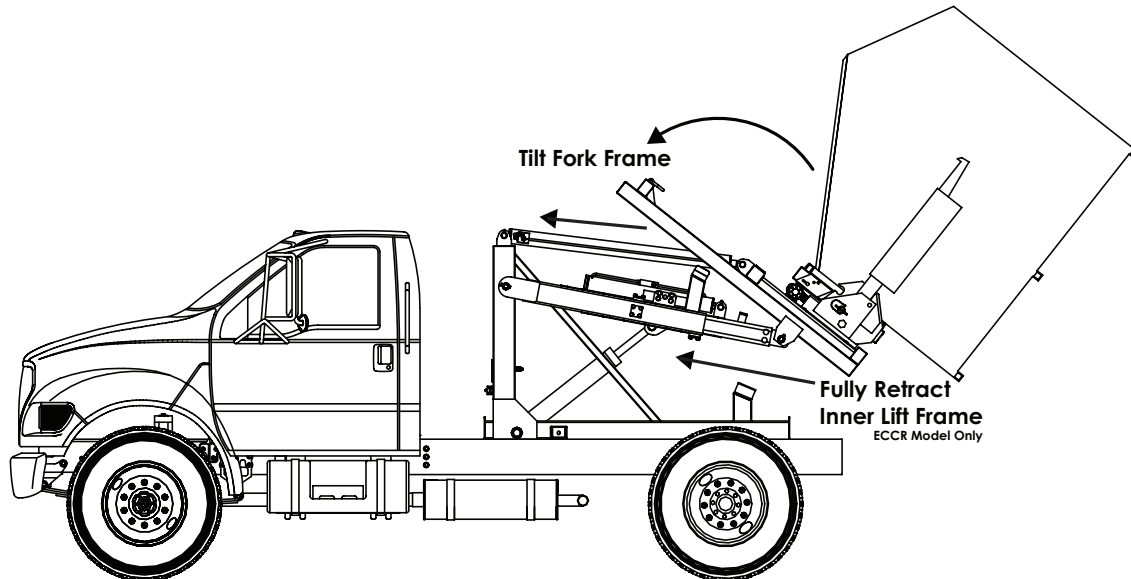

6. Fully retract the inner lift frame (ECCR Model Only). Tilt the fork frame all the way up so that full contact is made with the rest pads.

# Lifting a Front Load Container

## Step 7

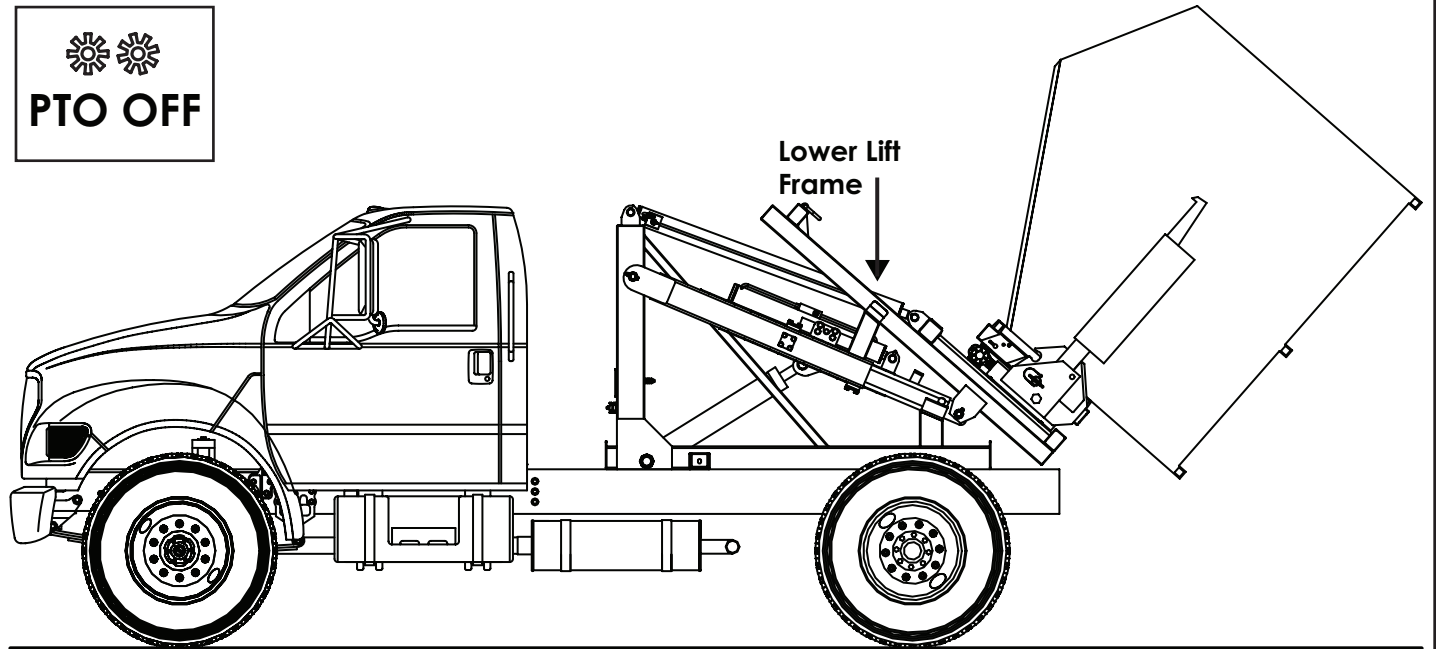

7. Lower the lift frame completely and disengage the PTO. Note: Check local DOT lighting regulations before transporting.

# Placing a Front Load Container

## Step 1

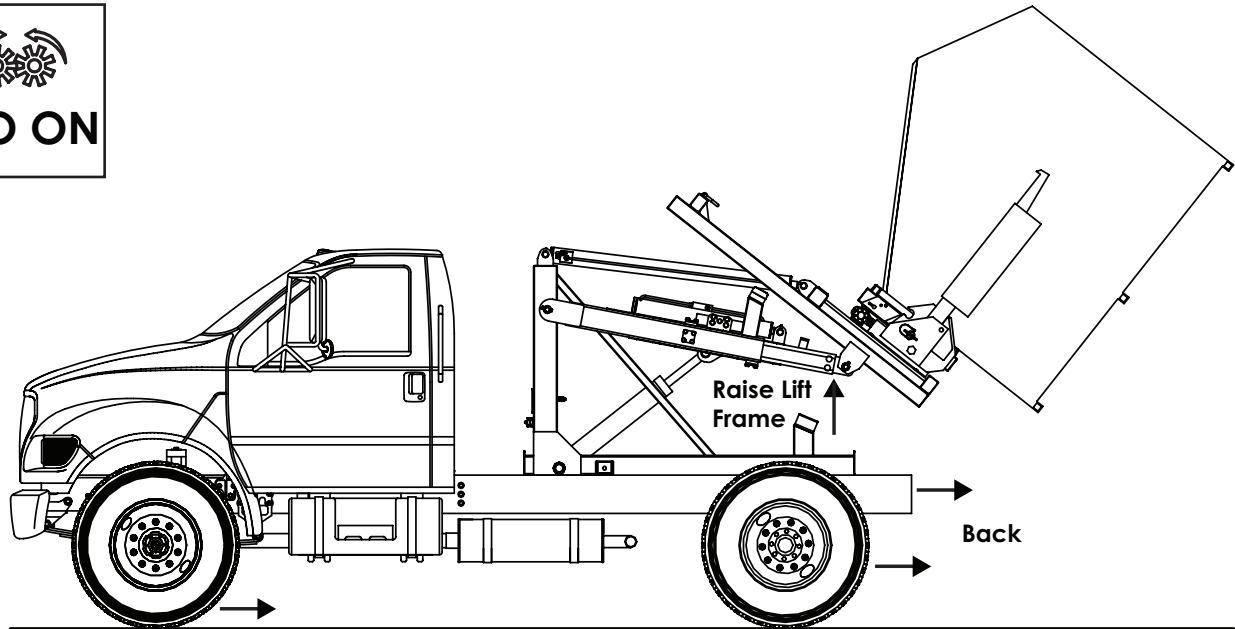

1. Back the truck up close to where the container will be placed. Engage the PTO and raise the lift frame high enough to clear the truck frame before tilting the fork frame.

**⚠ WARNING** Be sure that the area in which the container carrier is to be operated is clear of personnel and obstacles overhead and on the ground.

## Step 2

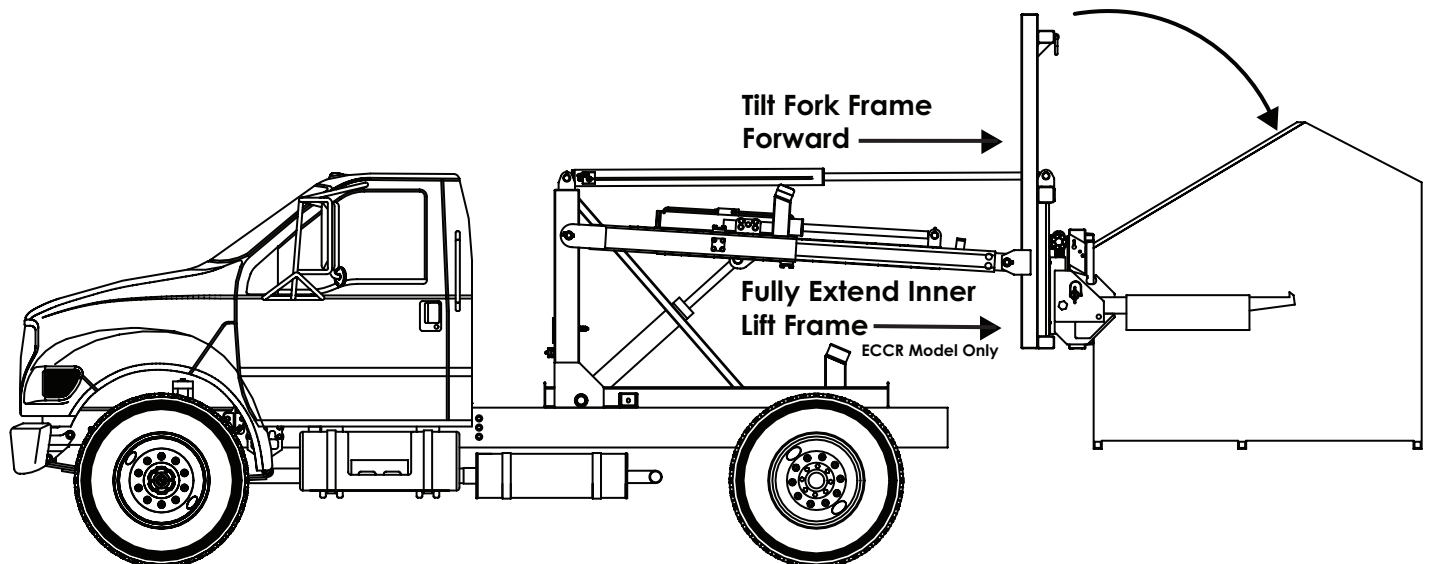

2. Tilt the fork frame forward until the container is parallel with the ground. Fully extend the inner lift frame (ECCR Model Only).

# Placing a Front Load Container

## Step 3

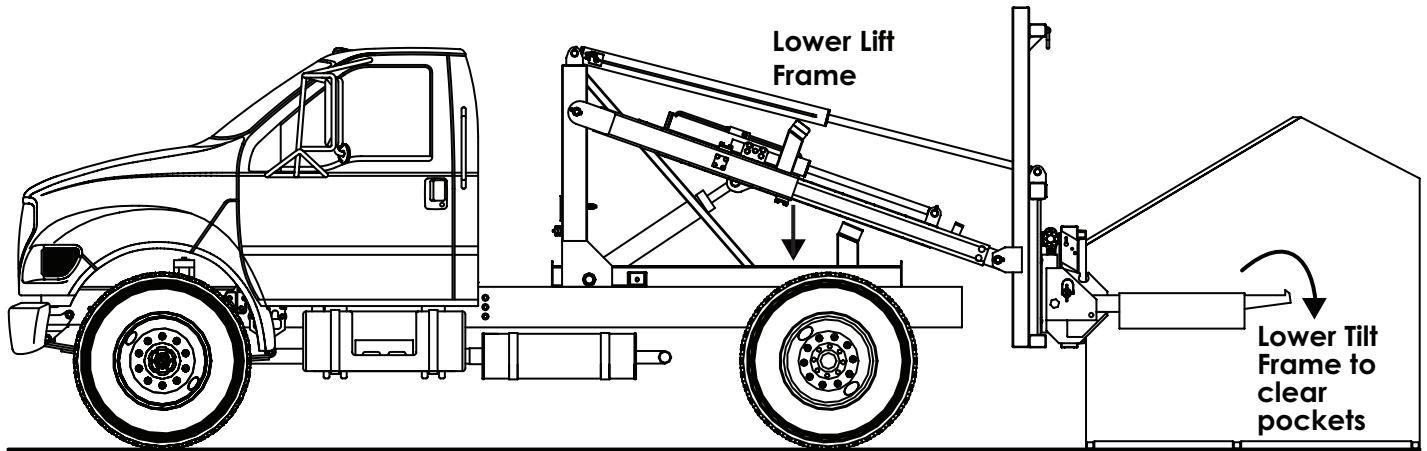

3. Lower the lift frame until the container is fully rested on the ground. Tilt the forks down enough to clear the container pockets.

## Step 4

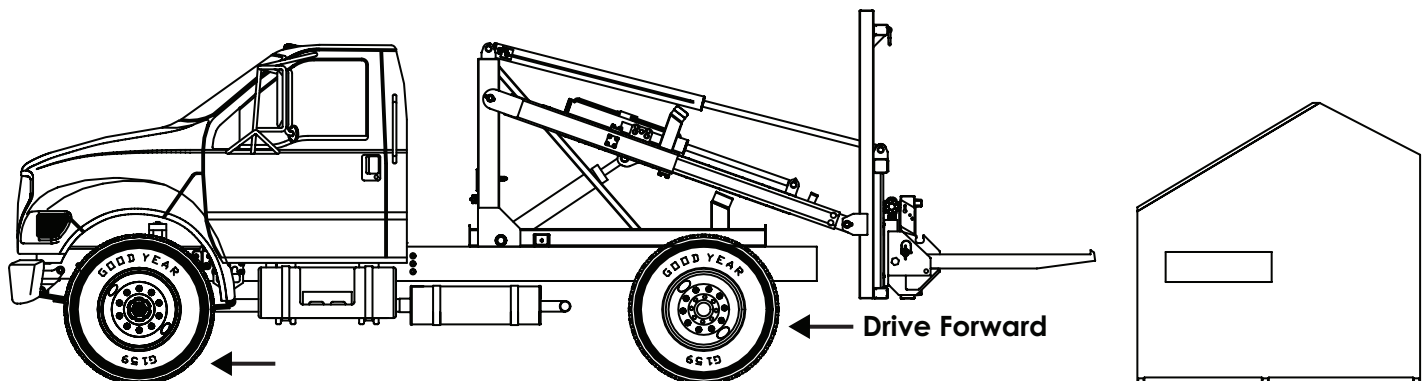

4. Slowly pull the truck forward until the forks are completely clear of the container pockets.

# Placing a Front Load Container

## Step 5

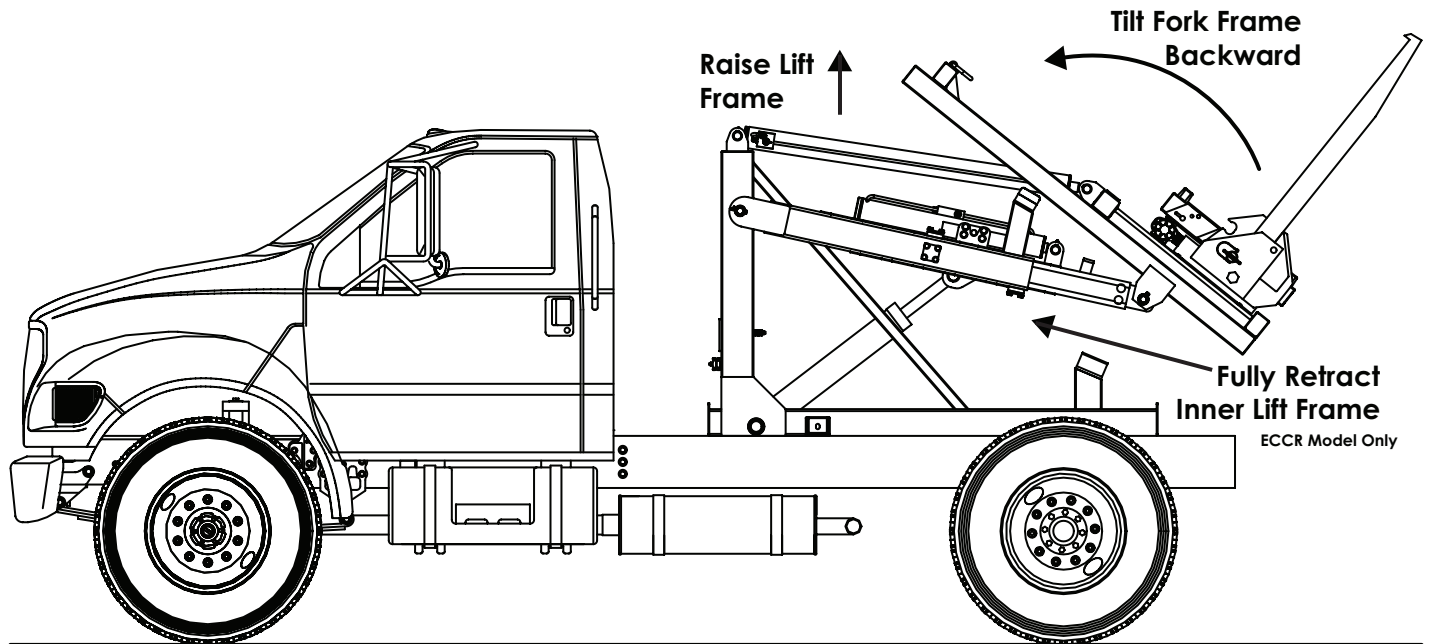

5. Raise the lift frame high enough to clear the truck frame. Fully retract the inner lift frame (ECCR Model Only) and tilt the forks all the way up so that full contact is made with the rest pads.

## Step 6

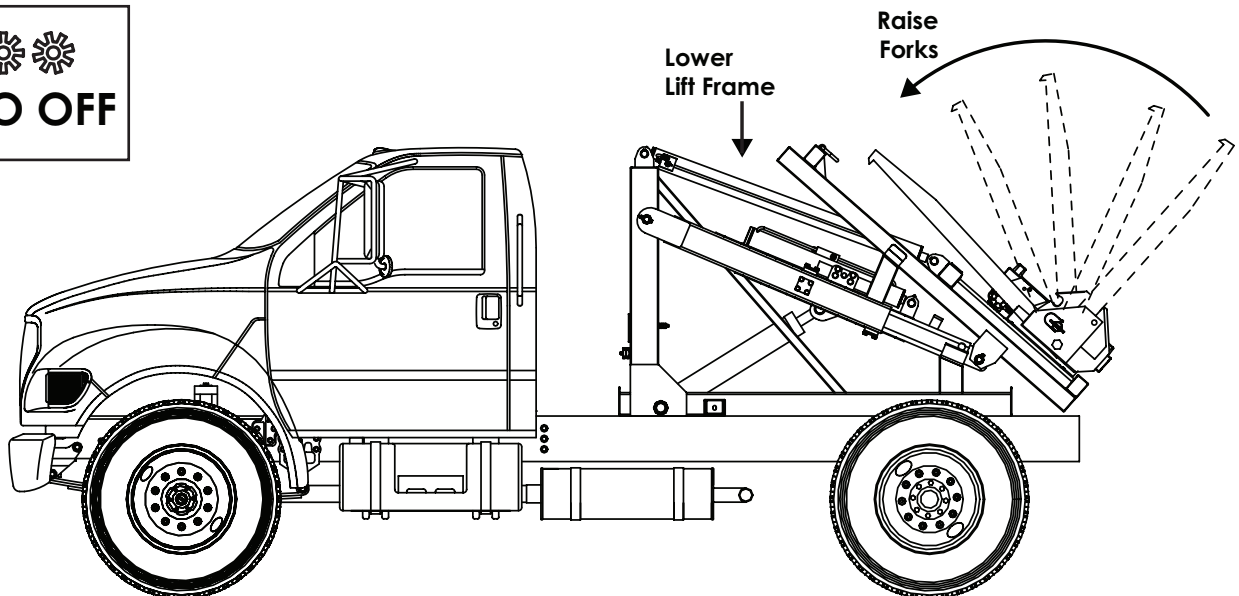

6. Lower the lift frame completely and disengage the PTO. Raise forks and lock in upright position.

# Lifting a Rear Load Container

## Step 1

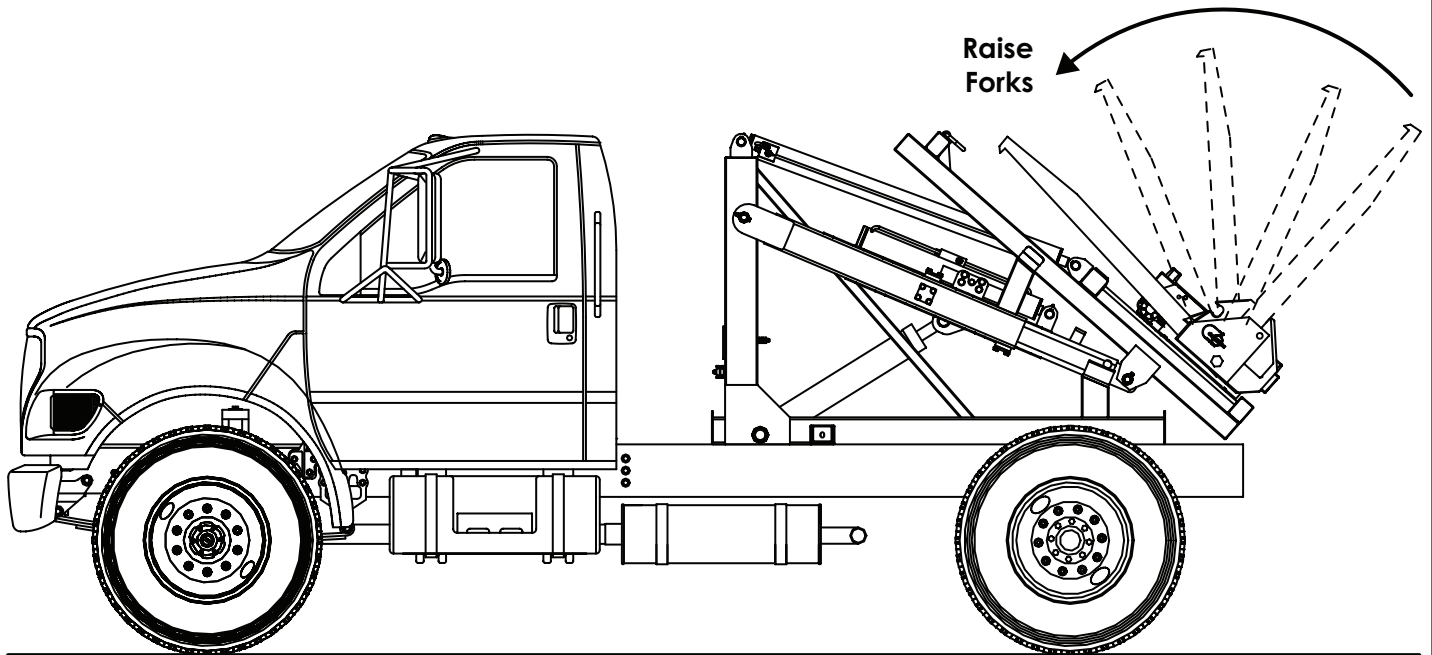

1. If the forks are in the extended position, manually rotate them to the stored position. Lock the forks in place with the fork stop pins.

**⚠ WARNING** Be sure that the area in which the container carrier is to be operated is clear of personnel and obstacles overhead and on the ground.

## Step 2

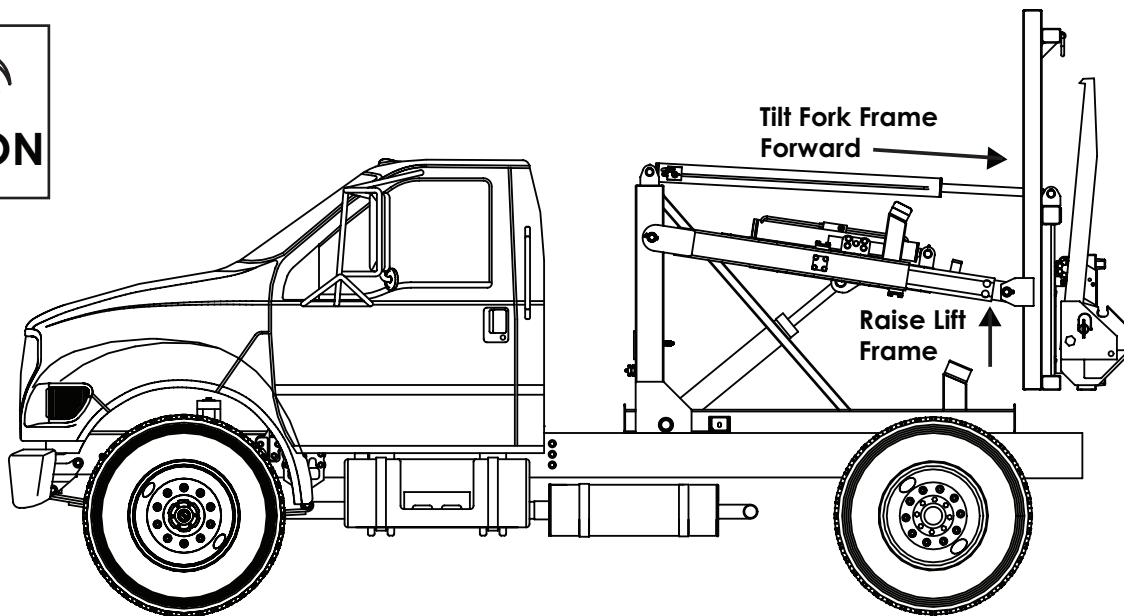

2. Engage the PTO and raise the lift frame high enough to clear the truck frame. Tilt the fork frame forward.

# Lifting a Rear Load Container

## Step 3

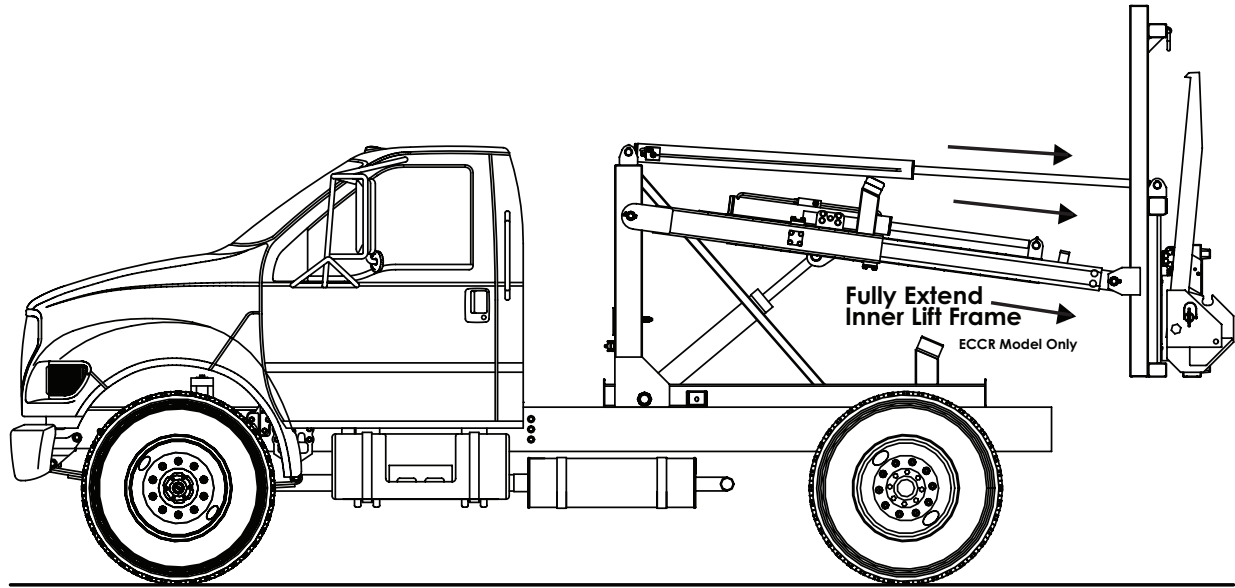

3. Fully extend the inner lift frame (ECCR Model Only).

## Step 4

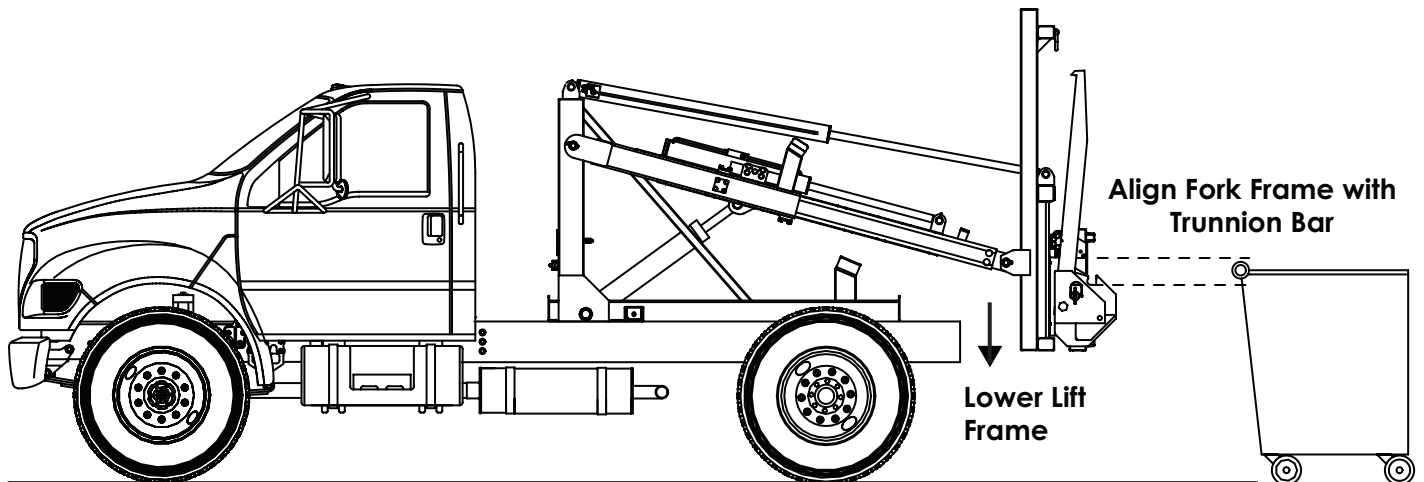

4. Align the fork frame with the trunnion bar on the container by lowering the lift frame and tilting the fork frame..



# Lifting a Rear Load Container

## Step 5

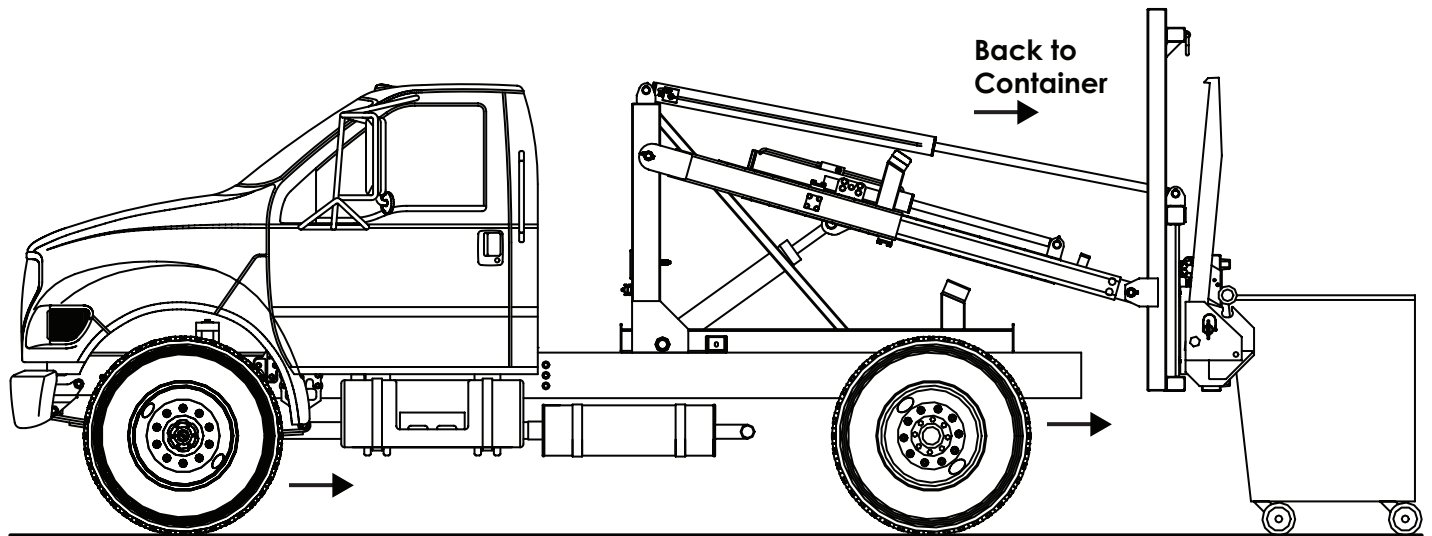

5. Slowly back the truck up to the container.

## Step 6

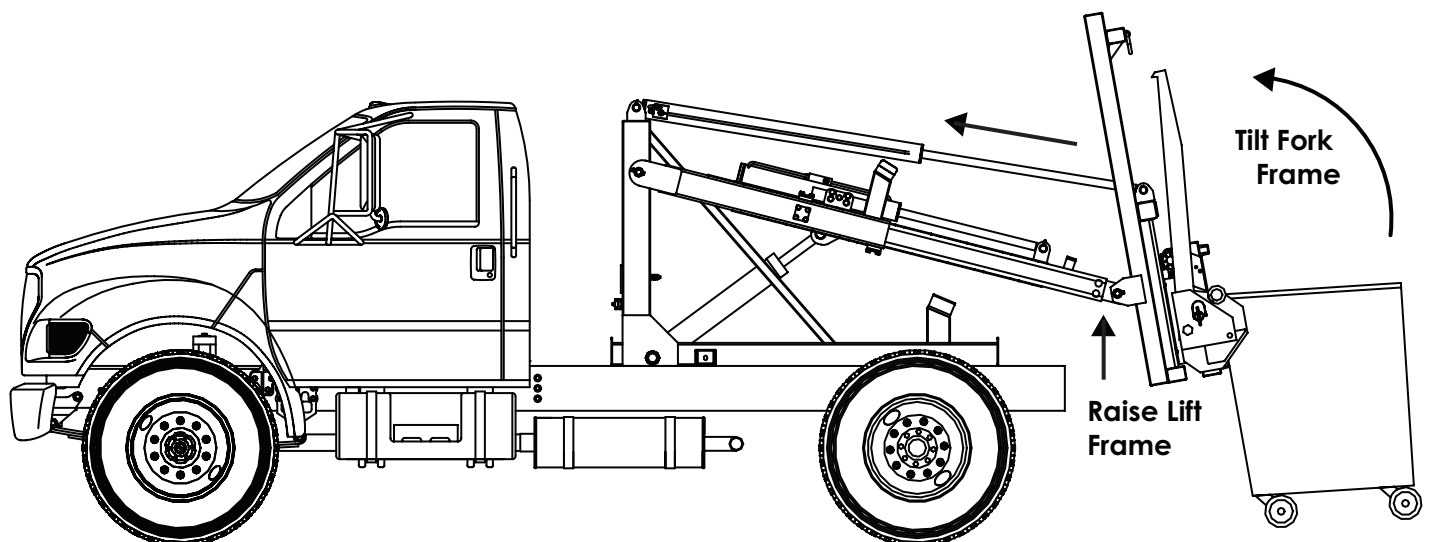

6. Raise the lift frame until the trunnion bars are securely located in the slots. Tilt the fork frame up until the container contacts the rubber bumpers. Put both trunnion bar stops in the 'locked' position (See next page).

# Lifting a Rear Load Container

Note: Trunnion Bar Stops

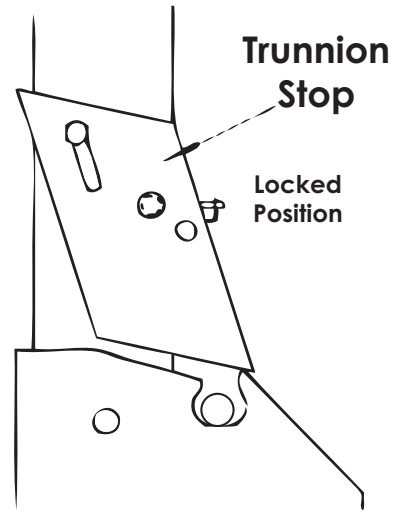
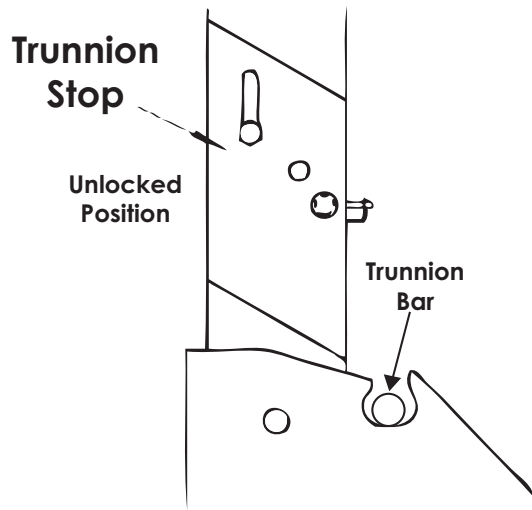

## Step 7

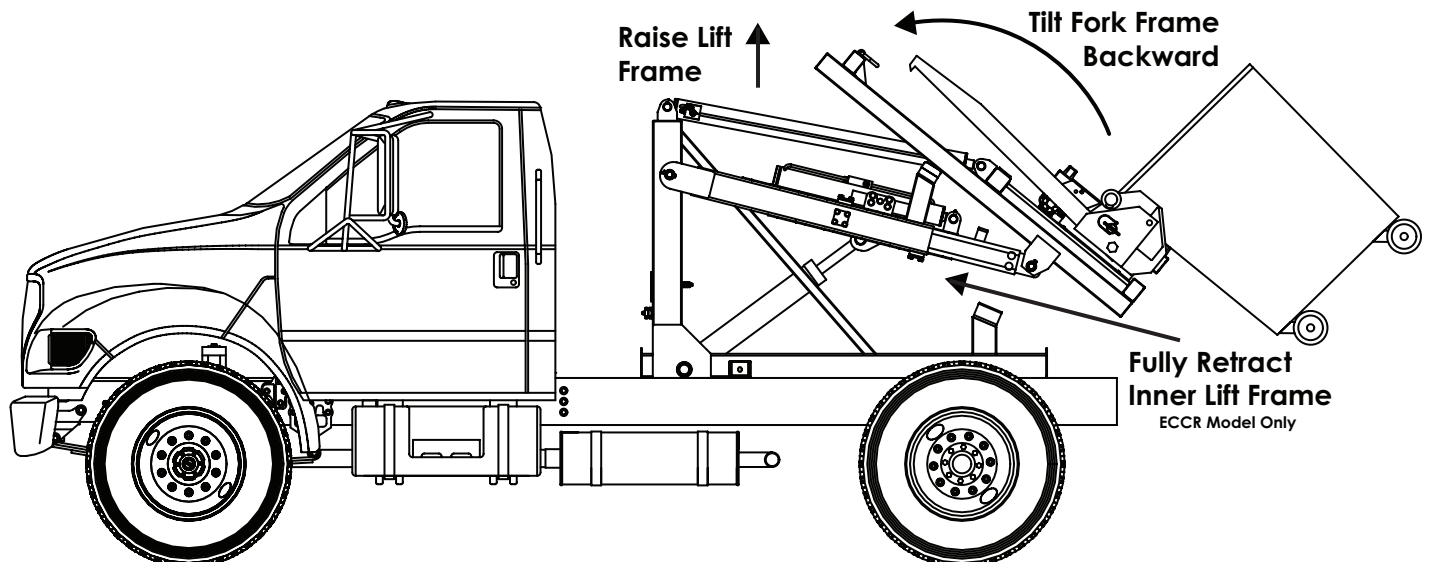

7. Raise the lift frame high enough to clear the truck frame. Fully retract the inner lift frame (ECCR Model Only). Tilt the fork frame all the way up so full contact is made with the rest pads.

# Lifting a Rear Load Container

## Step 8

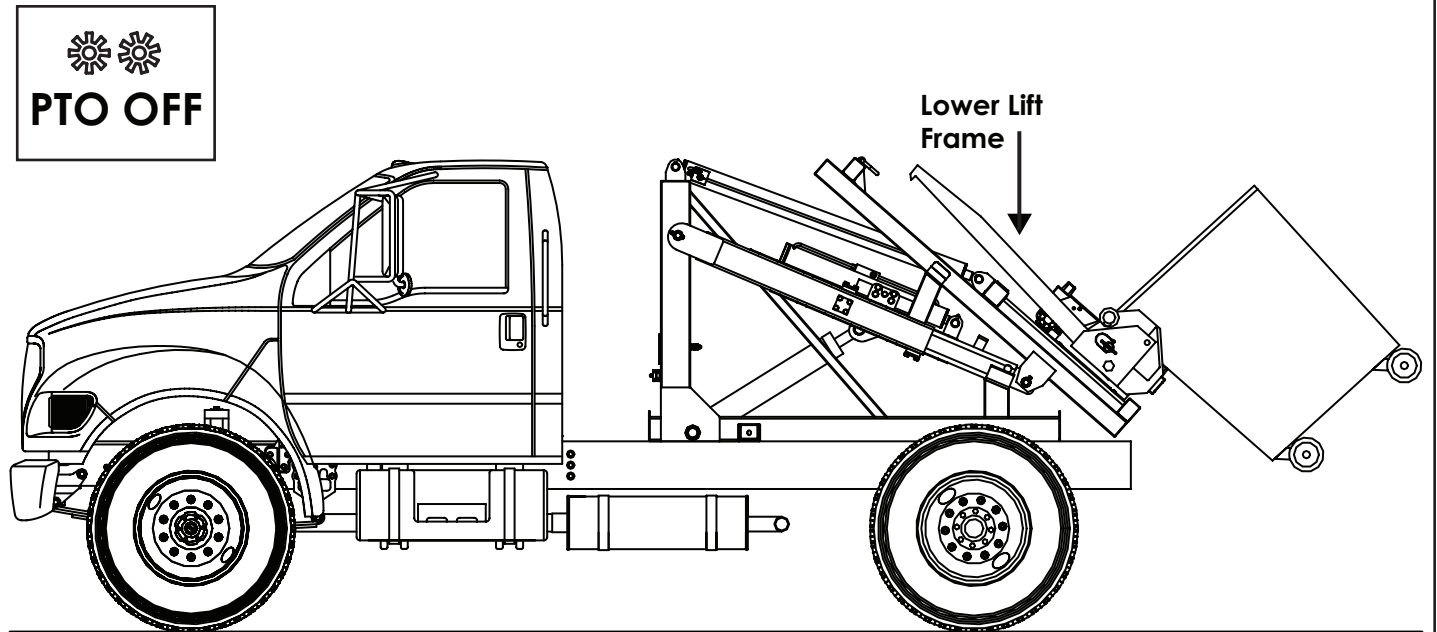

8. Lower the lift frame completely and disengage the PTO. Note: Check local DOT lighting regulations before transporting.

# Placing a Rear Load Container

## Step 1

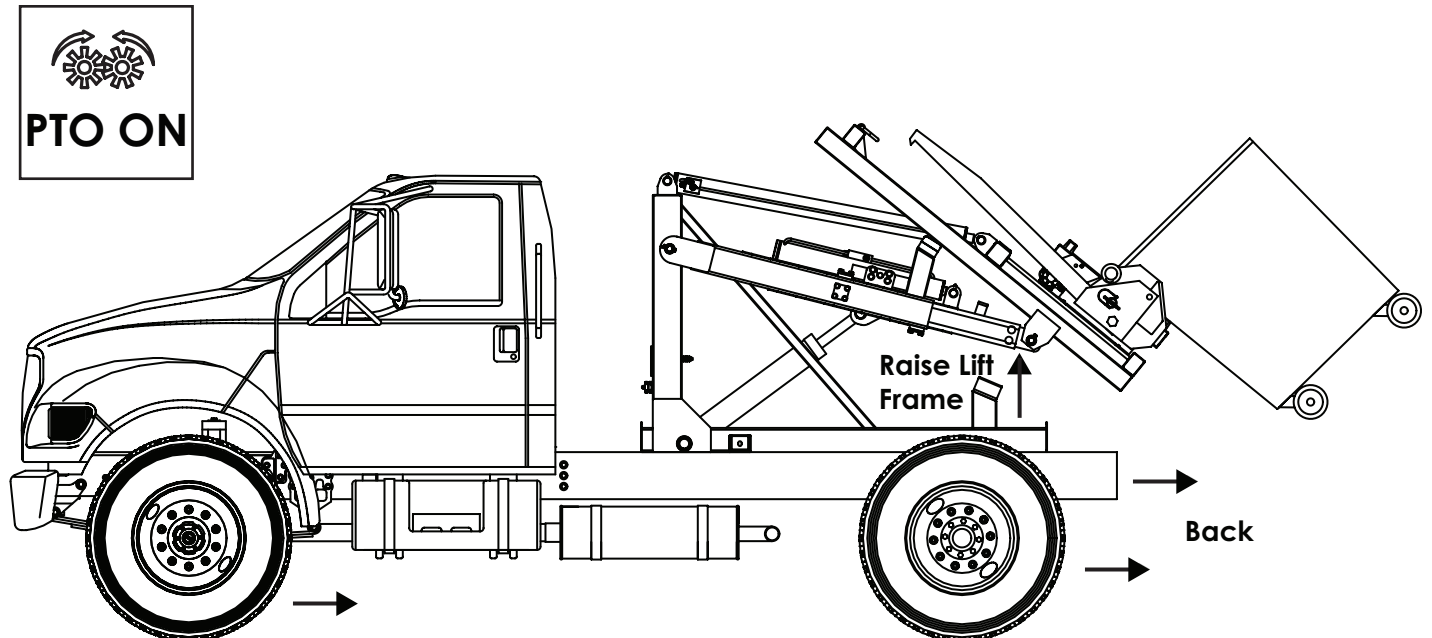

1. Back the truck up close to where the container will be placed. Engage the PTO and raise the lift frame high enough to clear the truck frame.

**⚠ WARNING** Be sure that the area in which the container carrier is to be operated is clear of personnel and obstacles overhead and on the ground.

## Step 2

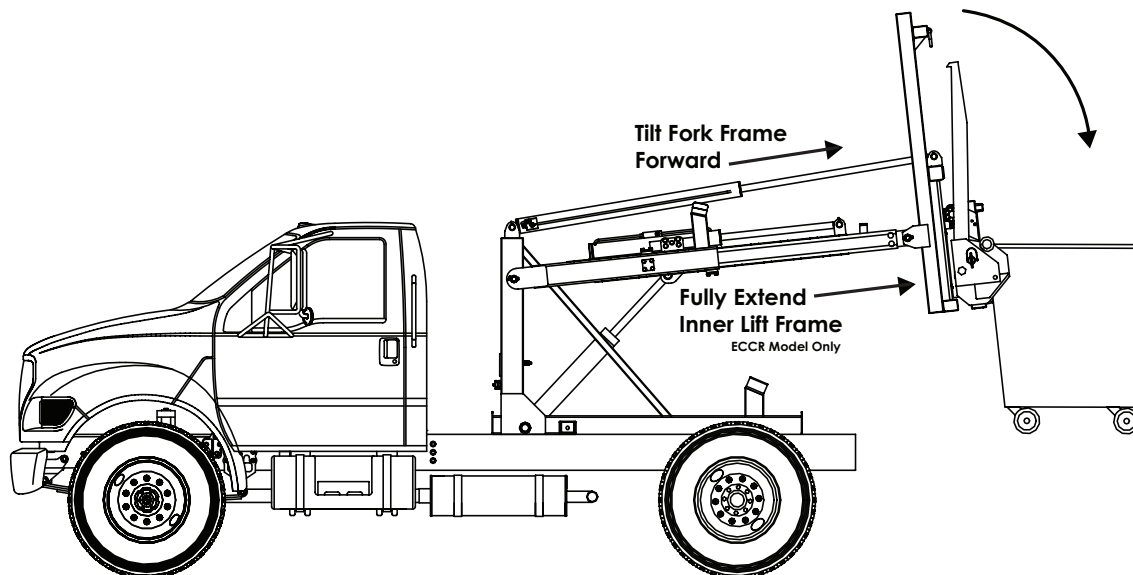

2. Tilt the fork frame forward and fully extend the inner lift frame (ECCR Model Only).

# Placing a Rear Load Container

## Step 3

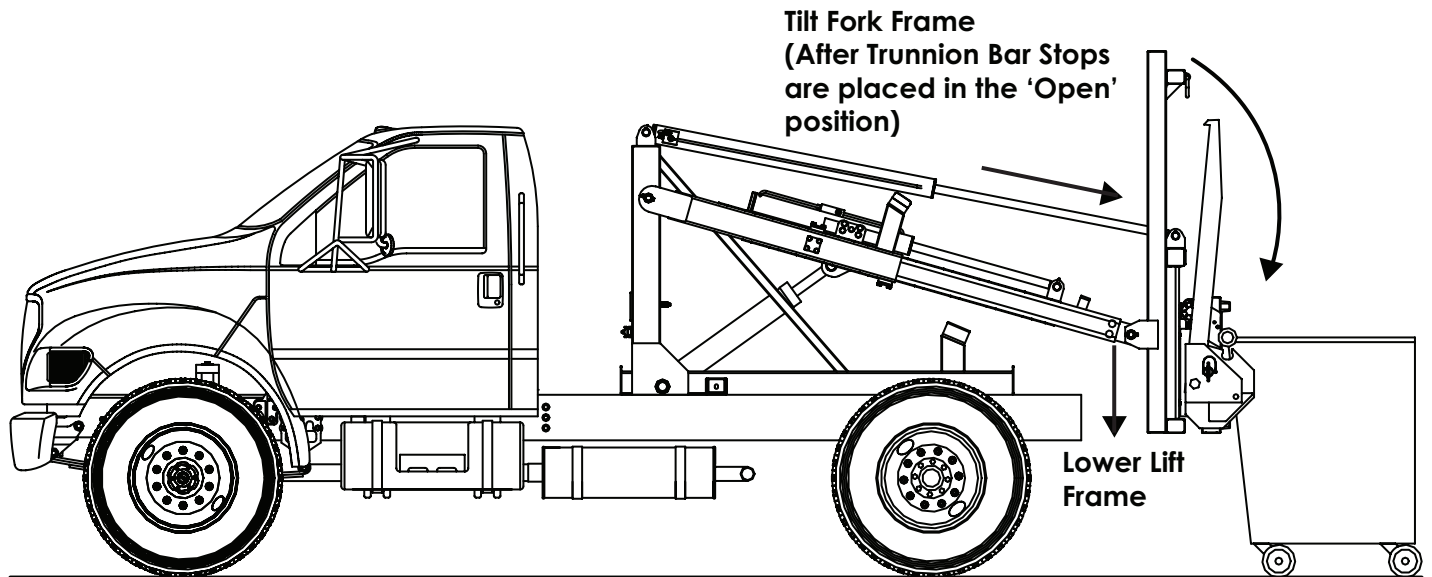

3. Lower the lift frame until the container is fully rested on the ground. Set the trunnion bar stops to the open position. Tilt the fork frame down enough to clear the trunnion bar slots.

## Step 4

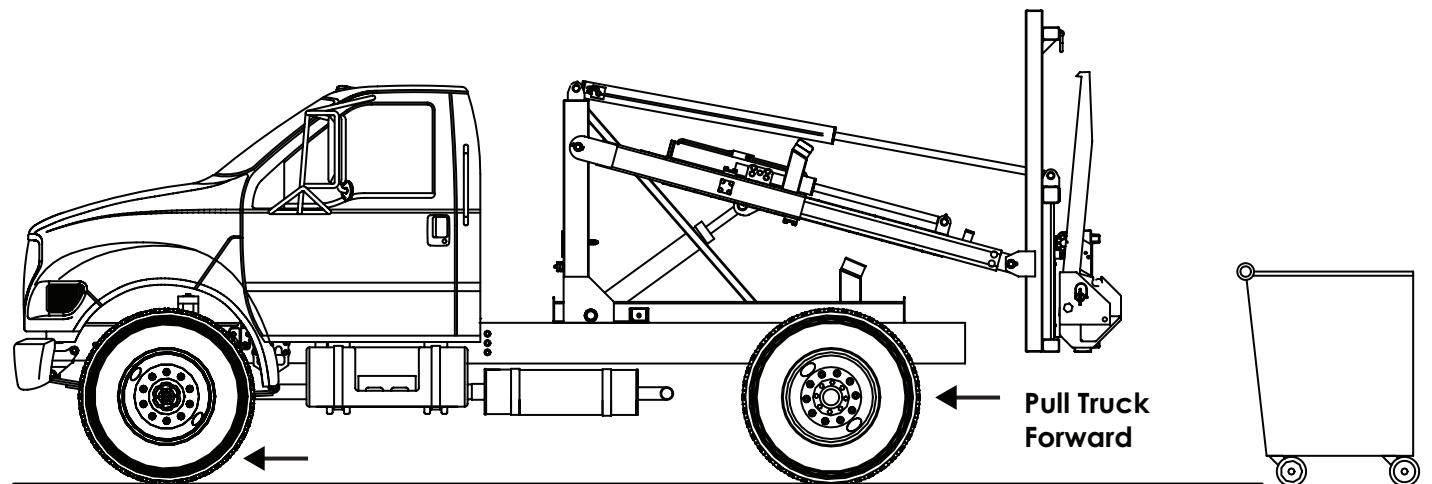

4. Slowly pull the truck forward until the trunnion bar slots are clear of the container.

# Placing a Rear Load Container

## Step 5

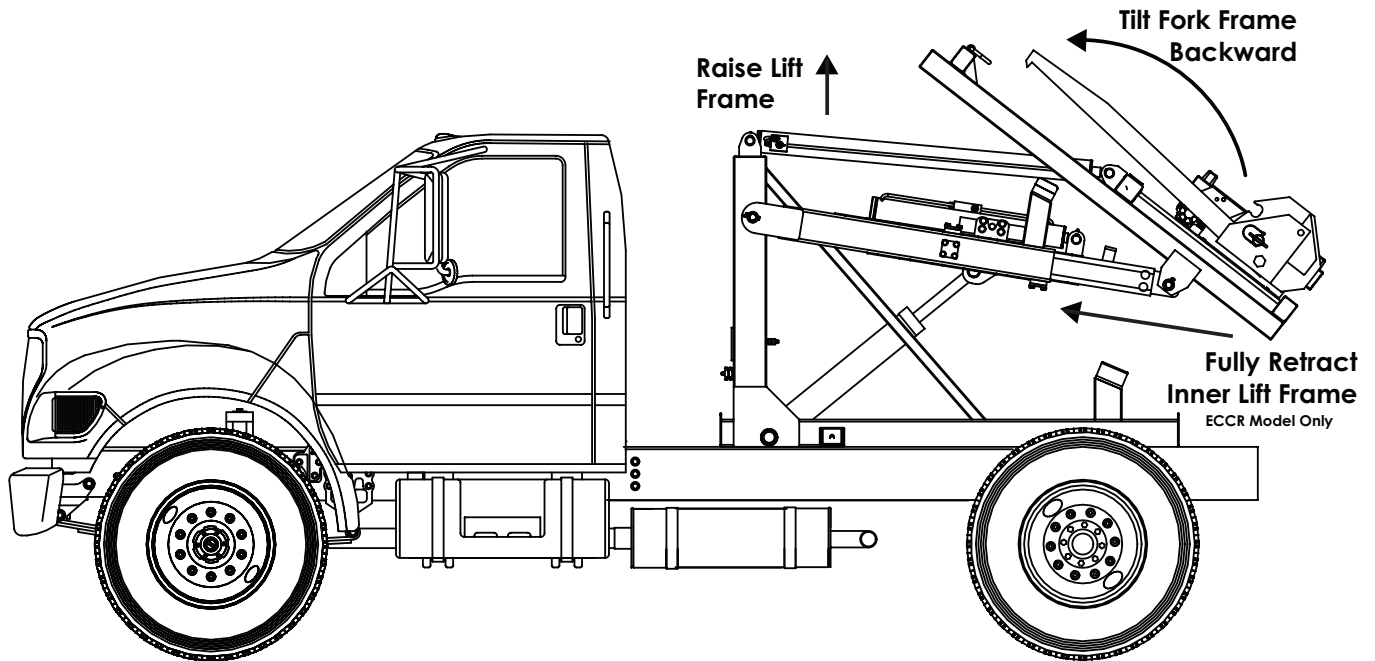

5. Raise the lift frame high enough to clear the truck frame. Fully retract the inner lift frame (ECCR Model Only). Tilt the fork frame all the way up so full contact is made with the rest pads.

## Step 6

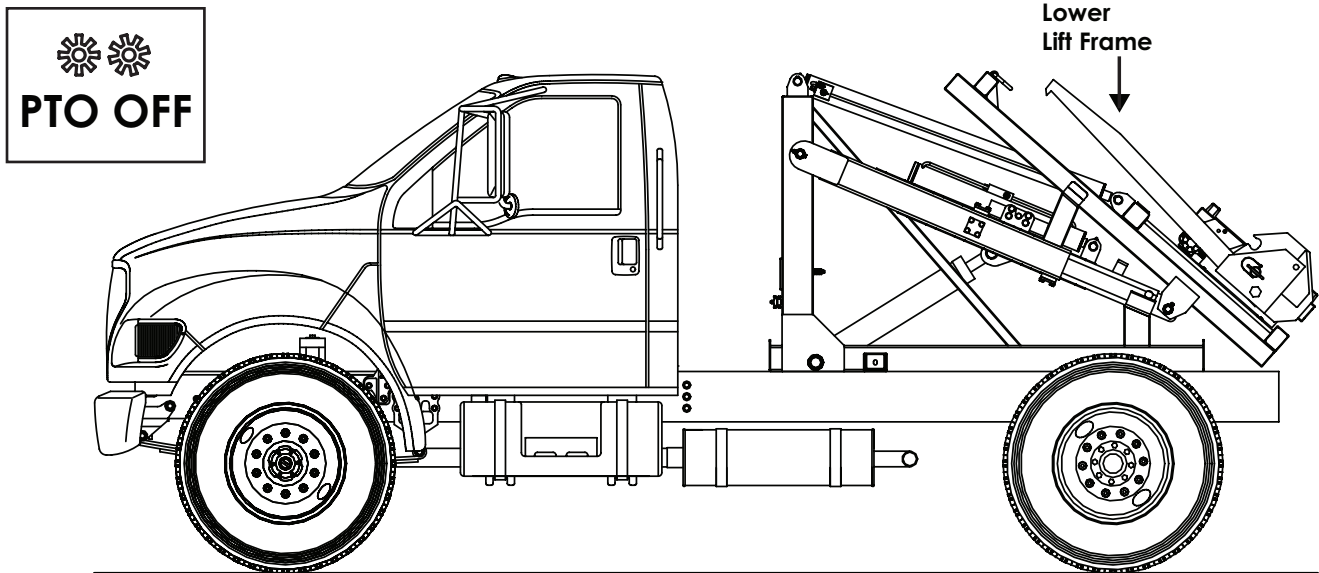

6. Lower the lift frame completely and disengage the PTO.

# Lifting a Large Rear Load Container

## Step 1

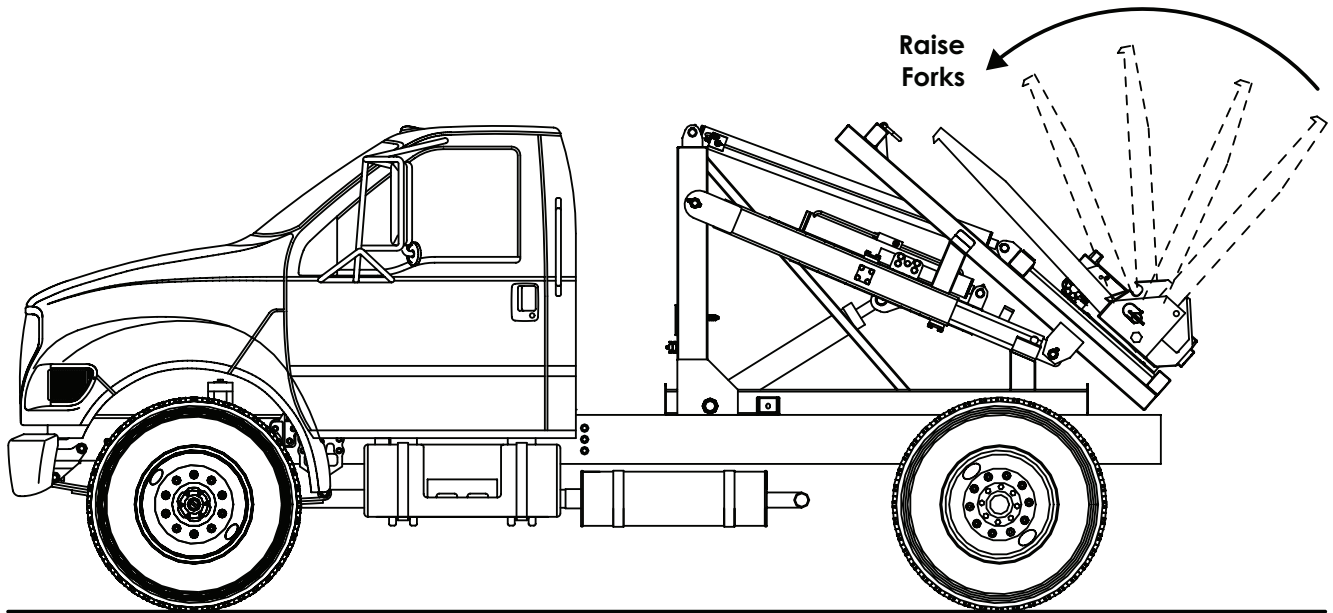

1. If the forks are in the extended position, manually rotate them to the stored position. Lock the forks into place with the fork stop pins.

**⚠ WARNING** Be sure that the area in which the container carrier is to be operated is clear of personnel and obstacles overhead and on the ground.

## Step 2

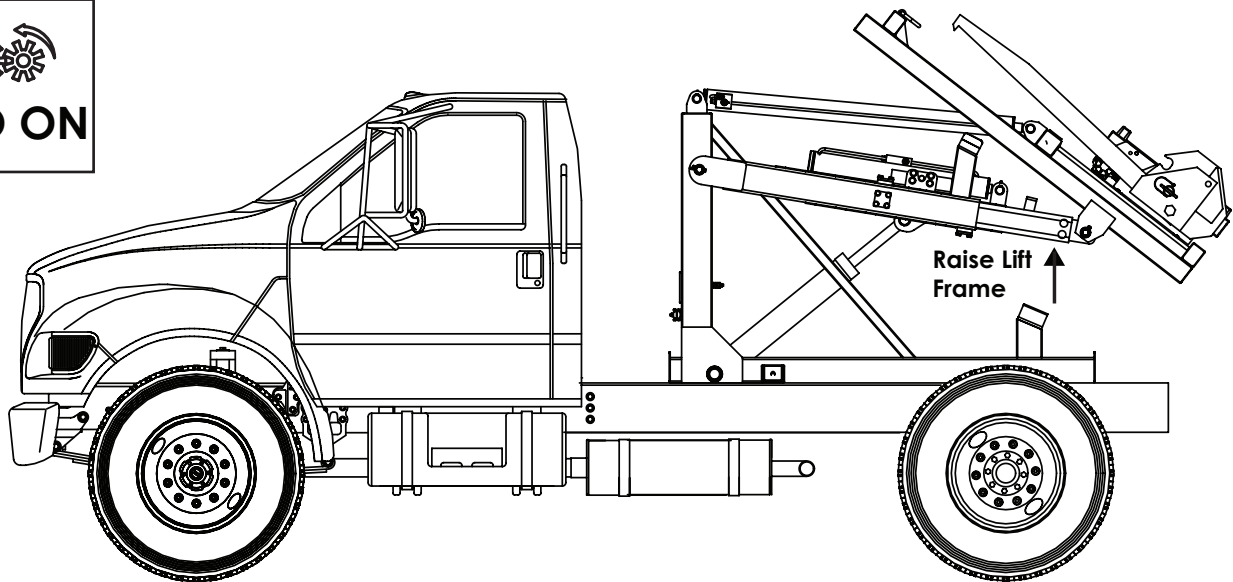

2. Engage the PTO and raise the lift frame high enough to clear the truck frame.

# Lifting a Large Rear Load Container

## Step 3

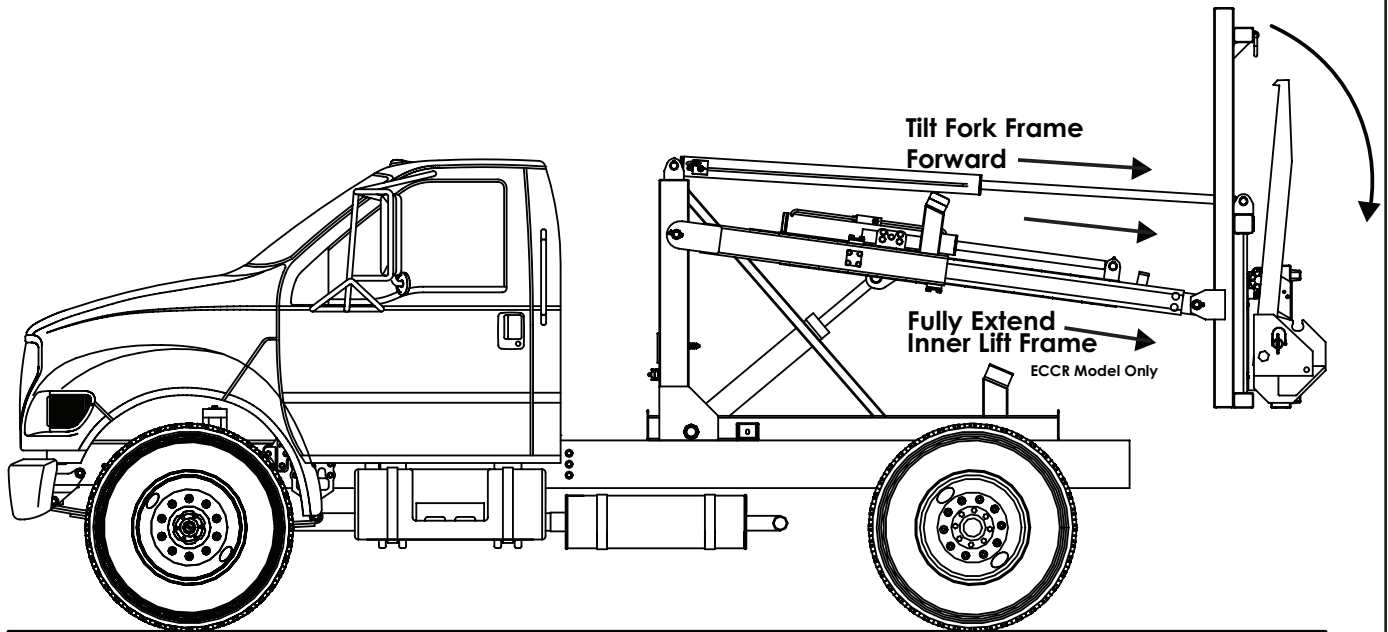

3. Tilt the fork frame forward and fully extend the inner lift frame (ECCR Model Only).

## Step 4

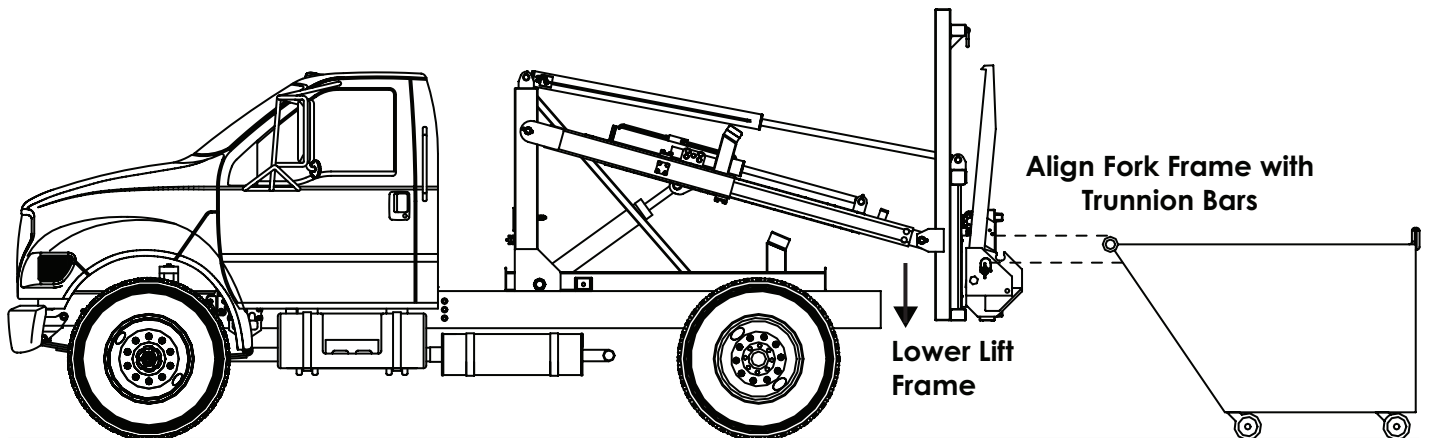

4. Align the fork frame with the trunnion bar on the container by lowering the lift frame and tilting the fork frame.



# Lifting a Large Rear Load Container

## Step 5

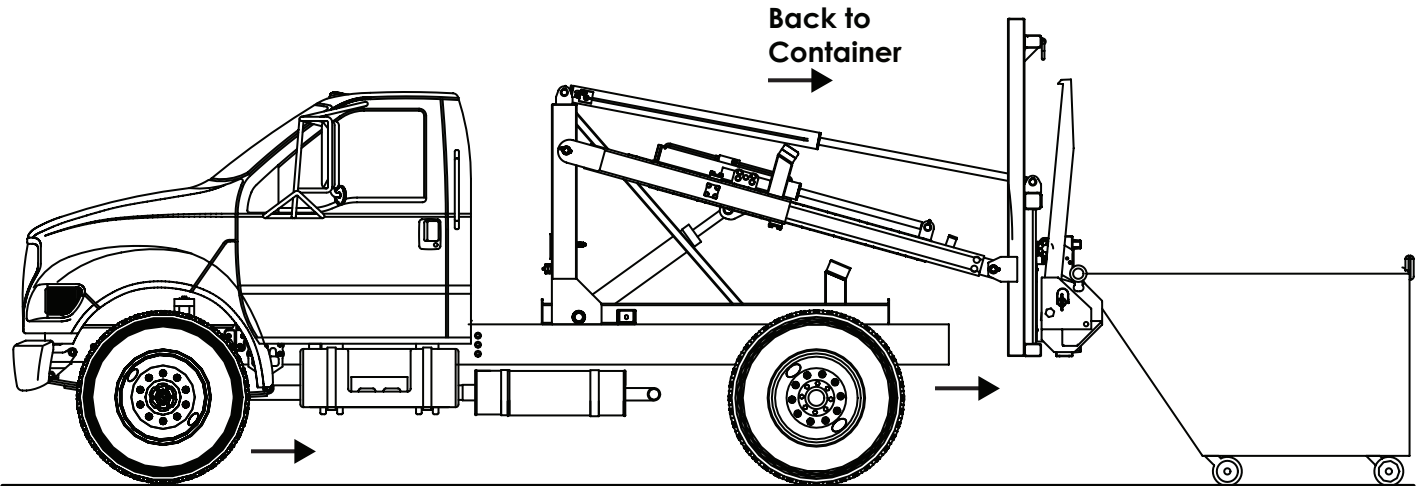

5. Slowly back the truck up to the container.

## Step 6

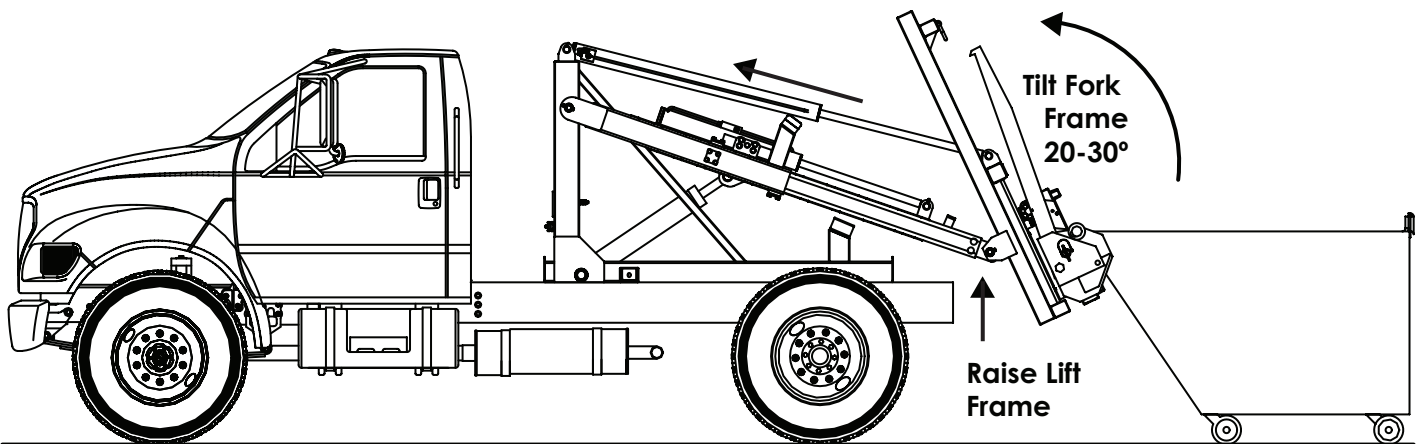

6. Raise the lift frame until the trunnion bars are securely located in the slots. Tilt the fork frame up approximately 20 to 30 degrees. Put both trunnion bar stops in the 'locked' position (See next page).

# Lifting a Large Rear Load Container

Note: Trunnion Bar Stops

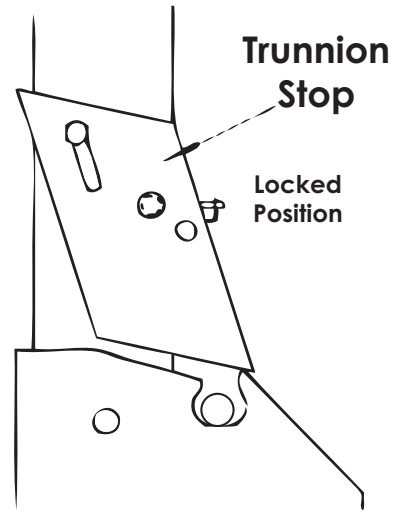
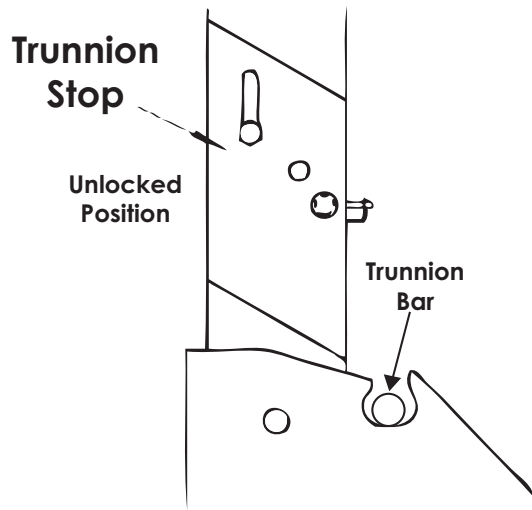

## Step 7

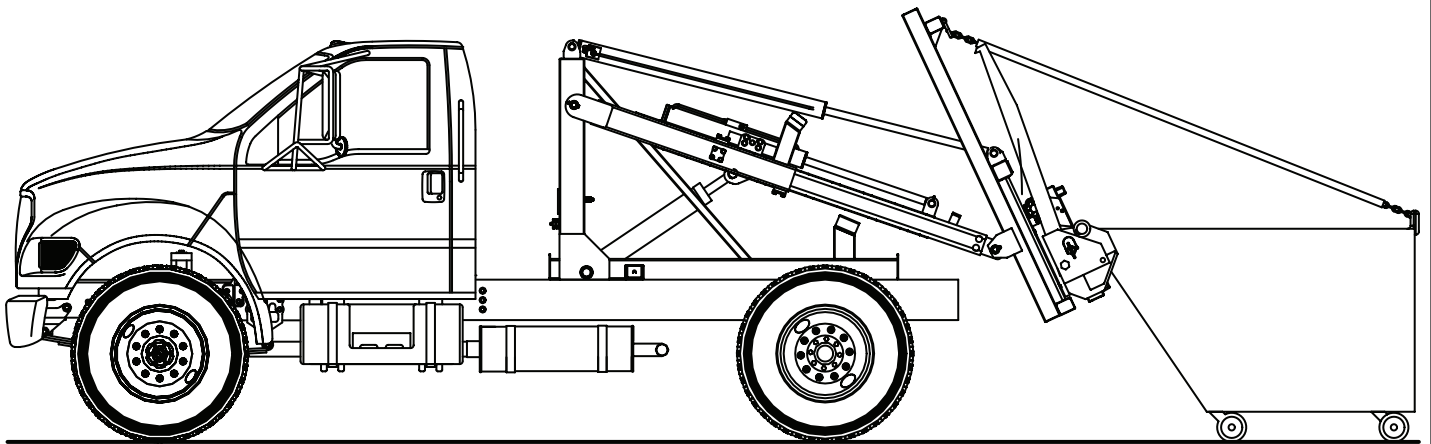

7. Attach a chain from the top of the fork frame to the container. Run the chain through a pipe to prevent the container from tipping forward if the truck has to make a sudden stop.

# Lifting a Large Rear Load Container

## Step 8

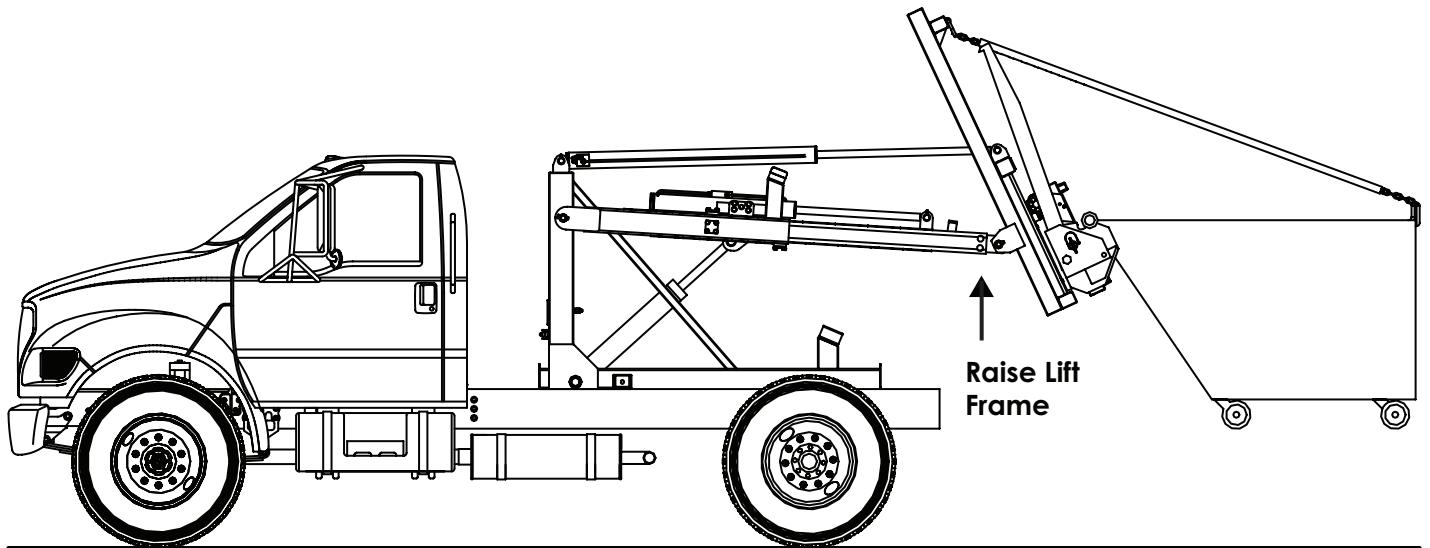

8. Raise the lift frame high enough to clear the truck frame

## Step 9

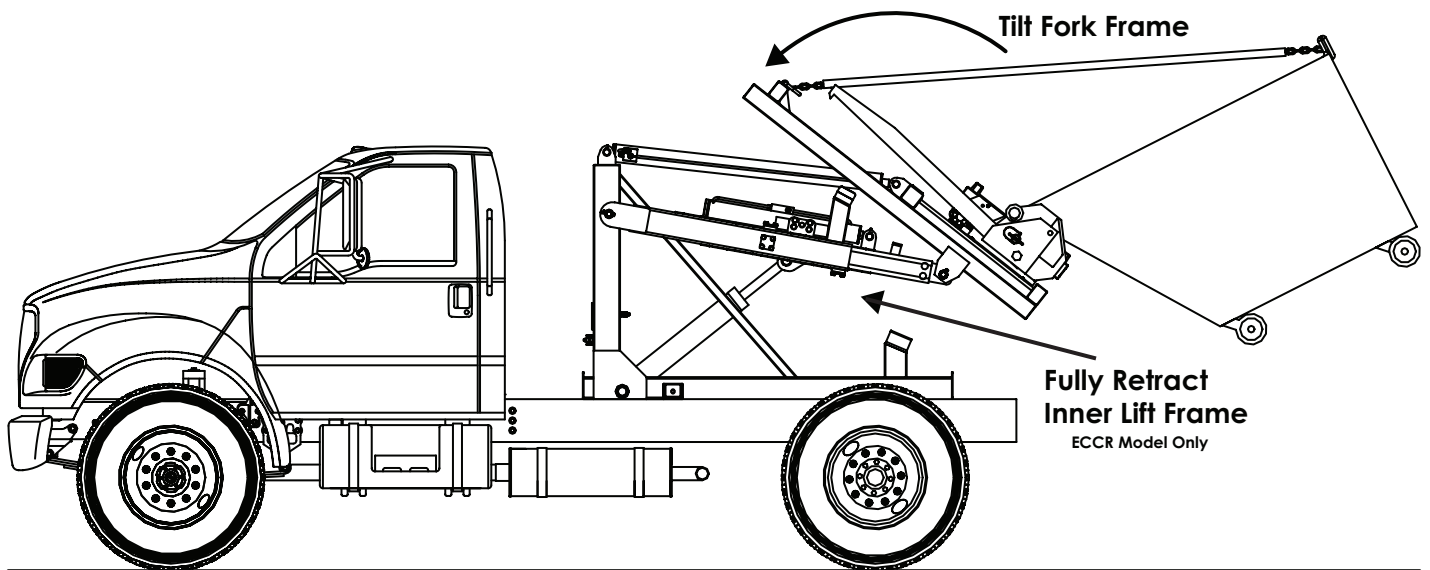

9. Tilt the fork frame all the way up so full contact is made with the rest pads. Fully retract the inner lift frame (ECCR Model Only).

# Lifting a Large Rear Load Container

## Step 10

  
**PTO OFF**

Lower  
Lift Frame

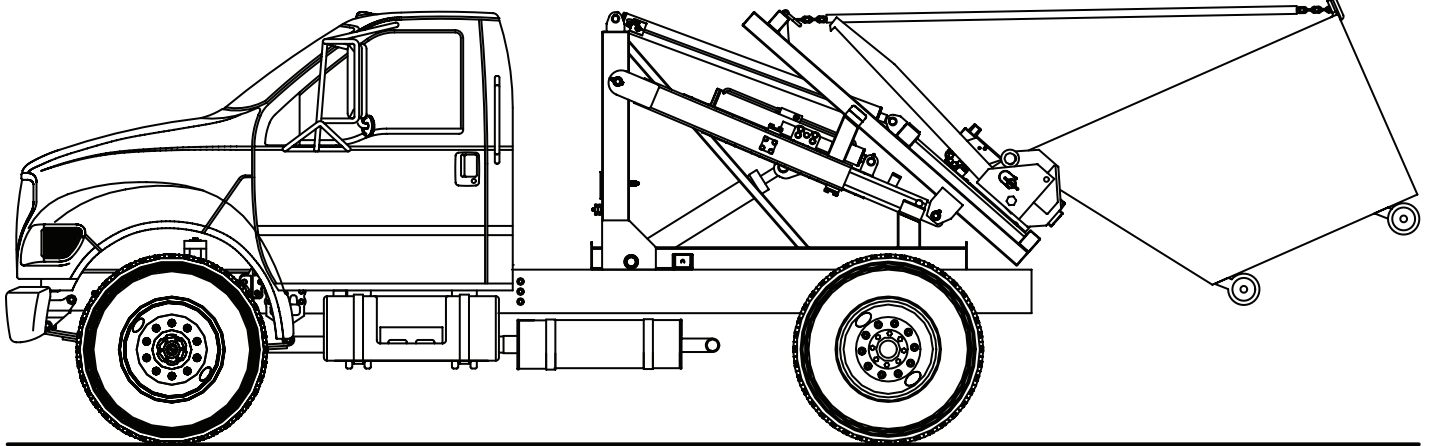

10. Lower the lift frame completely and disengage the PTO. Note: Check local DOT lighting regulations before transporting.

# Operation of Rotator

## Important Notes:

### **Do not use rotator with rear load container.**

Do not lift a container heavier than 8,000 lbs. max

Do not rotate fork carriage with forks in stored position. Possible damage to fork carriage may result.

### **Directions**

1. Tilt forks up approximately 15° before rotating the container.
2. Slowly rotate fork carriage to empty container.

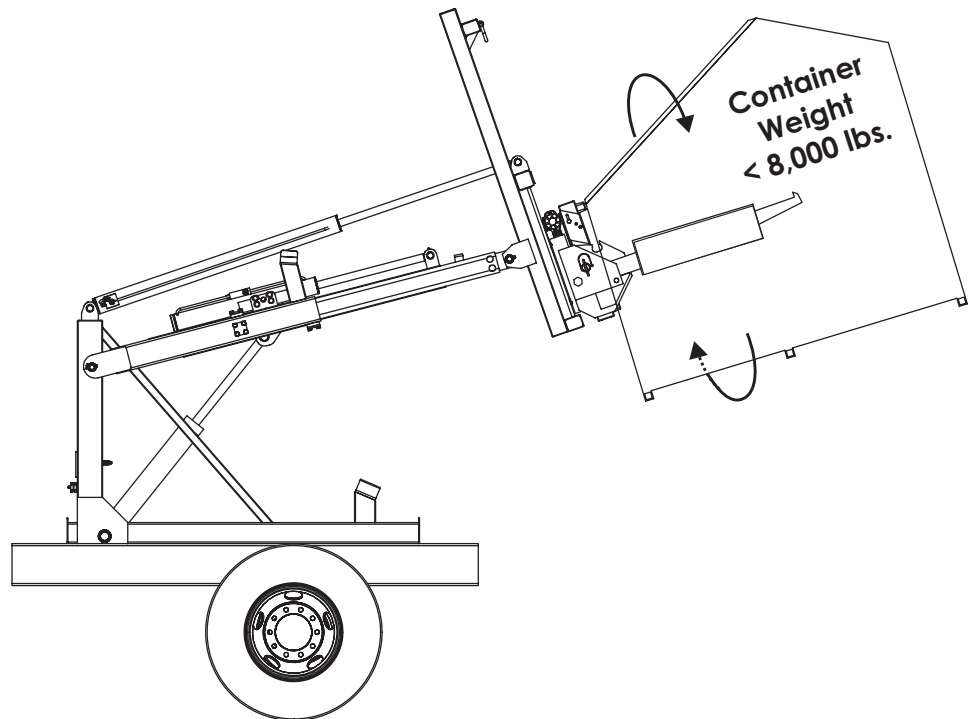

**⚠ WARNING** Failure to tilt forks up before rotating container may result in container sliding off of forks with possible damage to equipment and injury to personnel



# Chapter 2 - Maintenance

Maintenance is an important part of extending the life of any Stellar® Container Carrier. Performing key maintenance items on a scheduled program will prevent unnecessary downtime.

## Basic Container Carrier Inspection Schedule

At the proper interval, inspect the following items:	Daily	Monthly
Hydraulic reservoir oil level	X	
Hydraulic hoses and tubing for evidence of damage such as blistering, crushing, or abrasion	X	
All safety covers for proper installation	X	
Equipment for missing, illegible, or defaced operating decals and safety signs	X	
Structural weldments for bends, cracks, or breaks	X	
All pins and keepers for proper installation	X	
Presence of this owner's manual	X	
All pins, bushings, shafts, and gears for wear, cracks, or distortion to include all pivot points, and bushings	X	
Parking brake operation	X	
Cylinder movement due to leakage		X
Controls for malfunction or adjustment		X
Hydraulic systems for proper operating pressure		X
Cylinders for damaged rods, dented barrels, drift from oil leaking internally, leaks at rod seals or holding valve.		X
PTO and pump for leaks		X
Jib assembly for excessive side-to-side play or chattering.		X
Frame bolt tightness - turn barrel nuts and mounting bolts during the first month of operation on new machines and then quarterly thereafter		X
Inspect all electrical wires and connections for worn, cut, or deteriorated insulation and bare wire		X
Lubrication of all moving parts		X

# General Maintenance Guidelines

Before performing any maintenance to the container carrier, consider the following:

- **⚠️ WARNING** Only qualified service personnel are to perform maintenance on the container carrier. Never modify or alter any of the equipment, whether mechanical, electrical, or hydraulic, without explicit approval from Stellar Industries.
- Position the container carrier where it will be out of the way of other operations or vehicles in the area.
- Make certain that the container carrier is in the fully stowed position to prevent uncontrolled movement.
- Place all controls in the off position and secure operating features from inadvertent motion. Follow company specific lock-out/tag-out procedures.
- When checking hydraulic oil level, make certain that **all system cylinders** are fully retracted.
- Grease zerk locations can be found in the *Installation, Assembly Drawings, Parts Manual*.
- Before any service or repair is performed, disengage the PTO and shut off the engine.
- Before performing any maintenance on electrical components, disconnect the power source.
- Before performing any maintenance on hydraulic components, relieve hydraulic oil pressure from all hydraulic circuits. Move control levers repeatedly through their operating positions to relieve all pressures.
- **⚠️ WARNING** Do not disconnect hydraulic hoses while there is still pressure in those components.
- **⚠️ WARNING** Do not touch or grab any hoses that could be under pressure.
- Replace parts with Stellar® approved parts only.
- Keep the container carrier clean and free from grease build-up, oil and dirt to prevent slippery conditions.
- Label or tag parts when disassembling.
- Immediately repair or have repaired any components found to be inadequate.

## Hydraulic Oil/Filter Maintenance

Stellar Industries recommends the first filter change to occur after the first 250 hours of service. The second, and every subsequent change, should occur after every 1,000 hours of service. By following these guidelines, the hydraulic oil should last up to 6,500 hours. *Note: These recommendations are based on normal working parameters. If operating in less than favorable conditions excessive dust, moisture, etc.), be sure to check the filter gauge often for filter change notice.*



# PTO and Pump Maintenance

Every six (6) months, remove the hydraulic pump from the PTO and lubricate the splines using Chelsea Lubricant #379831 or Stellar PN 42042 (packet) or PN 20885 (lube). Failure to lubricate shaft splines will cause damage to the PTO and Hydraulic pump.

# Model CC and CCR Grease Locations

The pivot points on the Stellar® Container Carrier will need to be greased monthly to prevent the bushings from wearing out. Grease more frequently if the carrier is used 7 days a week. See chart later in this chapter for recommended greases to use.

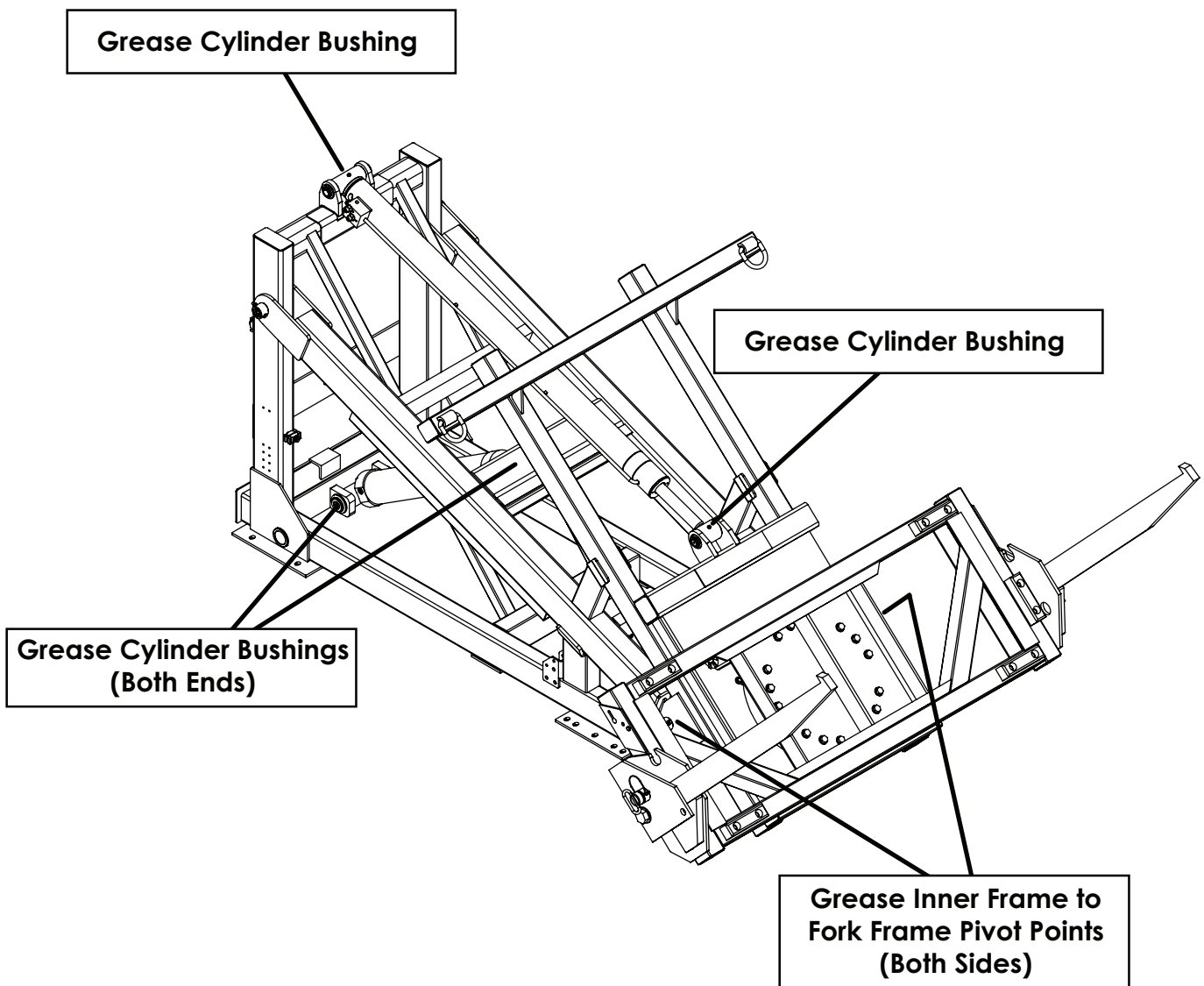

# Model ECCR Grease Locations

The pivot points on the Stellar® Container Carriers will need to be greased monthly to prevent the bushings from wearing out. Grease more frequently if the carrier is used 7 days a week. See chart later in this chapter for recommended greases to use.

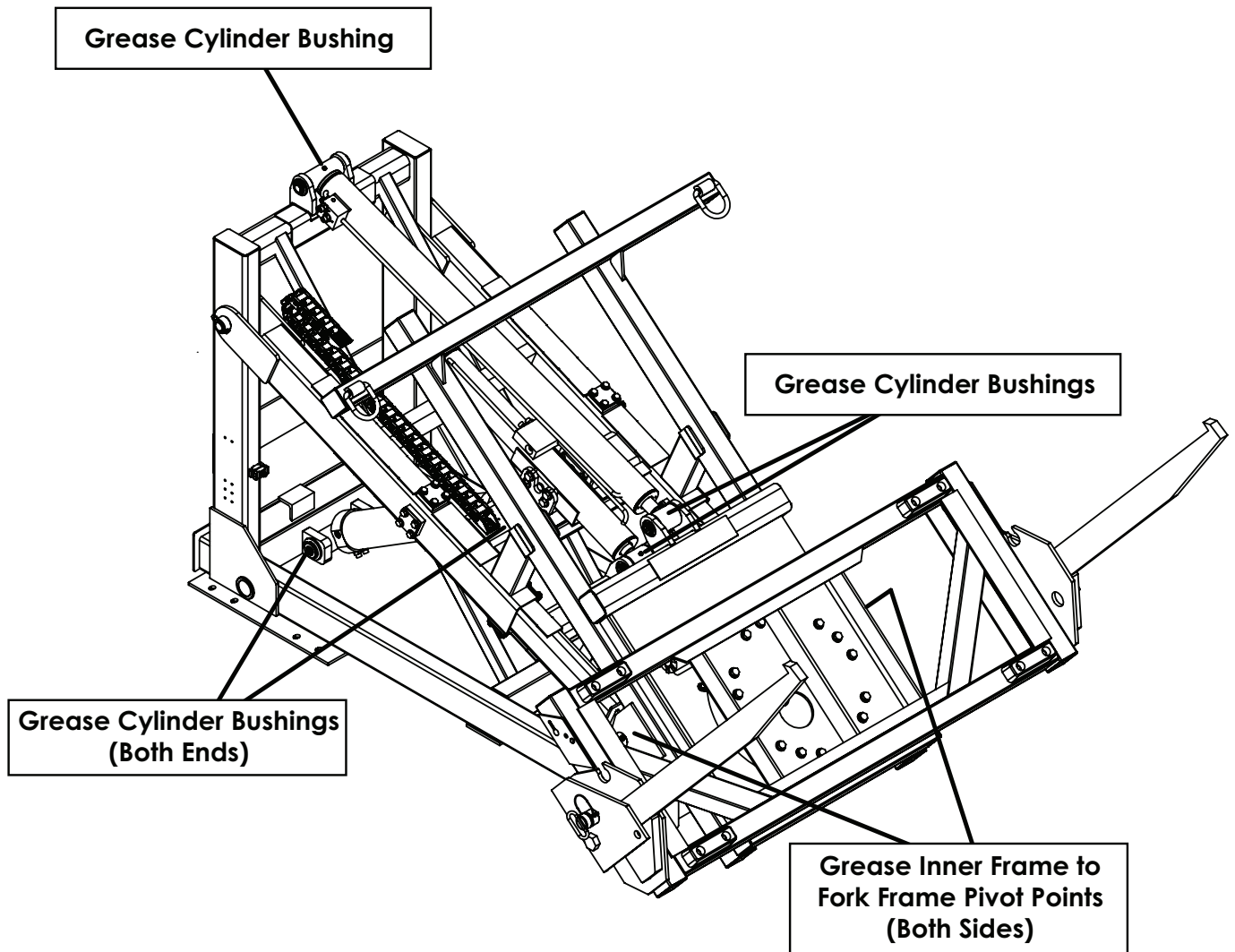

# CCR & ECCR Gear Bearing Grease

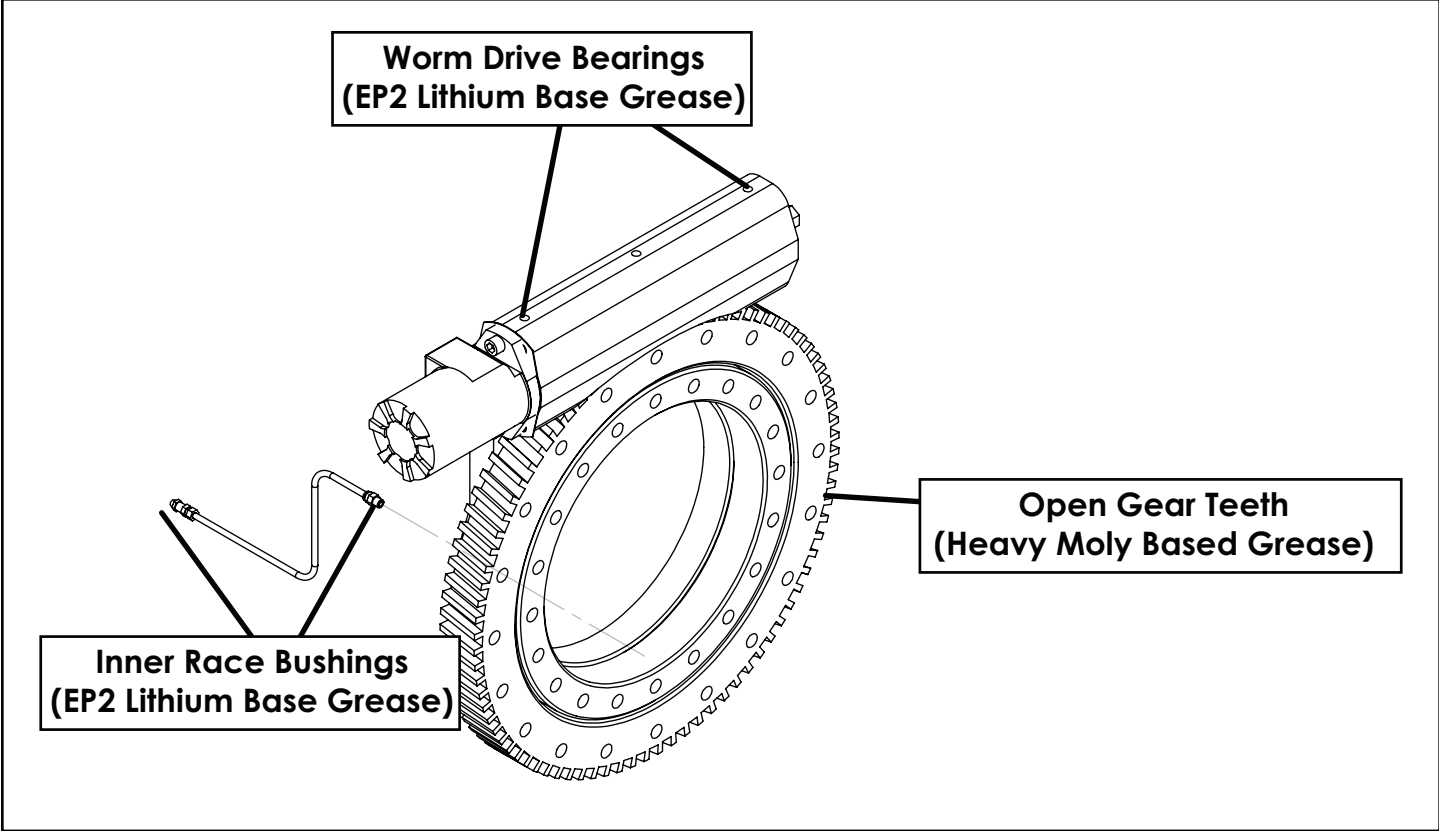

# Choice Lubricants for DX Bearings

## Greases Recommended

Type of Grease	Description
Premium Quality	Stabilized, Anti-Oxidant Lithium Base, Lithium Base with 3% Molybdenum Disulfide, High Drop Point
Multi-Purpose	Calcium Based, for General Automotive and Industrial Use, Calcium Grease, Water Stabilized, High Drop Point
Anti-Friction Bearing	Calcium Based with EP Additives, Lithium Based, Sodium Based
Extreme Pressure (EP)	Lithium Based with EP Additives, Calcium Based with EP Additives
High Temperature	Modified Sodium Based, High Drop Point
Transmission	Semi-Fluid, Calcium Based
Molybdenum Filled	Lithium Based with 2% Molybdenum Disulfide
Graphite Filled	Sodium Based with 2% Graphite
Block Grease	Sodium Based Solid Grease
White Grease	Aluminum Complex Based with Anti-Oxidant & Rust, Inhibitors & Zinc Oxide Additives
Silicone	Lithium Based with Silicone Oil Lubricant
Aerosol Lubricant	Silicone-based Lubricant

## Greases Not Recommended

Type of Grease	Description
Cup Grease	Light Service Calcium or Sodium Based Grease
Graphite Filled	Greases with More than 10% Graphite
Molybdenum Filled	Greases with More than 10% Molybdenum Disulfide
Fluorocarbon	Low Molecular Weight Chlorofluoroethylene Polymer with Inert Thickeners
White Grease	Calcium Based, Zinc Oxide Filled





Subject to Change without Notification.  
© 2018 Stellar Industries, Inc.