

AUGER COMPACTORS

AST SERIES

Stationary Auger Compactors



AST-440
Twin-Auger

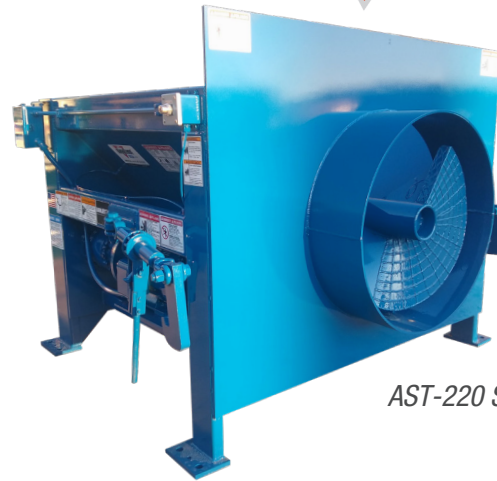

AST-220 Single Auger



Auger Compactor Features

- ▼ *Increased payloads can reduce transportation costs by up to 50% when compared to other applications*
- ▼ *Minimize waste storage space on site*
- ▼ *There are no cavities behind the auger mechanism where waste can accumulate*
- ▼ *Easy to use and maintenance friendly*
- ▼ *Always moves material forward*
- ▼ *The short distance behind the charge chamber, combined with a shorter deck height, makes the AST-220 and AST-440 ideal for dock applications*
- ▼ *Whisper-quiet operation*
- ▼ *Eliminates all hydraulic oil*



AST-320 Single-Auger

The Worldwide Compaction Leader

Marathon® Equipment is known throughout the world as one of the leading manufacturers of quality on-site waste compaction products. The RamJet® brand has been the industry standard for quality and innovation for more than 50 years, and includes stationary and self-contained compactors, compaction containers, apartment and high-rise compactors, pre-crushers, auger-style compactors, transfer systems, and a wide array of options for virtually any application.



Environmental
Solutions Group®

a DOVER company

AST-220

Single-Auger Stationary Compactor

AST-220 Features

- ▼ Easy to use and maintenance-friendly
- ▼ Always moves material forward
- ▼ Higher payloads on materials such as OCC
- ▼ Low deck height is better adapted for dock installations
- ▼ Whisper-quiet operation
- ▼ Eliminates all hydraulic oil
- ▼ Heavy-duty construction allows for the processing of tough materials such as skids and pallets



AST-220
Single-Auger

AST-220 Benefits & Specifications

Marathon® AST-220 Auger Compactors are easy to use and maintenance-friendly. They have no hydraulics and fewer moving parts than conventional compactors. The auger delivers superior compaction, which results in fewer container pulls, and reduced facility traffic. The round opening holds material, which means less separation spillage than a conventional compactor. The AST-220 auger can be installed directly at a dock door, eliminating the need to go outside, resulting in labor and forklift savings, increased productivity, and employee efficiency. This durable, high-performance auger will provide years of dependable performance.

AST-220 Specifications

Clear-Top Opening (L x W)	51" x 66 7/8"	1295mm x 1699mm
Weight	4,250 lbs.	1928 kg
Auger Diameter	36"	900mm
Auger Penetration	11"	265mm

Performance Characteristics

Auger Speed	14 rpm
Cycle Time	8.5 seconds

Electrical Equipment

Electric Motor 3/60/230-460	20 hp	15kW
------------------------------------	-------	------

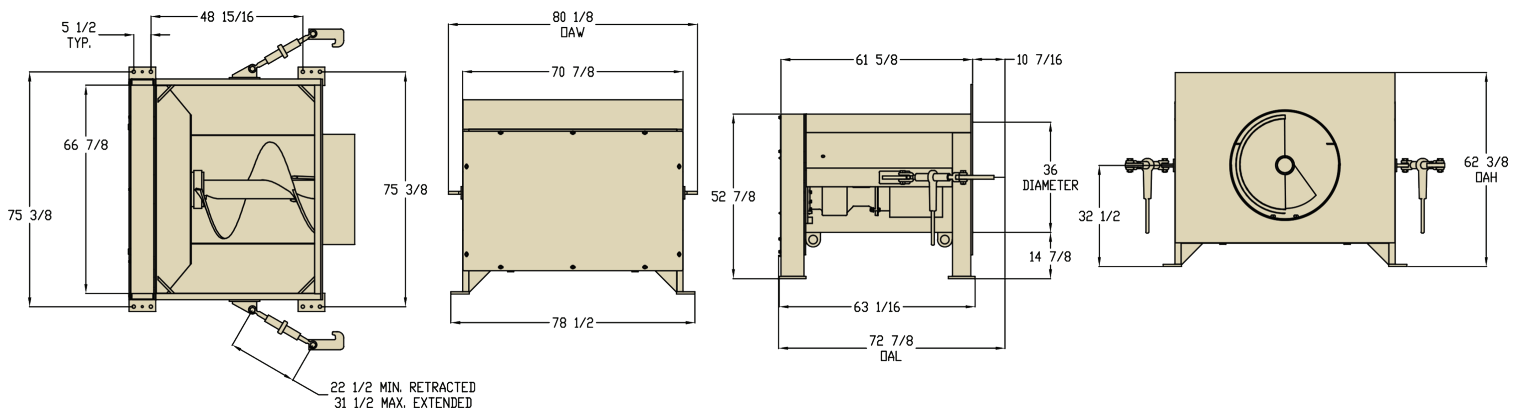

Pictures and mechanical diagrams in this literature are illustrative only and may not be to scale. Specifications are subject to change without notice in order to accommodate improvements to the equipment. Certified in compliance with ANSI standard Z245.2, all applicable OSHA Regulations. Products must be used only by trained operators in accordance with the Operator Manual, as well as applicable regulations, laws, and ANSI standards.

AST-320

Single-Auger Stationary Compactor

AST-320 Features

- ▼ Easy to use and maintenance-friendly
- ▼ Always moves material forward
- ▼ Whisper-quiet operation
- ▼ Eliminates all hydraulic oil
- ▼ Materials will not build up behind the auger
- ▼ Heavy-duty construction allows for the processing of materials such as skids and pallets



AST-320
Single-Auger

AST-320 Benefits & Specifications

Marathon® AST-320 Auger Compactors are easy to use and maintenance-friendly. They have no hydraulics and fewer moving parts than conventional compactors. The auger delivers superior compaction, resulting in fewer container pulls and reduced facility traffic. The round opening holds material, reducing separation spillage when compared to a conventional compactor. The AST-320 auger can be installed directly at a dock door, eliminating the need to go outside, which results in labor and forklift savings, increased productivity, and employee efficiency. This durable, high-performance auger will provide years of dependable performance.

AST-320 Specifications

Clear-Top Opening (L x W)	68 1/2" x 72 3/4"	1740mm x 1848mm
Weight	6,950 lbs.	3152 kg
Auger Diameter	48"	1219mm
Auger Penetration	11"	265mm

Performance Characteristics

Auger Speed	10 rpm
Cycle Time	13 seconds

Electrical Equipment

Electric Motor 3/60/230-460	20 hp	15kW
------------------------------------	-------	------

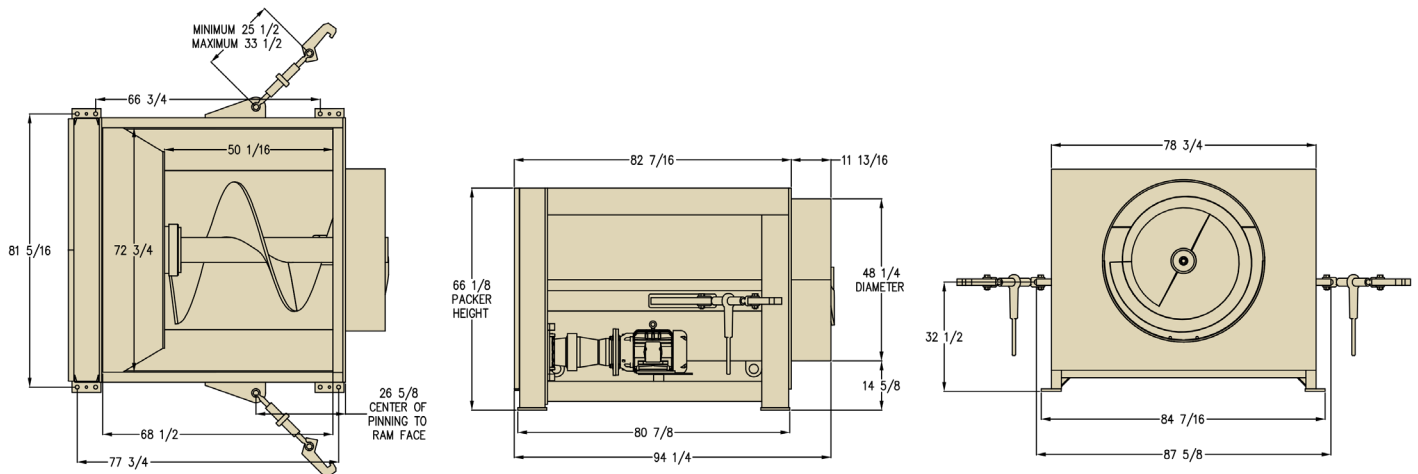

Pictures and mechanical diagrams in this literature are illustrative only and may not be to scale. Specifications are subject to change without notice in order to accommodate improvements to the equipment. Certified in compliance with ANSI standard Z245.2, all applicable OSHA Regulations. Products must be used only by trained operators in accordance with the Operator Manual, as well as applicable regulations, laws, and ANSI standards.

AST-440

Twin-Auger Stationary Compactor

AST-440 Features

- ▼ Easy to use and maintenance-friendly
- ▼ Always moves material forward
- ▼ Higher payloads on materials such as OCC, wooden pallets/crates, and other dry waste
- ▼ Ideal for volume reduction of bulky items such as wooden furniture
- ▼ Whisper-quiet operation
- ▼ Eliminates all hydraulic oil
- ▼ Heavy-duty construction allows for the processing of materials such as skids and pallets



AST-440
Twin-Auger

AST-440 Benefits & Specifications

The AST-440 Twin-Auger Compactor is a heavy-duty machine specifically designed for compacting large volumes of waste material. As a Stationary Compactor, the machine is best suited for dry waste such as paper, cardboard, wooden pallets, etc. The twin 28" Auger has excellent throughput, and is able to process large bulky items without bridging in the hopper, making it ideal for large industrial sites and production lines.

AST-440 Specifications

Clear-Top Opening (L x W)	75 15/16" x 83 13/16"	1929mm x 2129mm
Weight	9,500 lbs.	4309 kg
Auger Diameter	2 x 28"	2 x 700mm
Auger Penetration	16"	400mm
Performance Characteristics		
Auger Speed	10 rpm	
Cycle Time	12 seconds	
Electrical Equipment		
Electric Motor 3/60/230-460	2 x 20 hp	2 x 15kW

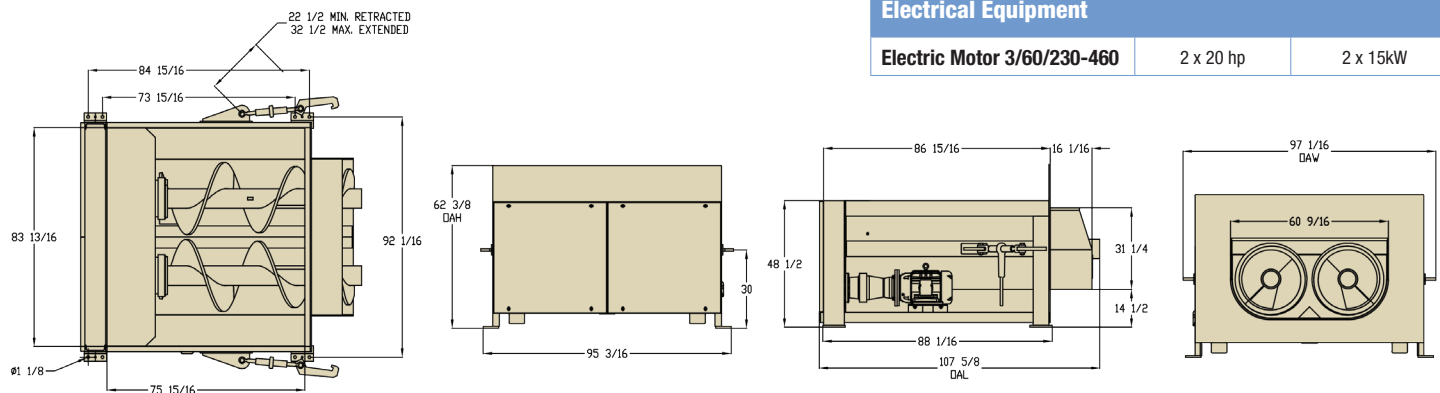

Pictures and mechanical diagrams in this literature are illustrative only and may not be to scale. Specifications are subject to change without notice in order to accommodate improvements to the equipment. Certified in compliance with ANSI standard Z245.2, all applicable OSHA Regulations. Products must be used only by trained operators in accordance with the Operator Manual, as well as applicable regulations, laws, and ANSI standards.



Connected Collections™

1 BACK-OF-STORE CONNECTED ASSET SOLUTIONS



1 Focus on the front of the store, we've got the back.

The ultimate solution for peace of mind, efficiency, and productivity.

2 Marathon® provides a full suite of value-added needs.

New and Marathon Certified Remanufactured compactors and balers, digital connectivity, and waste stream monitoring to minimize your waste-related expenses and maximize recycling revenue.

3 Digital connectivity enables asset monitoring, assists with predictive maintenance, and connection to hauler operations.

Partnership with Marathon® supports your long-term sustainability objectives - and provides documentary evidence of your performance.

3 All the information you need at the tips of your fingers.

Eye-Site™ provides a complete dashboard view of the waste and recycling programs for your entire enterprise.

BEST BRAND. UNMATCHED CUSTOMER VALUE. ALL EYES ON YOUR BUSINESS.

Asset Management

- Availability and predictability of assets
- Preventative Maintenance & Service Agreements
- Extended Warranty options
- OEM Parts
- Marathon Certified Remanufacturing with the same warranty as new

Waste Metering

- Right product in the right bucket
- Traceability and control of recycling material
- Enterprise tracking for sustainability goals and measurement
- Reduce contamination

Productivity

- Ensure you have the right equipment
- Pick up when full and not early. Minimize disposal costs
- Remote fullness monitoring & bale weight monitoring
- Maximize recycling revenue



- Self-Contained Compactors
- TC Tanks
- Stationary Compactors
- Auger Compactors
- Containers & Carts
- VIP
- MPT
- Mini-Mac
- VB
- Cart Dumpers

MARATHON WARRANTY

Marathon® Equipment is pleased to announce the release of our updated Warranty Coverage program. This warranty will take effect and be applicable on all products sold on or after June 1st, 2021. Note that this warranty plan is not retroactive to products sold prior to June 1st, 2021.

Marathon® Compaction Solutions Warranty

3 Yr. Structural, 2 Yr. Parts, 1 Yr. Labor

Our existing Signature Series Warranty, Compactor Warranty, and Auger Warranties have been combined into a new Compaction Solutions Warranty. The Compaction Solutions Warranty includes **3-years structural warranty, 2-years part warranty, and 1-year labor warranty.**

Worry-Free, Lowest Life-Cycle Cost

You have great options for equipment acquisition. Choose from a new Marathon® compactor or baler, or get a Marathon Certified Remanufactured product backed by the same best-in-industry warranty of a new Marathon product.

Our multiple extended warranty options, preventive service and maintenance programs, OEM parts, and asset connectivity all combine to optimize the performance of your equipment.

Digital connectivity monitors your assets ensuring predictive and condition-based equipment maintenance. Eliminate the costs associated with unnecessary down time and repairs. Service only when needed and replace only when and what is needed.

GOT CORES? **TRADE IN - TRADE UP!**

Through our **Marathon** Certified Remanufactured compactor and baler program, you can now establish a true closed-loop recycling process, which not only includes your commodities, but also your equipment.

The **Marathon** Certified Remanufacturing program allows you to purchase a factory-certified remanufactured product with the same warranty as a brand new one, providing a solution to optimize recycling commodities AND equipment.

For more information on the Marathon Cores Program, contact your local dealer.



AUGER COMPACTORS



Marathon® AST Auger Compactor Series

Summary

Perfect for:

-  Logistic Centers
-  Large Car Retail Centers
-  Large Volumes of Cardboard
-  Pallets/Skids
-  Residential/Commercial Remodeling Companies
-  Furniture Distribution Centers

Auger Compactor Series Model Comparison

Specifications	AST-220		AST-320		AST-440	
Clear-Top Opening (L x W)	51" x 66 7/8"	1295mm x 1699mm	68 1/2" x 72 3/4"	1740mm x 1848mm	75 15/16" x 83 13/16"	1929mm x 2129mm
Weight	4,250 lbs.	1928 kg	6,950 lbs.	3152 kg	9,500 lbs	4309 kg
Auger Diameter	36"	900mm	48"	1219mm	2 x 28"	2 x 700mm
Auger Penetration	11"	265mm	11"	265mm	16"	400mm
Performance Characteristics						
Auger Speed	14 rpm		10 rpm		10 rpm	
Electrical Equipment						
Electric Motor 3/60/230-460	20 hp	15kW	20 hp	15kW	2 x 20 hp	2 x 15kW

A pallet's worst nightmare.

The heavy-duty construction of **Marathon** auger compactors makes them the perfect choice for tough waste such as skids, pallets, and wooden crates. Quick processing and superior volume reduction can save both time and money.



Optional Round Opening Container Adapter

Marathon highly recommends using the optional Round Opening Container Adapter Plate. This option is quickly and easily added to a standard rectangular container opening, and helps to ensure clean container break-away with the least possible spillage of any stationary compactor.

We're Here To Help!

For detailed specifications, recommendations, or to request a site survey comparing various systems, contact the Marathon® Sales Team at MarathonSales@MarathonEquipment.com

Authorized Dealer:



Marathon Equipment Company | P.O. Box 1798 | Vernon, AL 35592-1798

Learn more about Marathon Equipment: 800.633.8974 | www.marathonequipment.com



www.marathonequipment.com

Contact your Marathon® authorized dealer: