

SELF-CONTAINED COMPACTORS

Pak'nTainer®

Self-Contained Compactor/Container



Pak'nTainer® Features

- ▼ Portable design for easy placement
- ▼ Front, rear, and through-the-wall loading options
- ▼ Economical self-contained compactor with remote power pack
- ▼ No anchoring required, suitable for concrete or asphalt surfaces
- ▼ Tapered container provides superior compaction ratios and aids in waste ejection
- ▼ Liquid-tight construction is perfect for wet waste, and ensures a sanitary environment



The Worldwide Compaction Leader

Marathon® Equipment is known throughout the world as one of the leading manufacturers of quality on-site waste compaction products. The RamJet® brand has been the industry standard for quality and innovation for more than 50 years, and includes stationary and self-contained compactors, compaction containers, apartment and high-rise compactors, pre-crushers, auger-style compactors, transfer systems, and a wide array of options for virtually any application.



Environmental
Solutions Group®

a DOVER company











SELF-CONTAINED COMPACTORS



Marathon® Pak'nTainer® (MPT)

Available in 5.5 Cubic-Yard Front-Load Model

Perfect for:

-  Supermarkets
-  Restaurants
-  Hospitals
-  Clinics
-  Nursing Homes
-  Shopping Centers
-  Airline Food Service
-  Malls
-  Schools
-  Convenience Stores

The Marathon® Pak'nTainer® is a portable and economical self-contained compactor/container with a remote power pack.

The **Pak'nTainer** is specially designed for compacting and containing wet or dry waste and simplifying waste dumping.

Its liquid-tight design helps maintain a sanitary environment, while saving money, for those generating as little as 20 cubic-yards of refuse a week.

Place the **Pak'nTainer** wherever needed, whenever needed — temporarily or permanently. No anchoring, no concrete pad, no special surfaces required. It can be used alone or to “fill the gap” in combination with other units.

The container is tapered to achieve superior compaction ratios and aid with waste ejection, which eliminates excessive wear and tear on collection trucks. It can also be chute-fed to allow the container to be placed in an area that is not aligned with a wall opening, similar to self-contained or stationary compactor applications.



Some images shown with optional equipment



For more information or to order, call 1-800-633-8974 or visit us at www.marathonequipment.com

SELF-CONTAINED COMPACTORS

Marathon® Pak'nTainer® (MPT)

Features & Benefits



Pak'nTainer® Features

- ▼ Large 48" x 22 9/16" clear-top opening handles even large, bulky items
- ▼ Cycon Life-Xtender™ Control System (for use with 3-phase only) reliable PLC controls eliminates the need for limit switches, dramatically improves cold-weather performance, and reduces maintenance costs and downtime
- ▼ Fixed breaker-bar teeth help keep materials in container and charge box clear
- ▼ Hydraulic plumbing to both sides with quick-release disconnects for added versatility in any application
- ▼ Tri-voltage standard for easy conversion to 208-, 230-, or 460-volt power
- ▼ Single-phase 110 with 3/4 hp motor available at no additional charge
- ▼ Heavy-duty hinges for durability
- ▼ Lockable panel box to increase security
- ▼ Convenient low loading height

Pak'nTainer® Optional Features

- ▼ Hopper enclosures
- ▼ Security chute
- ▼ 90-gallon cart dumpers
- ▼ Ozone generator



Cycon Life-Xtender™ Cyclic Control System

Standard on all **Marathon**
Pak'nTainer compactors.



Simple and durable latch assembly

*Easy-to-operate latch saves on
time and maintenance.*



Protection with optional hopper and lids

*Pak'nTainer with optional hopper
and plastic lids to keep contents
in, rain and the elements out.*

SELF-CONTAINED COMPACTORS



Marathon® Pak'nTainer® (MPT) Dimensions and Specifications

Specifications		
Total Capacity	5.5 yd ³	4.6 m ³
Compactor Capacity	0.49 yd ³	0.38 m ³
Clear-Top Opening	48" W x 22 9/16" L	1219mm x 573mm
Ram-Face Size	47 3/4" W x 19 3/4" H	501mm X 1212mm
Total Weight	2,791 lbs.	1,265 kg
Lift Weight	2,645 lbs.	1,199 kg
Performance Characteristics		
Cycle Time	28 seconds	
Force	19,800 lbs.	179 kN
Ram-Face Pressure	20.6 psi	212 kN
Ram Penetration	4"	193mm
Electrical & Hydraulic Equipment		
Electric Motor	3 hp	2.2 kW
Hydraulic Pump	3 gpm	11 L/min
Hydraulic Pressure	2,400 psi	166 bar
Cylinder Bore	2 1/2"	64mm
Cylinder Rod	1 1/4"	32mm
Cylinder Shaft	18 1/2"	470mm
Reservoir	5 gallons	19 liters

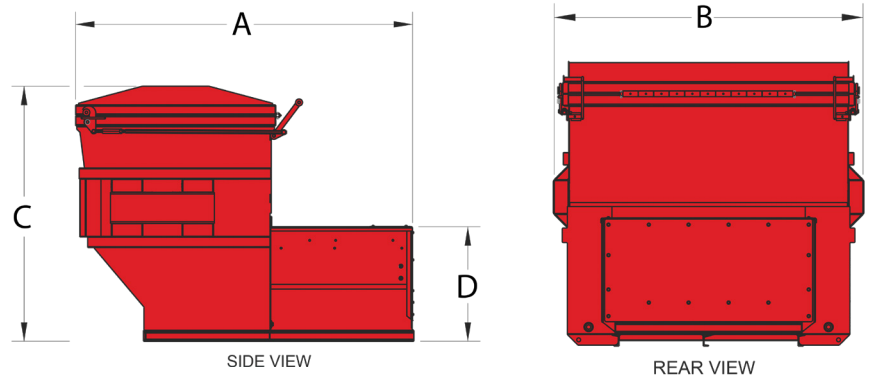

Pak'nTainer® DIMENSIONS	A	B	C	D	Weight
MPT-5.5 FL	97 9/16"	80 1/4"	73 9/16"	33 1/16"	2,645 lbs.
	2478mm	2038mm	1868mm	840mm	1,265 kg

Pictures and mechanical diagrams in this literature are illustrative only and may not be to scale. Specifications are subject to change without notice in order to accommodate improvements to the equipment. Certified in compliance with ANSI standard Z245.2, all applicable OSHA Regulations. Products must be used only by trained operators in accordance with the Operator Manual, as well as applicable regulations, laws, and ANSI standards.

We're Here To Help!

For detailed specifications, recommendations, or to request a site survey comparing various systems, contact the Marathon® Sales Team at MarathonSales@MarathonEquipment.com

Authorized Dealer:



Marathon Equipment Company | P.O. Box 1798 | Vernon, AL 35592-1798

Learn more about Marathon Equipment: 800.633.8974 | www.marathonequipment.com