

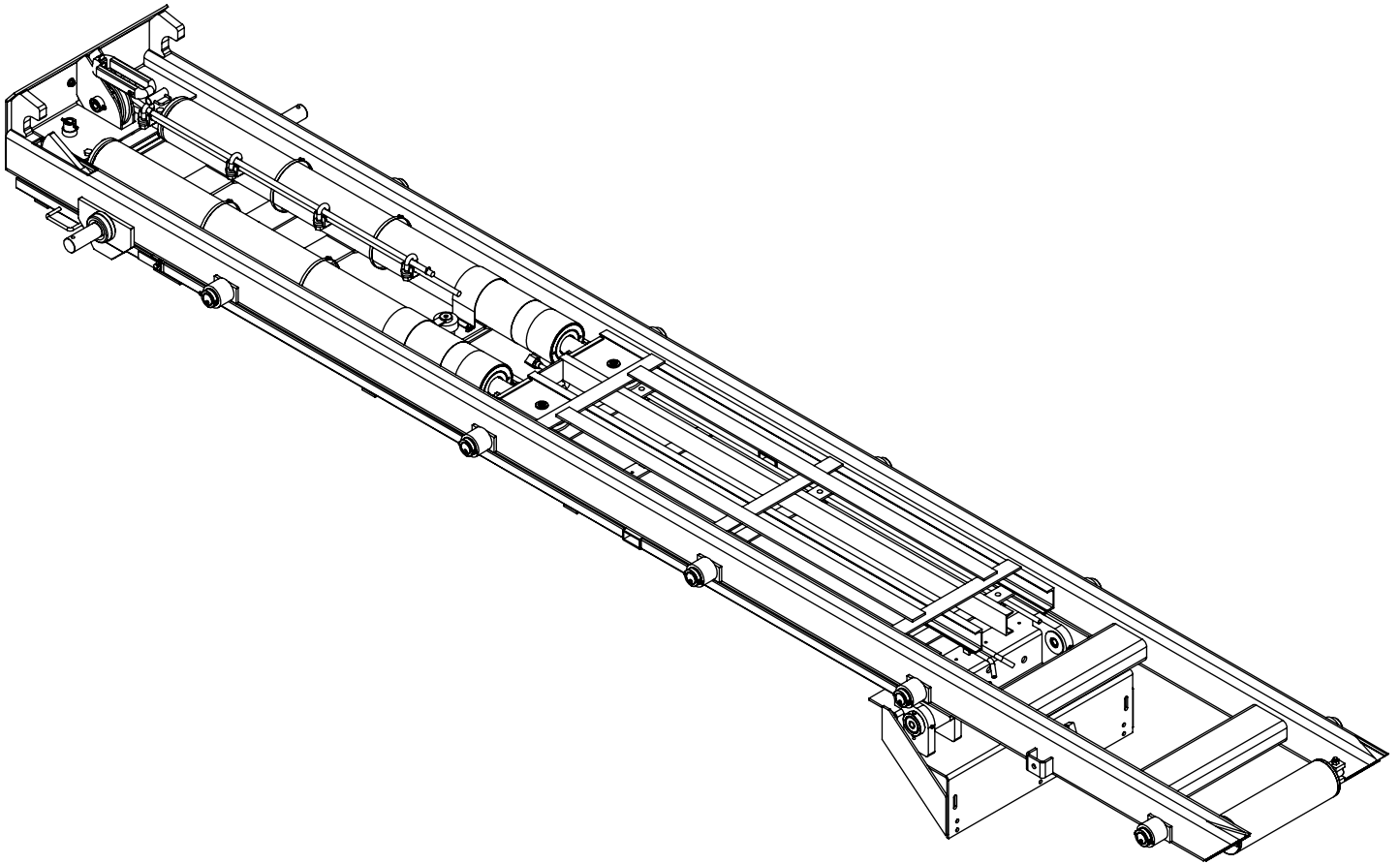

SI CABLE HOIST

OWNERS' MANUAL SI-60 and SI-75 Models

Safety • Operation • Installation • Parts



Stellar Industries, Inc.

190 State Street

PO Box 169

Garner, IA 50438

800-321-3741

Fax: 641-923-2811

www.stellarindustries.com

Subject to Change without Notification.
© 2016 Stellar Industries, Inc.

Last Revision: 06/22/16

Stellar Cable Hoist Manual Revisions

Date of Revision	Section Revised	Description of Revision

Table of Contents

Introduction	iii	Hydraulic Routing - Standard Lift Cylinder	44
Chapter 1 - Safety	1	Hydraulic Routing - Telescopic Lift Cylinder	45
Safety Decals of Note	3	Hydraulic Routing - Reverse Mount Lift Cylinder	46
Chapter 2 - Operation	5	Reverse Mount Lift Cylinder Mounting Kit - PN 56094	47
General Guidelines for Operation of the Cable Hoist	6	Hydraulic Routing - Reeving Cylinder.....	49
Loading Operation	7	Hydraulic Routing - Tail Extension IOX Cylinder Mount	50
Unloading Operation - O.R. and I.O. Models	8	Hydraulic Routing - Tail Extension ORX Cylinder Mount	51
Unloading Operation - Extendable Tail Models	9	Electrical Schematics	52
Correct Roll-Off Container Loads	10	Chapter 7 - Assembly Drawings	53
Unsafe Roll-Off Container Loads.....	10	Main Hoist Assembly	53
Hoist Prop Operation	11	Cable Guide Roller - PN 46029	54
Chapter 3 - Maintenance	13	Reeving Cylinder Assembly - PN 60219	55
Inspection of Sheaves	14	Reeving Cylinder Assembly - PN 60221	55
Cable Replacement	15	Chassis Mounted Parts	56
Choice Lubricants for DX Bearings.....	16	Chassis Mounted Parts	57
Chapter 4 - Specifications	17	Mounting Kit (Forward Mount) - PN 55261	58
Cable Hoist Dimensions.....	18	Mounting Kit (Reverse Mount) - PN 56094	59
Container Subframe	19	Mounting Kit (Telescopic) - PN 55265.....	60
Chapter 5 - Installation	21	Cab Guard - PN 47263	61
General Install Guidelines	21	Under Body Tool Box - PN 46579	62
Truck Chassis Specifications	22	Reservoir Assembly - PN 46133.....	63
Dimensions: 174 Models	23	2 Section Valve Bank Reservoir - PN 45710.....	64
Dimensions: 182 Models	24	3 Section Valve Bank Reservoir - PN 46642.....	65
Dimensions: 194 Models	25	Reservoir Mounting Bracket for PN 45710	66
Step 2: Mount Hoist	26	Standard Lighted Bumper - PN 45887.....	67
Step 3: Mount Lift Cylinders.....	27	Pintle Bumper - PN 46818	68
Mount Lift Cylinders Continued.....	28	ICC Wide Bumper - PN 53397	69
Step 4: Hydraulic Reservoir Installation	28	ICC Heavy Duty Bumper - PN 46809	70
Step 5: Base Clamp Installation.....	29	ICC Bumper Weldment - PN 45574	71
Optional Extender Clamp Install for 182/194 Models	30	ICC Standard Narrow Bumper - PN 48848	72
Step 7: Hydraulic Relief Pressure Setting	31	ICC Narrow Bumper - PN 48846	73
Step 8: Cable Control Installation	31	ICC Extendable Bumper - PN 62663	74
Step 9: Air Control Installation.....	32	Tri-Axle Fenders - PN 46299	75
Optional Controller Bracket.....	33	Tandem Fenders - PN 46122.....	76
Step 10: Bumper Installation	34	Tandem Fenders - PN 46122 Continued.....	77
Bumper Installation Continued.....	35	Tandem Poly Fenders - PN 45795	78
Heavy Duty ICC Bumper Installation	35	Tri-Axle Poly Fenders - PN 45893.....	79
Step 11: Hoist Up Light Installation.....	36	Standard Lift Cylinder - PN 55262	80
Step 12a: Fender Installation - Steel Tandem/Tri-Axle	37	Telescopic Lift Cylinder - PN 51078.....	80
Step 12b: Fender Installation - Plastic Tandem/Tri-Axle	38	Standard Reeving Cylinder - PN 51080.....	81
Step 13: Mid-Body Light Installation	38	Long Reeving Cylinder - PN 51201	81
Step 14a: Removable Stop Installation	39	Tail Extension Cylinder - PN 51202.....	82
Step 14b: Intermediate Stop Installation	40	Tail Extension Cylinder - PN 51203.....	82
Step 15: Reflective Tape Installation	41	Ratchet Strap Kit - PN 45896	83
Step 16: Apply Decals	42	SS Hold Down Kit - PN 60793	84
Chapter 6 - Hydraulics - Electrical	43	CS Hold Down Kit - PN 45326	85
Hydraulic Schematic	43	Chapter 8 - Replacement Parts	87

AN OVERVIEW TO OWNER, OPERATOR AND SERVICE PERSONNEL ABOUT SAFETY

As the owner or employer, it is your responsibility to instruct the operator in the safe operation of this equipment and to provide the operator with properly maintained equipment.

FAILURE TO READ THIS MANUAL BY ANYONE WHO WILL OPERATE, SERVICE, OR WORK AROUND THIS CABLE HOIST IS A MISUSE OF THE EQUIPMENT. DEATH OR SERIOUS INJURY WILL RESULT FROM IMPROPER USE OR MAINTENANCE OF THIS MACHINE.

Occupational safety is a prime concern of Stellar Industries in the design and production of this cable hoist. Our goal in writing this manual was the safety of the operator and others who work around this equipment.

It is your responsibility to know the specific requirements, governmental regulations, precautions and work hazards that exist in the operation and maintenance of this cable hoist. You shall make these available and known to all personnel working with and around the equipment, so that all of you will take the necessary and required safety precautions.

FAILURE TO HEED THESE INSTRUCTIONS CAN RESULT IN SERIOUS INJURY OR DEATH.

It is also your responsibility to operate and maintain your cable hoist with caution, skill, and good judgment. Following the recognized safety procedures will help you avoid accidents. Modification to any part of his cable hoist can create a safety hazard and therefore shall not be made without the manufacturer's written approval. Use only factory approved accessories, options, and parts on this equipment. The rebuilding or remounting of this equipment requires the mounting procedures and retesting to be in accordance with factory instructions. Safety covers and devices must remain installed and maintained in proper working condition. Safety decals must be maintained, be completely legible, and be properly located. If safety covers, devices, or decals are missing, they must be replaced with the proper designated Stellar part.

Be capable, careful, and concerned! Make safety your everyday business!

Attention!

According to Federal Law (49 cfr part 571), each final-stage manufacturer shall complete the vehicle in such a manner that it conforms to the standards in effect on the date of manufacture of the incomplete vehicle, the date of final completion, or a date between those two dates. This requirement shall, however, be superseded by any conflicting provisions of a standard that applies by its terms to vehicles manufactured in two or more stages.

Therefore, the installer of Stellar cable hoists is considered one of the manufacturers of

the vehicle. As such a manufacturer, the installer is responsible for compliance with all applicable federal and state regulations. They are required to certify that the vehicle is in compliance with the Federal Motor Vehicle Safety Standards and other regulations issued under the National Traffic and Motor Vehicle Safety Act.

Please reference the Code of Federal Regulations, title 49 - Transportation, Volume 5 (400-999), for further information, or visit www.gpoaccess.gov/nara/index.html for the full text of Code of Federal Regulations.

Introduction

Stellar Cable hoists are designed to provide safe and dependable service for a variety of operations. With proper use and maintenance, these cable hoists will operate at peak performance for many years.

To promote this longevity, carefully study the information contained in this manual before putting the equipment into service. Though it is not intended to be a training manual for beginners, this manual should provide solid guidelines for the safe and proper usage of the cable hoist.

Once you feel comfortable with the material contained in this manual, strive to exercise your knowledge as you safely operate and maintain the cable hoist. This process is vital to the proper use of the unit.

A few notes on this manual:

A copy of this manual is provided with every cable hoist and shall remain with the cable hoist at all times. Information contained within this manual does not cover all maintenance, operating, or repair instructions pertinent to all possible situations.

Please be aware that some sections of this

manual contain information pertaining to Stellar manufactured cable hoists in general and may or may not apply to your specific model.

This manual is not binding. Stellar Industries, Inc. reserves the right to change, at any time, any or all of the items, components, and parts deemed necessary for product improvement or commercial/production purposes. This right is kept with no requirement or obligation for immediate mandatory updating of this manual.

In closing:

If more information is required or technical assistance is needed, or if you feel that any part of this manual is unclear or incorrect, please contact the Stellar Customer Service Department by phone at 800-321-3741 or email at service@stellarindustries.com.

ATTENTION
Failure to adhere to the instructions could result in property damage or even serious bodily injury to the operator or others close to the cable hoist.

**For Technical Questions, Information, Parts, or Warranty, Call Toll-Free at
800-321-3741**

Hours: Monday - Friday, 8:00 a.m. - 5:00 p.m. CST

Or email at the following addresses:

Technical Questions, and Information

service@stellarindustries.com

Order Parts

parts@stellarindustries.com

Warranty Information

warranty@stellarindustries.com

Chapter 1 - Safety

Please Read the Following Carefully!

This portion of the manual contains information regarding all Stellar manufactured Cable Hoists. Some items contained within this chapter may not apply to your specific equipment.

Safety should be the number one thought on every operator's mind. Three factors should exist for safe operation: a qualified operator, well-maintained equipment, and the proper use of this equipment. The following information should be read and understood completely by everyone working with or near the Cable Hoist prior to putting the unit into operation.

Please take note that Stellar Industries, Inc. is not liable for accidents incurred by the Cable Hoist because of non-fulfillment from the operator's side of current rules, laws, and regulations.

General Safety

It is the responsibility of the owner to instruct the operator in the safe operation of your equipment and to provide the operator with properly maintained equipment.

Trainees or untrained persons shall be under the direct supervision of qualified persons.

Do not operate equipment under the adverse influence of alcohol, drugs, or medication.

Read all safety decals on the equipment and understand their meaning.

Personal Safety

Keep clear of all moving parts.

Never allow anyone under any portion of the hoist unless the hoist is firmly resting in the hoist props.

Always wear the prescribed personal safety

devices.

Always wear approved accident-prevention clothing such as: protective helmets, anti-slip shoes with steel toes, protective gloves, anti-noise headphones, protective glasses, breathing apparatus, and reflective jackets. Consult your employer regarding current safety regulations and accident-prevention equipment.

Do not wear rings, wristwatch, jewelry, loose-fitting or hanging clothing such as ties, torn garments, scarves, unbuttoned jackets or unzipped overalls, which could get caught up in the moving parts of the Cable Hoist.

Keep a first-aid box and a fire extinguisher readily available on the truck. Regularly check to make sure the fire extinguisher is fully charged and the first-aid kit is stocked.

Do not use controls and hoses as hand-holds. These parts move and cannot provide stable support.

Do not allow unauthorized personnel or equipment to enter within 10 feet of Cable Hoist operating area.

Never allow anyone to ride the Cable Hoist or load.

Operation Safety

Never operate the hoist unless the hydraulic system, including the cylinders and lines, are full of oil and free of air.

Check the area for power lines and overhead obstructions.

Do not load, dump or unload a container on uneven ground.

Do not move the truck while the hoist and container are raised. A raised load creates

a top heavy unstable load.

Do not use a chain between the reeving cable and the container. A chain will not withstand the force applied to the cable.

Do not use any method to hold a valve open which will not let the valve close automatically when released.

Always keep the cable centered on the hoist frame. Do not allow the cable to rub on any surface when loading or unloading a container.

Do not operate the reeving cylinders to load or unload a container unless the front of the hoist frame is above the top of the truck cab.

ATTENTION

Stellar Industries, Inc. is not liable for accidents incurred by the Cable Hoist because of the operator's non-fulfillment of current rules, laws and regulations.

Maintenance Safety

Never modify or alter any of the equipment, whether mechanical, electrical, or hydraulic, without Stellar Industries' approval.

Be sure safety decals are clean and in place.

Check the reeving cable for wear and fraying.

Do not perform any maintenance or repair work on the Cable Hoist unless authorized and trained to do so.

Release system pressure before attempting to make adjustments or repairs.

Do not attempt service or repair when PTO is engaged.

Safety Decals of Note

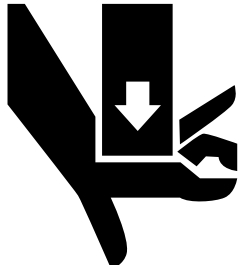

WARNING

CRUSHING HAZARD

Moving parts can crush and cut. Keep hands and arms clear.

25627

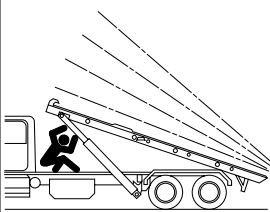

WARNING

BEFORE WORKING AROUND A RAISED HOIST, THE HOIST MUST BE SUPPORTED BY THE HOIST PROP.
(SEE HOIST PROP. OPERATING INSTRUCTIONS)

FAILURE TO DO SO COULD RESULT IN SERIOUS INJURY OR DEATH. IF THE HOIST PROPS CANNOT BE USED, CONSULT THE MAINTENANCE SECTION OF THE OPERATION MANUAL FOR THE PROPER PRECAUTIONS.

45553

DANGER

STAND CLEAR

WHEN THIS UNIT IS IN OPERATION!

FAILURE TO DO SO COULD RESULT IN SERIOUS PERSONAL INJURY.

45557

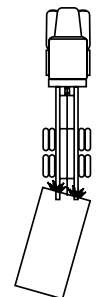

WARNING

DO NOT ATTEMPT TO LOAD A CONTAINER UNLESS THE HOIST AND CONTAINER ARE CORRECTLY ALIGNED.

KEEP THE CONTAINER RAILS SAFELY ENGAGED WITH THE HOIST RAILS AND ROLLERS.

FAILURE TO DO SO COULD CAUSE THE CONTAINER TO SLIDE OFF THE SIDE OF THE HOIST OR JAM ON THE RAILS.

45592

CAUTION

DO NOT ATTEMPT TO OPERATE THIS EQUIPMENT WITHOUT PROPER TRAINING.

PERSONAL INJURY AND EQUIPMENT DAMAGE CAN OCCUR IF THIS EQUIPMENT IS USED IMPROPERLY. READ AND UNDERSTAND THE OPERATION MANUAL.

45693

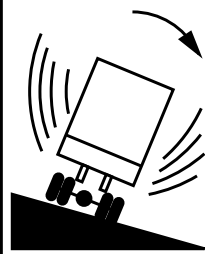

WARNING

DO NOT LOAD, UNLOAD OR DUMP CONTAINER ON UNEVEN GROUND.

A LOADED CONTAINER CREATES A TOP HEAVY LOAD. USE CAUTION WHEN DRIVING ON UNEVEN GROUND AND TURNING CORNERS.

SERIOUS PERSONAL INJURY AND EQUIPMENT DAMAGE COULD RESULT.

45695

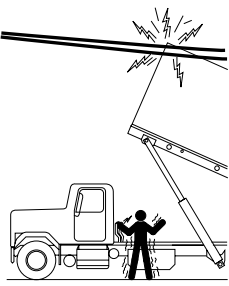

DANGER

BE AWARE OF POWER LINES AND OVERHEAD OBSTRUCTIONS.

CONTACT BY THE HOIST OR CONTAINER COULD CAUSE SERIOUS INJURY OR DEATH TO THE OPERATOR AND BYSTANDERS.

45696

CAUTION

DO NOT EXCEED 1600 ENGINE RPM WHEN OPERATING POWER TAKE OFF!

45697



WARNING

RAISE HOIST ABOVE THE TOP OF THE TRUCK CAB BEFORE LOADING OR UNLOADING A CONTAINER, UNLESS A CAB GUARD IS INSTALLED.

CABLE FAILURE COULD RESULT IN SERIOUS PERSONAL INJURY AND EQUIPMENT DAMAGE.

45698

WARNING

Escaping fluid under pressure can penetrate the skin causing serious injury or death. Relieve pressure before disconnecting hydraulic lines, tighten all connections before applying pressure, and inspect all lines before each use. See "Safety" section in operation manual for additional information.

If an accident occurs, see a doctor immediately. Any fluid injected into the skin must be surgically removed within a few hours or gangrene may result.



45726
74-276

Chapter 2 - Operation

Job-Site Set-Up

Thoroughly plan the lift before positioning the vehicle. Consider the following:

1. The vehicle should be positioned in an area free from overhead obstructions to eliminate the need for repositioning.
2. Position the vehicle so that it is impossible for any portion of the equipment to come within the minimum required safe distance of any power line. Maintain a clearance of at least 10 feet between any part of the Cable Hoist, load line, or load, and any electrical line or apparatus carrying up to 50,000 volts. One foot additional clearance is required for every additional 30,000 volts or less. Remember to allow for winds that cause power lines to sway. It is recommended that a signal person be used when the vehicle is set-up near power lines.
3. The vehicle should also be positioned on a firm and level surface that will provide adequate support for the body.
4. The parking brake must be removed to allow the truck to roll under the body while loading.

Cable Hoist Controls

1. Be familiar with the sequence and operation of the Cable Hoist controls.
2. Each individual Cable Hoist function should have control function decals. Replace them immediately if they are missing or illegible.
3. Keep hands, feet and control levers free from mud, grease and oil.
4. Be familiar with the control levers and how they operate before attempting to operate the Cable Hoist.
5. Be prepared before beginning operation of the Cable Hoist:
 - All protective guards must be in place.
 - Be aware of the surroundings: low branches, power lines, unstable ground.
 - Be sure all safety devices provided are in place and in good operating condi-

tion.

- Be prepared for all situations. Keep fire extinguisher and first aid kit near.
- Be sure all regular maintenance has been performed.
- Visually inspect all aspects of the Cable Hoist for physical damage.
- Check for fluid leaks.

Operator Requirements

Operation is limited to the following people:

1. Qualified individual.
2. Trainees under direct supervision of the qualified individual.
3. Test or maintenance individual.
4. Cable Hoist Inspector.

Operators must:

1. Demonstrate the ability to understand all decals, the owner's manual, and any other information required for safe operation of the Cable Hoist.
2. Be able to demonstrate the ability to safely control the Cable Hoist.
3. Know all safety regulations.
4. Be responsible for maintenance requirements.
5. Understand and be fully capable of implementing all emergency procedures.
6. Understand the operating procedures as outlined by this manual, ANSI B30.5 and Federal/State Laws.

Operator Conduct

1. Operators will not engage in any operation that would cause them to divert attention away from the operation of the Cable Hoist.
2. Operators are responsible for all operations under their direct control.
3. Operators will not leave a suspended load unattended.
4. Operators will be familiar with the equipment and the maintenance required for proper care.

General Guidelines for Operation of the Cable Hoist

Loading a Container

1. Back the truck up to the container to be loaded and align the hoist rails with the container long sills. Caution: Be sure the area in which the hoist is to be operated is clear of personnel and obstacles - overhead and on the ground.
2. Engage the PTO and raise the hoist until the rear roller is on the ground.
3. Set the parking brakes and retract the reeving cylinders to connect the cable to the container. Caution: Do not attempt to load a container with faulty equipment. Check the condition of the cable, cable end, and container cable connection. Never lift a container heavier than the rated capacity of the hoist.
4. Release the parking brake and allow the truck to roll under the container. Extend the reeving cylinders to pull the container onto the hoist. The container long sills must be kept on the hoist rollers.
5. Once the center of gravity of the container is in front of the rear hinge, the hoist can be lowered until the front is just above the top of the truck cab.
6. Continue pulling the container forward until it is securely locked into the front stops. Caution: Rear hold-down devices are required on the hoist and the containers.
7. Lower the hoist to the full-down position and disengage the PTO.

Dumping a Container

1. While the hoist is in the full-down position, open the container door and secure it. Caution: Be sure that the truck is on firm, level ground before dumping. If one side of the load breaks loose in this high center of gravity position, a truck on unstable footing may roll over on its side.
2. Engage the PTO and raise the hoist until the load slides out of the container. Caution: Do not pull forward until the hoist is lowered to the full-down position.

3. Lower the hoist to the full-down position and disengage the PTO.

Unloading a Container (O.R. and I.O.)

1. Back the truck up in front of where the container is to be spotted. Allow room for the container to roll off of the hoist.
2. Raise the hoist and retract the reeving cylinders. Allow gravity to pull the container to the ground.
3. Once the rear rollers are on the ground, allow the truck to roll out from under the container.
4. Once the container is on the ground, lock the truck brakes and disconnect the cable and secure it to the hoist.
5. Lower the hoist to the full down position. Pull away from the container. Disengage the PTO.

Unloading a Container (Extendable Tail)

1. Back the truck up in front of where the container is to be spotted. Allow room for the container to roll-off of the hoist.
2. Raise the hoist and retract the reeving cylinders. Allow gravity to pull the container to the ground. Once the rear rollers are on the ground, allow the truck to roll out from under the container.
3. Alternate extending the cable and the tail until the container is on the ground.
4. Lock the truck brakes and disconnect the cable and secure it to the hoist.
5. Lower the hoist and retract the tail section. Disengage the PTO before driving away.

Cable Hoist Check List

1. **Check hydraulic oil level with all cylinders retracted.**
2. **Grease all lubrication points.**
3. **All rollers and sheaves are free to rotate.**
4. **Tires are properly inflated.**
5. **The container lock is free to move and works properly.**

Loading Operation

- ① Back the truck up to the container to be loaded and align the hoist rails with the container long sills.

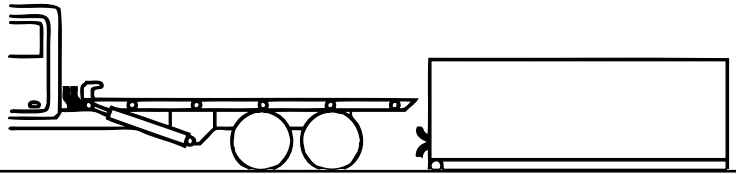

- ② Engage the PTO and raise the hoist until the rear roller is on the ground.

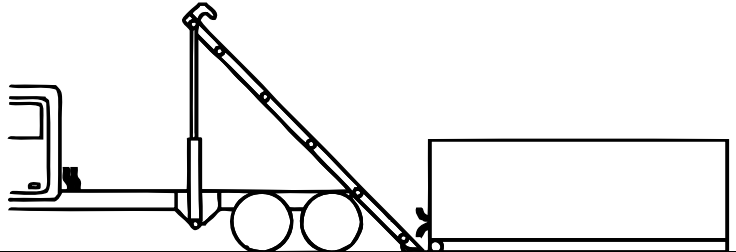

- ③ Set the parking brakes and retract the reeving cylinders to connect the cable to the container.

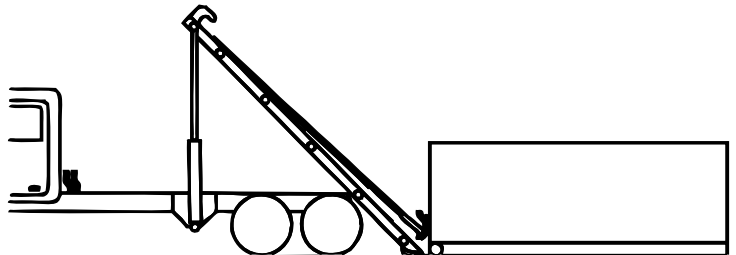

- ④ Release the parking brake and allow the truck to roll under the container. Extend the reeving cylinders to pull the container onto the hoist. The container long sills must be kept on the hoist rollers.

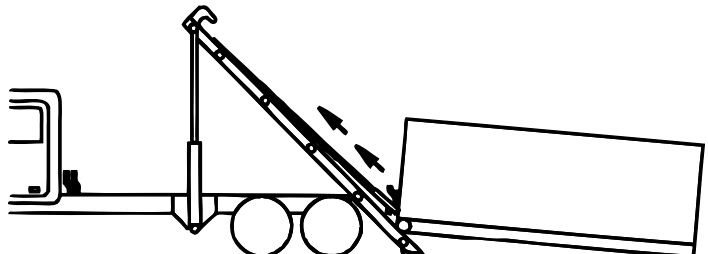

- ⑤ Once the center of gravity of the container is in front of the rear hinge, the hoist can be lowered until the front is just above the top of the truck cab.

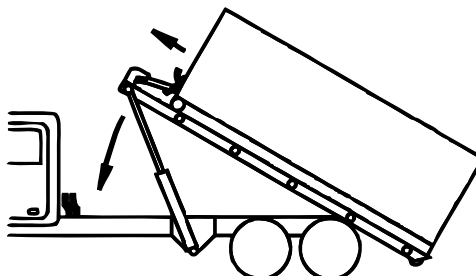

- ⑥ Continue pulling the container forward until it is securely locked into the front stops. Caution: Rear hold-down devices are required on the hoist and the containers.

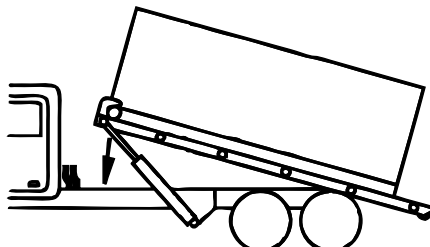

- ⑦ Lower the hoist to the full-down position and disengage the PTO.

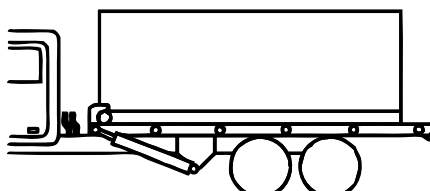

Unloading Operation - O.R. and I.O. Models

- ① Back the truck up in front of where the container is to be spotted. Allow room for the container to roll-off of the hoist.

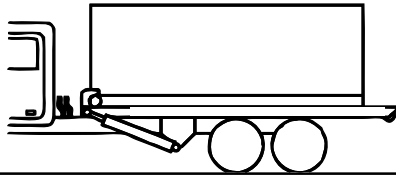

- ② Raise the hoist and retract the reeving cylinders. Allow gravity to pull the container to the ground.

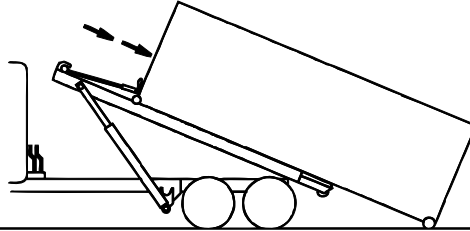

- ③ Once the rear rollers are on the ground, allow the truck to roll out from under the container.

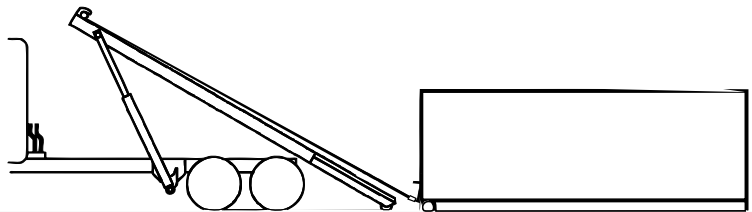

- ④ Once the container is on the ground, lock the truck brakes and disconnect the cable and secure it to the hoist.

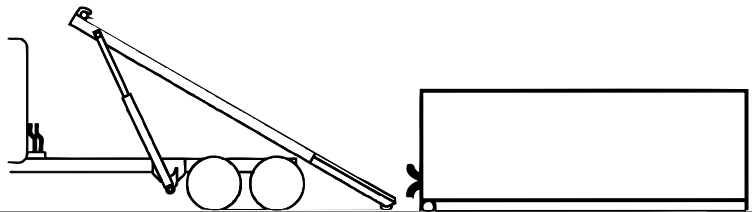

- ⑤ Lower the hoist to the full down position. Pull away from the container. Disengage the PTO.

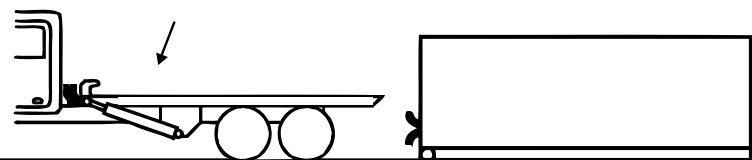

Unloading Operation - Extendable Tail Models

- ① Back the truck up in front of where the container is to be spotted. Allow room for the container to roll-off of the hoist.

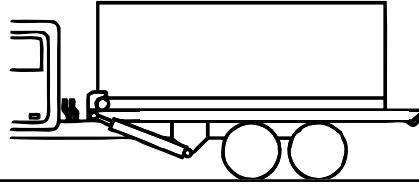

- ② Raise the hoist and retract the reeving cylinders. Allow gravity to pull the container to the ground. Once the rear rollers are on the ground, allow the truck to roll out from under the container.

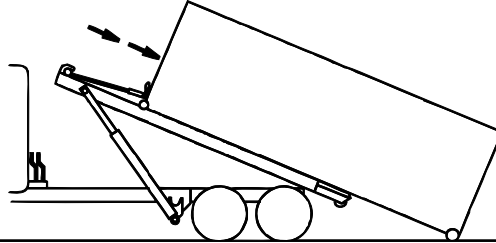

- ③ Alternate extending the cable and the tail until the container is on the ground.

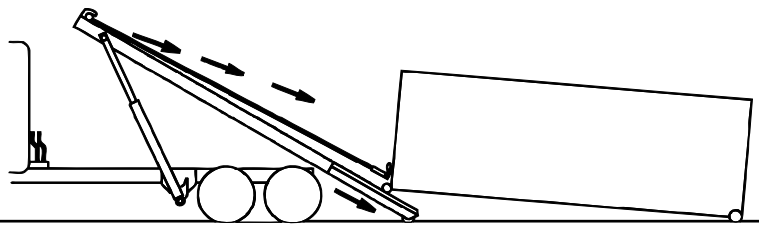

- ④ Lock the truck brakes and disconnect the cable and secure it to the hoist.

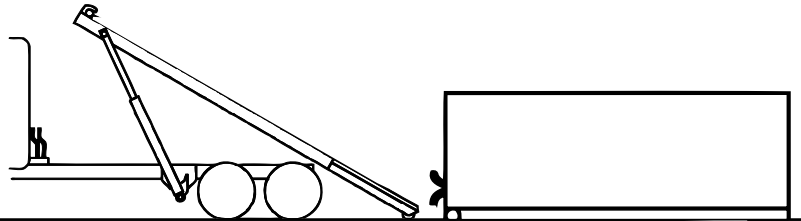

- ⑤ Lower the hoist and retract the tail section. Disengage the PTO before driving away.

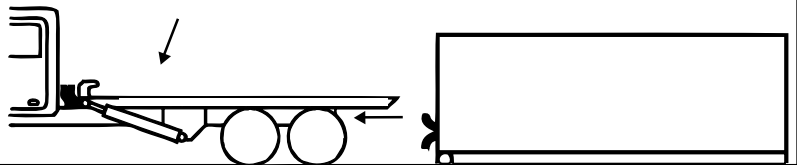

Correct Roll-Off Container Loads

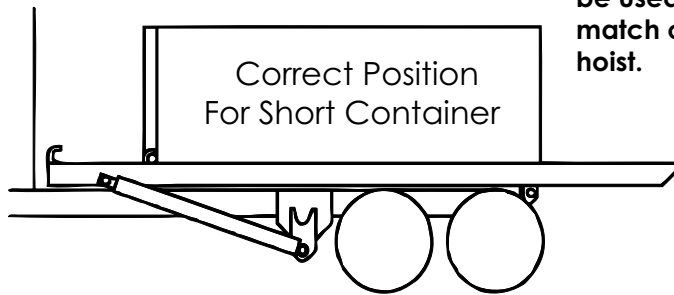
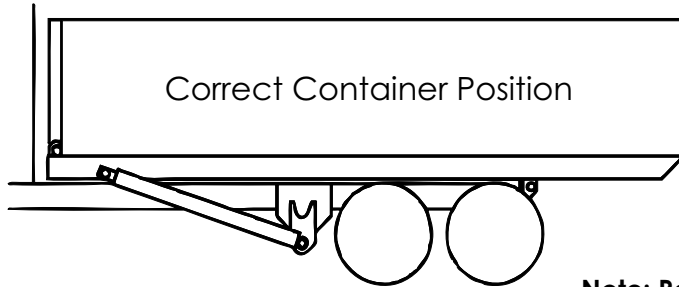

Note: Removable front stops must be used and rear hold downs must match on container and roll-off hoist.

Unsafe Roll-Off Container Loads

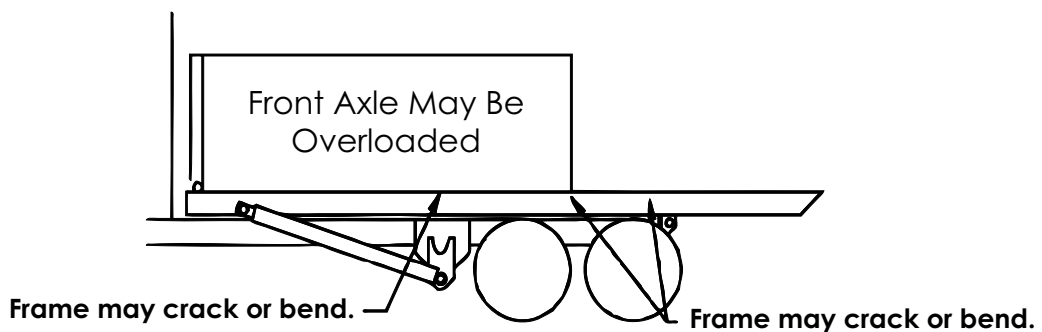
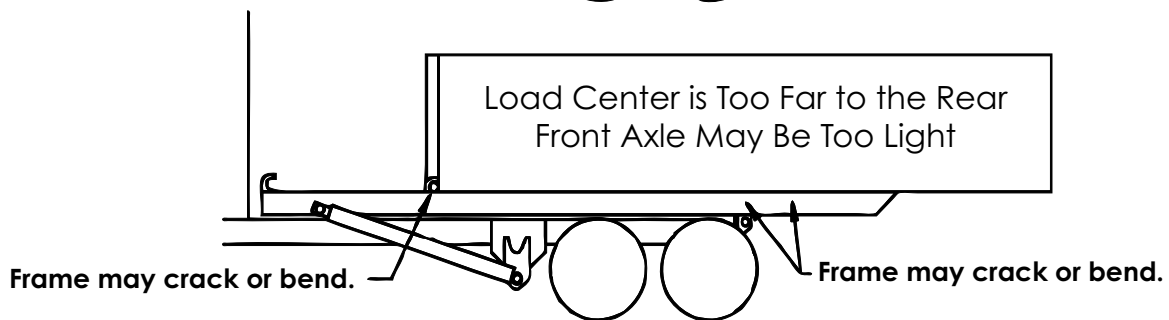
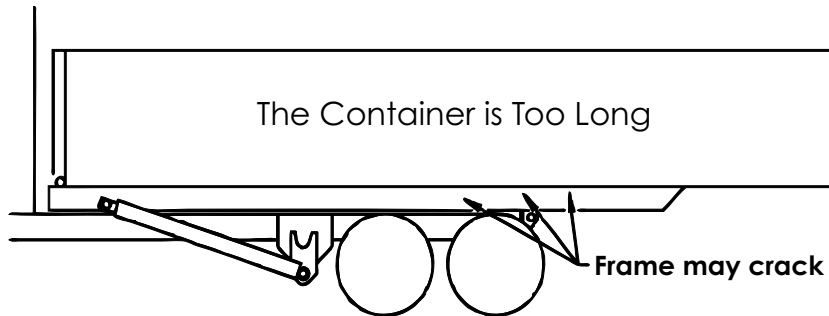

Hoist Prop Operation

WARNING

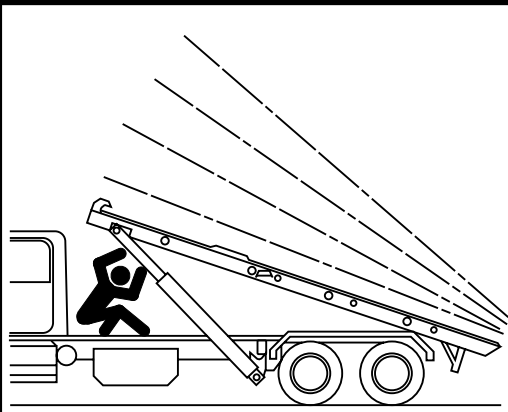

BEFORE WORKING AROUND A RAISED HOIST, THE HOIST MUST BE SUPPORTED BY THE HOIST PROP.

(SEE HOIST PROP OPERATING INSTRUCTIONS)

FAILURE TO DO SO COULD RESULT IN SERIOUS INJURY OR DEATH.

IF THE HOIST PROPS CANNOT BE USED, CONSULT THE MAINTENANCE SECTION OF THE OPERATION MANUAL FOR THE PROPER PRECAUTIONS.

45553

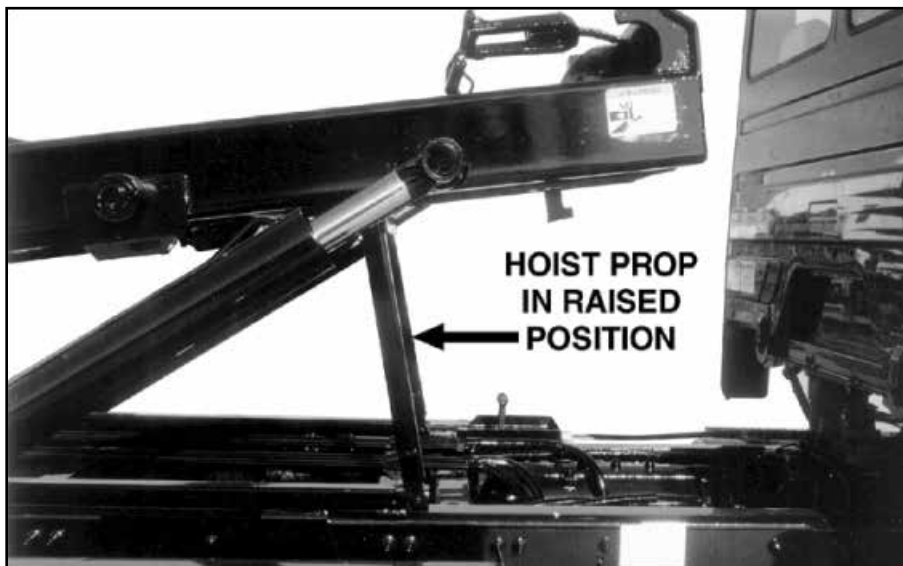
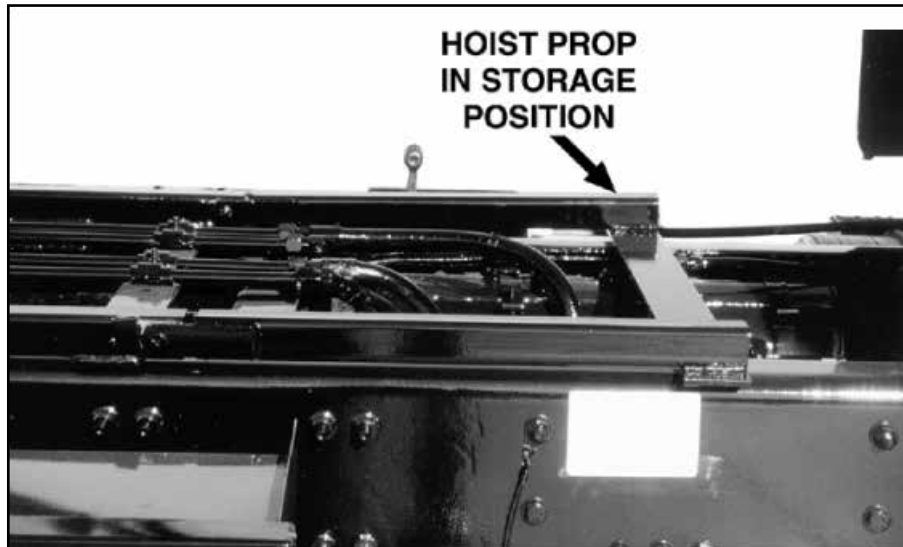

Chapter 3 - Maintenance

Please read the following before performing any maintenance on the Cable Hoist.

1. Only authorized service personnel are to perform maintenance on the Cable Hoist.
2. Disengage the PTO before any service or repair is performed.
3. Do not disconnect hydraulic hoses while there is still pressure in those components.
4. Before disconnecting hydraulic components, shut off the engine, release any air pressure on the hydraulic reservoir, and move control levers repeatedly through their operating positions to relieve all pressures.
5. Keep the Cable Hoist clean and free from grease build-up, oil and dirt to prevent slippery conditions.
6. Perform all safety and maintenance checks before each period of use.
7. Replace parts with Stellar Industries, Inc. approved parts only.
8. Immediately repair or have repaired any components found to be inadequate.

Maintenance Procedures

1. Position the Cable Hoist where it will be out of the way of other operations or vehicles in the area.
2. Place all controls in the off position and secure operating features from inadvertent motion.
3. Relieve hydraulic oil pressure from all hydraulic circuits before loosening or removing hydraulic components.
4. Label or tag parts when disassembling.

Periodic Inspection

Periodic Inspection should occur while the Cable Hoist is in use. For the duration of the usage, inspect the Cable Hoist for all of the following:

1. Loose bolts and fasteners.
2. All pins, bushings, shafts, and gears for wear, cracks, or distortion to include all pivot points, and bushings.
3. Hydraulic systems for proper operating pressure.
4. Main frame mount bolts.
5. Cylinders for:
 - A. Damaged rods.
 - B. Dented barrels.
 - C. Drift from oil leaking internally.
 - D. Leaks at rod seals or holding valves.
6. PTO and hydraulic pump(s) for leaks.
7. Hydraulic hose and tubing for evidence of damage such as blistering, crushing, or abrasion.
8. Presence of this owner's manual.

Daily Inspection

Daily Inspection should occur each day before the Cable Hoist is put into use. Each day, inspect the Cable Hoist for all of the following:

1. Hydraulic oil level.
2. Loose parts or damage to structures or weld.
3. Cylinder movement due to leakage.
4. Hoses for evidence of oil leaks.
5. Controls for malfunction or adjustment.
6. Parking brake operation.
7. All securing hardware such as cotter pins, snap rings, hairpins, and pin keepers for proper installation.
8. All safety covers for proper installation.
9. Cylinder holding valves for proper operation.
10. Equipment for missing, illegible, or defaced operating decals and safety signs.
11. Inspect the wire rope for fraying or other wear.

Monthly Inspection

Monthly Inspection should occur at the beginning of every work month. Each month, inspect the Cable Hoist for all of the following:

1. Frame bolt tightness - turn barrel nuts and mounting bolts during the first month of operation on new machines and then quarterly thereafter.
2. Cylinders and valves for leaks.
3. Lubrication.
4. Structural weldments for bends, cracks, or breaks.
5. All pins and keepers for proper installation.
6. All control, safety, and capacity placards for readability and secure attachment.
7. Inspect all electrical wires and connections for worn, cut, or deteriorated insulation and bare wire. Replace or repair wires as required.
8. Lubrication of all points requiring lubrication.

General Service

The following general suggestions should be helpful in analyzing and servicing your Cable Hoist. Using the following systematic approach should be helpful in finding and fixing problems:

1. Determine the problem.
2. List and record possible causes.
3. Devise checks.
4. Conduct checks in a logical order to determine the cause.
5. Consider the remaining service life of components against the cost of parts and labor necessary to replace them.
6. Make the necessary repair.
7. Recheck to ensure that nothing has been overlooked.
8. Functionally test the new part in its system.

Inspection of Sheaves

Under normal conditions, machines should receive periodic inspections, and their overall condition recorded. Such inspections usually include the sheaves, and any other parts that may come into contact with the wire rope and subject it to wear. As an additional precaution, rope related working parts, particularly in the area described below, should be re-inspected prior to the installation of a new cable.

The very first item to be checked when examining the sheaves is the condition of the grooves. To check the size, contour and amount of wear, a groove gage is used. As shown in the illustration to the right of this paragraph, the gage should contact the groove for about 150° of arc.

Two types of groove gages are in general use and it is important to note which of these is being used. The two differ by their respective percentage over nominal.

For new or re-machine grooves, the groove gage is nominal plus the full oversize percentage. The gage carried by most wire rope representatives today is used for worn grooves and is made nominal plus 1/2 the oversize percentage.

The latter gage is intended to act as a sort of "no-go" gage. Any sheave with a groove smaller than this must be replaced or, in all likelihood, the existing rope will be damaged.

Experience has clearly demonstrated that the service life of the wire rope will be materially increased by strict adherence to these standards.

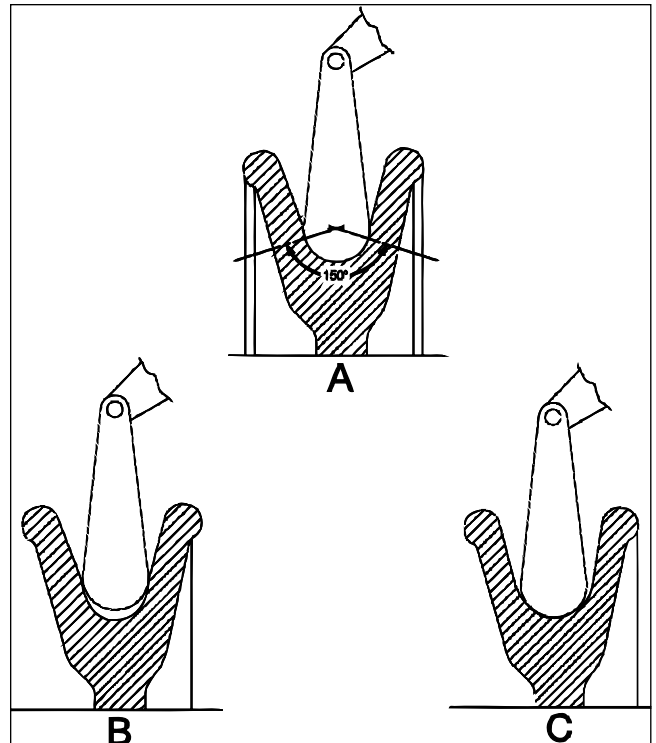

Cross-sections illustrating three sheave-groove conditions. A is correct, B is too tight, and C is too loose.

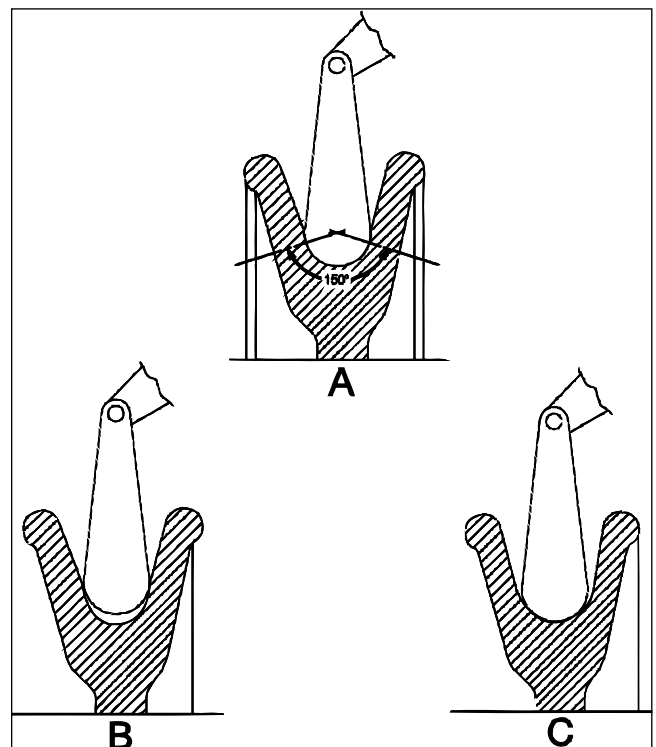

Cross-sections illustrating three sheave-groove conditions. A is correct, B is too tight, and C is too loose.

Cable Replacement

Important: Standard replacement cable must be 7/8" diameter 6 x 37 extra improved plow steel with steel core (6 x 37 EXIWRC) with a 4.00" swaged button x 75' (174" & 182" CT, or) 77 feet (194" CT) in length.

1. Remove the cable clamps and discard the old cable.
2. Inspect all the sheaves (See Inspection of Sheaves on page 12).
3. Install cable end onto cable. Thread cable through sheaves and guides, etc. Loop cable through cable anchor and install clamps following the diagram below. Torque all bolts evenly to 225 ft. lbs.

CABLE CLAMP DETAIL

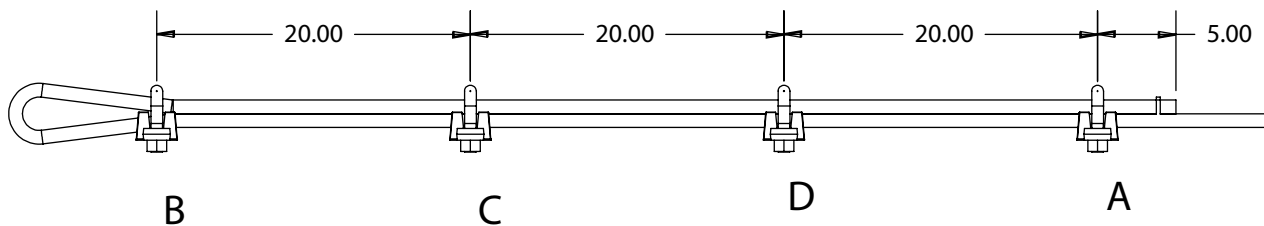

CLAMP INSTRUCTIONS

1. INSTALL CLAMP "A" TORQUE NUTS TO 225 FT-LBS.
2. INSTALL CLAMP "B" SNUG NUTS ON CABLE.
3. INSTALL CLAMPS "C" & "D" AS SHOWN SNUG NUTS.
4. APPLY TENSION TO CABLE.
5. TORQUE NUTS ON "B", "C" & "D" TO 225 FT-LBS.
6. CLAMP NUTS MUST FACE DOWN.

Cleanliness

An important item in preserving the long life of the cable hoist is keeping dirt, grime, and corrosive material out of the working parts. Thoroughly wash and grease the cable hoist periodically.

Choice Lubricants for DX Bearings

Greases Recommended

Type of Grease	Description
Premium Quality Multi-Purpose	Stabilized, Anti-Oxidant Lithium Base Lithium Base with 3% Molybdenum Disulfide High Drop Point
Multi-Purpose	Calcium Based, for General Automotive and Industrial Use Calcium Grease, Water Stabilized, High Drop Point
Anti-Friction Bearing	Calcium Based with EP Additives Lithium Based Sodium Based
Extreme Pressure (EP)	Lithium Based with EP Additives Calcium Based with EP Additives
High Temperature	Modified Sodium Based, High Drop Point
Transmission	Semi-Fluid, Calcium Based
Molybdenum Filled	Lithium Based with 2% Molybdenum Disulfide
Graphite Filled	Sodium Based with 2% Graphite
Block Grease	Sodium Based Solid Grease
White Grease	Aluminum Complex Based with Anti-Oxidant & Rust Inhibitors & Zinc Oxide Additives
Silicone	Lithium Based with Silicone Oil Lubricant

Greases Not Recommended

Type of Grease	Description
Cup Grease	Light Service Calcium or Sodium Based Grease
Graphite Filled	Greases with More than 10% Graphite
Molybdenum Filled	Greases with More than 10% Molybdenum Disulfide
Fluorocarbon	Low Molecular Weight Chlorofluoroethylene Polymer with Inert Thickeners
White Grease	Calcium Based, Zinc Oxide Filled

Chapter 4 - Specifications

Chassis C.T.:	See chart on next page.		
Frame Width:	35-1/2"		
Minimum GVWR:	18,000 lbs. Front, 44,000 lbs. Rear		
Frame Height:	43"		
Sub-Frame:	Full length 2 x 4 Tube		
Load Rating:	60,000 lbs., 75,000 lbs.		
Dump Angle:	47°		
Operating Pressure:	1,850 PSI (60,000 lbs), 2,150 PSI (75,000 lbs)		
Gear Pump:	35 GPM @ 1,500 RPM		
Operation:	Inside Cab Cable Controls Standard		
Shipping Dimensions:	300"L x 54"W x 39"H		
Weight:	6,400 lbs. - 7,400 lbs.		
Cylinders:	Twin Double Acting		
	6 x 72	Lift	Model SI-60/75
	7 x 80	Reeving	Model SI-60/75
	7 x 90	Reeving	Model SI-60/75
Low Pressure Hydraulic System			
Gear Driven Hydraulic Pump			
Large 3" Rear Pivot Pin			
Hold-down compatible with ANSI Z245.6 Type "U" Containers			

Cable Hoist Dimensions

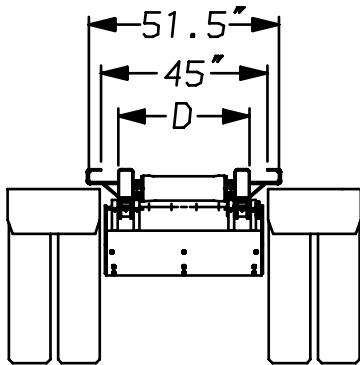

Specifications Chart						
Models	A	B	C	D	CT (Cab to Trunnion)	
					w/o Autotarper	w/ Autotarper
SI-60-174 OR/IO	281"	210"	174"	35.5"	174"	180"
SI-60-182 OR/IO	289"	218"	174"	35.5"	182"	188"
SI-60-194 OR/IO	301"	230"	186"	35.5"	194"	200"
Extended Tail Models						
Extended Tail Models	A	B	C	D	CT (Cab to Trunnion)	
					w/o Autotarper	w/ Autotarper
SI-60-174 ORX	237"	210"	174"	35.5"	174"	180"
SI-60-182 ORX	245"	218"	174"	35.5"	182"	188"
SI-60-194 ORX	257"	230"	186"	35.5"	194"	200"
SI-60-174 IOX	278.5"	210"	174"	35.5"	174"	180"
SI-60-182 IOX	286.5"	218"	174"	35.5"	182"	188"
SI-60-194 IOX	298.5"	230"	186"	35.5"	194"	200"

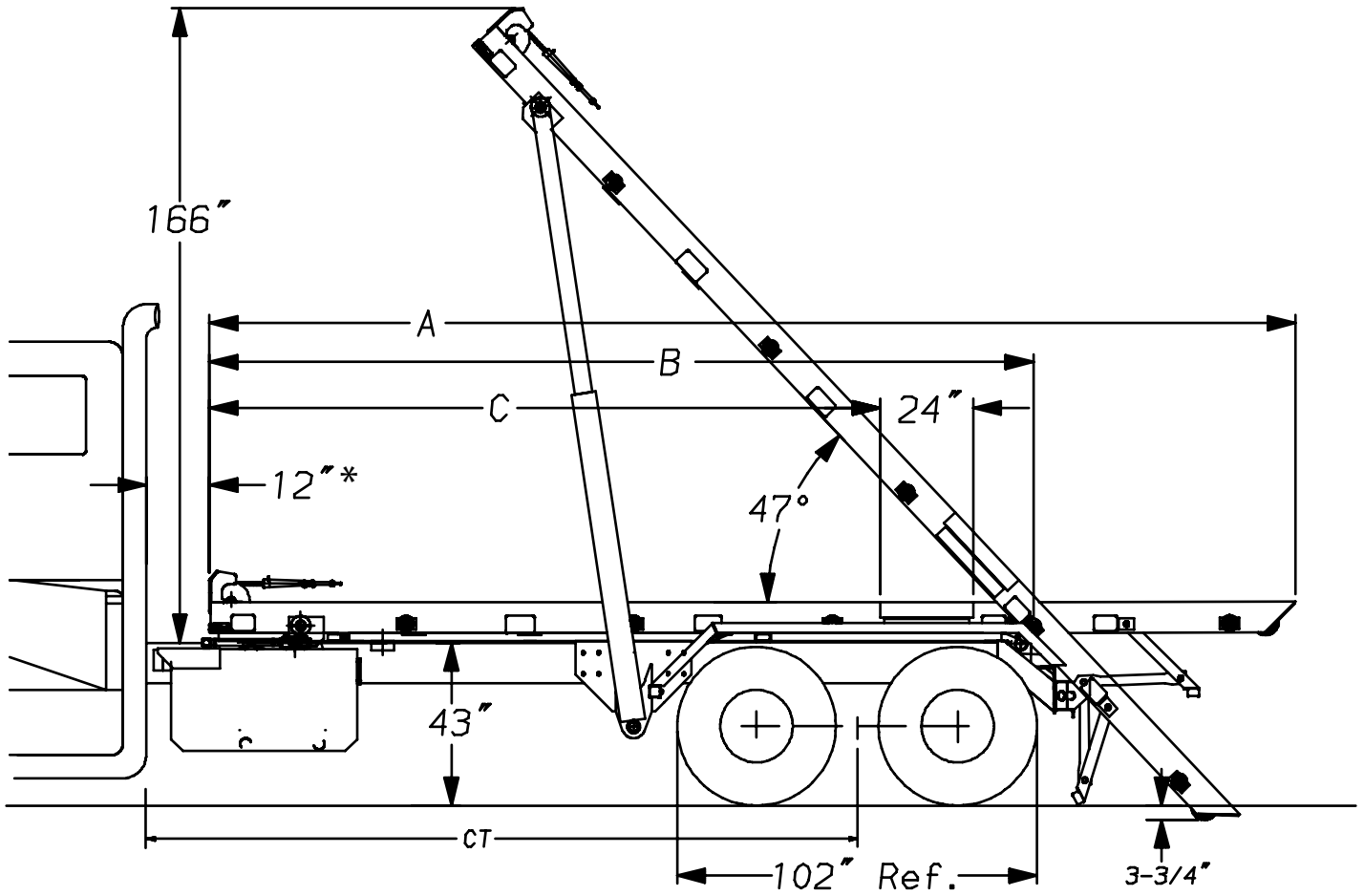

*Autotarper installation requires 12" of unobstructed space behind the truck cab.

Container Subframe

NOTE:
ALL DIMENSIONS ARE IN ACCORDANCE WITH
ANSI Z245.60 TYPE "U" CONTAINER REQUIREMENTS

FRONT VIEW

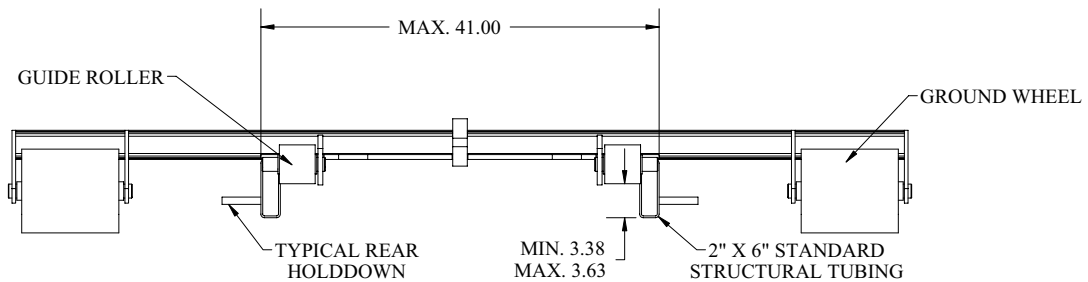

SIDE VIEW

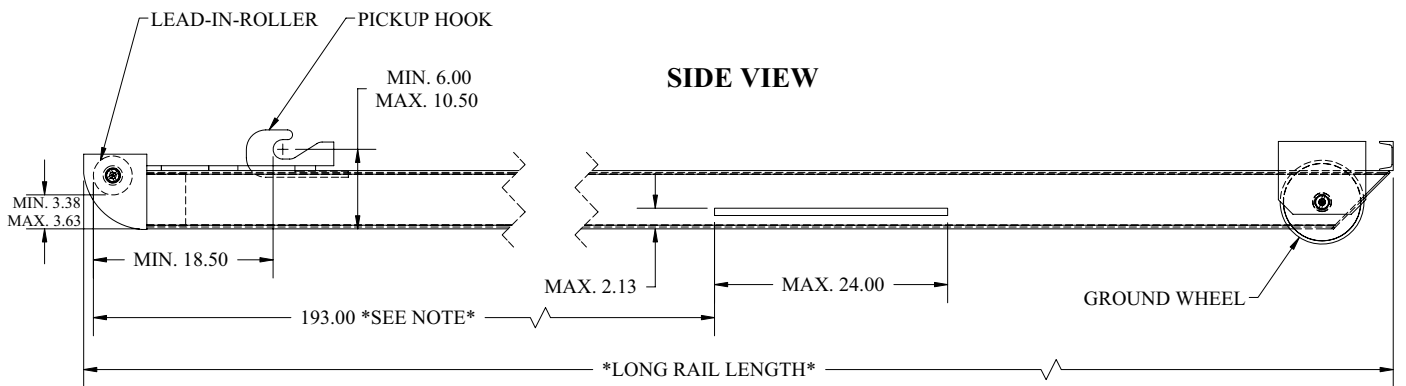

NOTE

IF LONG RAIL LENGTH IS GREATER THAN OR EQUAL TO 12FT. AND LESS THAN 18FT, REAR HOLDDOWN DIMENSION IS 147.50 IN. PLUS 1 IN. MINUS 0 IN. FROM FRONT OF LEAD-IN-ROLLER TO THE FRONT OF THE HOLDDOWN.

IF LONG RAIL LENGTH IS GREATER THAN OR EQUAL TO 18FT. AND LESS THAN 24FT, REAR HOLDDOWN DIMENSION IS 193.00 IN. PLUS 1 IN. MINUS 0 IN. FROM FRONT OF LEAD-IN-ROLLER TO THE FRONT OF THE HOLDDOWN.

Chapter 5 - Installation

General Install Guidelines

Cable Hoist Mounting and Assembly

Study names and locations of the parts and familiarize yourself with the Cable Hoist before starting the assembly. Reading the step-by-step instructions that follow will be helpful.

Safety

Read all of the safety notations in the assembly instructions for your protection. Accidents can be prevented by recognizing the cause of an accident before it can happen.

Assembly

Select an area for assembly that will be large enough to accommodate the completed unit. The surface of the work area should be as level as possible. Use the proper hand tools to ensure proper bolt tightness. Refer to the chart below for the recommended torque values for different sizes of bolts.

Recommended Torque Values in Foot Pounds

For SAE GRADE 2 and GRADE 5 coarse thread cap screws and bolts shown are suggested maximum for fasteners, carrying only the residue oil of the manufacturer.

Proper Bolt Use

Do not use these values if a different torque value or tightening procedure is given for a specific application. Torque values listed are for general use only. Check tightness of fasteners periodically.

Sheer bolts are designed to fail under pre-determined loads. Always replace shear bolts with identical grade.

Fasteners should be replaced with the same or higher grade. If higher grade fasteners are used, these should only be tightened to

the strength of the original.

Tighten plastic insert or crimped steel-type lock nuts to approximately 110 percent of the dry torque values shown in the chart below, applied to the nut, not to the bolt head. Tighten toothed or serrated-type lock nuts to the full torque value.

Note: "Lubricated" means coated with a lubricant such as engine oil, or fasteners with phosphate and oil coatings. "Dry" means plain or zinc plated without lubrication. Tighten lubricated bolts to approximately 80% of dry bolts.

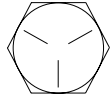
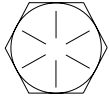
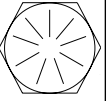
		Grade 5		Grade 8		Grade 9	
							
Model Number							
Size (DIA-TPI)	Bolt DIA (Inches)	Plain (Ft-Lb)	Plated (Ft-Lb)	Plain (Ft-Lb)	Plated (Ft-Lb)	Plated (Ft-Lb)	
5/16-18	0.3125	17	13	25	18	22	
3/8-16	0.3750	31	23	44	33	39	
7/16-14	0.4375	49	37	70	52	63	
1/2-13	0.5000	75	57	105	80	96	
9/16-12	0.5625	110	82	155	115	139	
5/8-11	0.6250	150	115	220	160	192	
3/4-10	0.7500	265	200	375	280	340	
7/8-9	0.8750	395	295	605	455	549	
1-8	1.000	590	445	910	680	823	
1 1/8-7	1.1250	795	595	1290	965	1167	
1 1/4-7	1.2500	1120	840	1815	1360	1646	
1 3/8-6	1.3750	1470	1100	2380	1780	2158	
1 1/2-6	1.500	1950	1460	3160	2370	2865	

Know the model number of the Stellar Cable Hoist being mounted. Use this model number whenever referring to the assembly or parts listing pages. The number is stamped on the name plate which is located on the front frame member.

Right and Left sides can be established by standing behind the truck frame and looking towards the front, or the direction of travel.

Truck Chassis Specifications

See the illustrations on pages 15-17 at the front of this manual for specific details.

Minimum Axle Rating:	Front: 18,000 lbs.
	Rear: 44,000 lbs. with walking beam type suspension
Frame Strength:	Total RBM per frame rail = 2,400,000 in-lbs. (both channels)
	Section Modulus (minimum) = 32 in ³ for 36,000 PSI steel
	Section Modulus (minimum) = 24 in ³ for 55,000 PSI steel
Important: If your truck chassis height exceeds the 45" dimension, or tire dimension is greater than 102", the O.R.X. or I.O.X. hoist should be considered.	

1. Thoroughly check the truck requirements to ensure proper clearance and frame strength before mounting the hoist. Note: The rear cab boundary is the rearmost unremovable protrusion behind the cab and above the chassis frame.
2. The CT, from the rear of the cab boundary to the center of the walking beam suspension, is shown in the table below:

<i>Relocate the rear axles as required. Stellar Autotarper must have 10" to 12" unobstructed space behind cab for installation.</i>	Model	Cab to Trunnion	
		<i>w/o Tarper</i>	<i>With Tarper</i>
	SI60-174	174 Inches	180 Inches
	SI60-182	182 Inches	188 Inches
	SI60-194	194 Inches	200 Inches

Step 1: Truck Frame Cut-Off

Measure and mark the truck frame as shown below. Use the dimensional drawings on the following pages to determine where to mark the first vertical cut on the frame rail. Measure assembled hoist to be sure that adequate room is available behind truck cab; between bumper and tires; and between fender and tires. This verifies that a measurement error has not been made either in the CT (Cab to Trunnion) or cut-off dimension. After double checking your measurements, step-cut the truck frame as shown below.

Cab Boundary

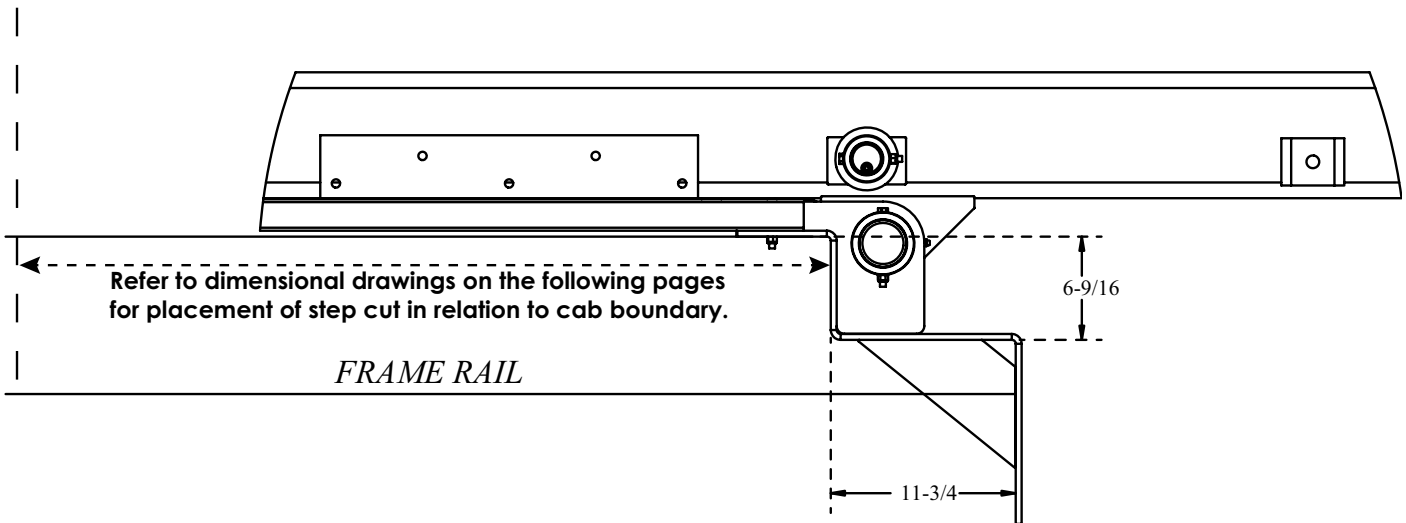

Dimensions: 174 Models

Forward Mount

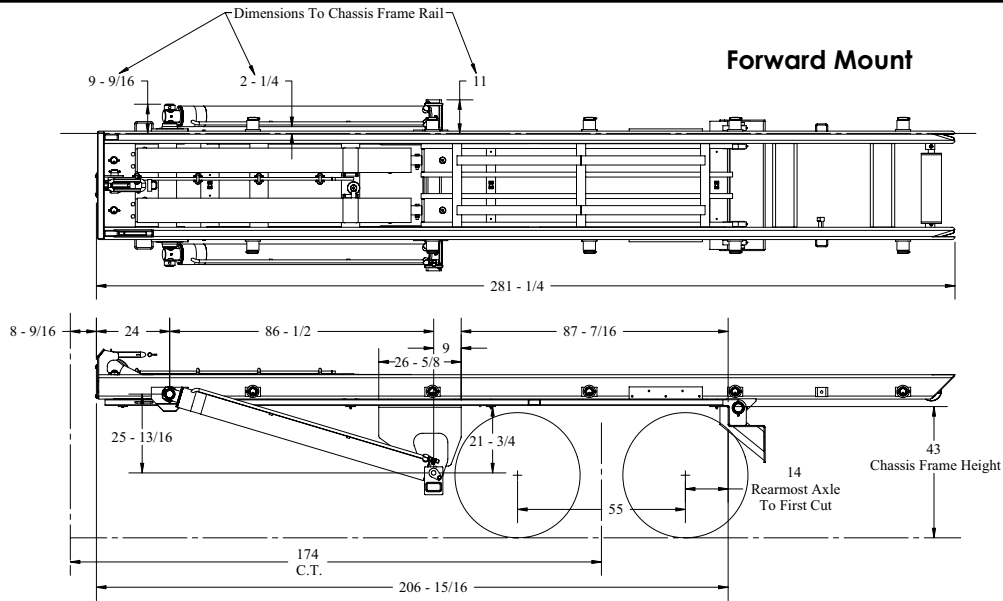

Reverse Mount

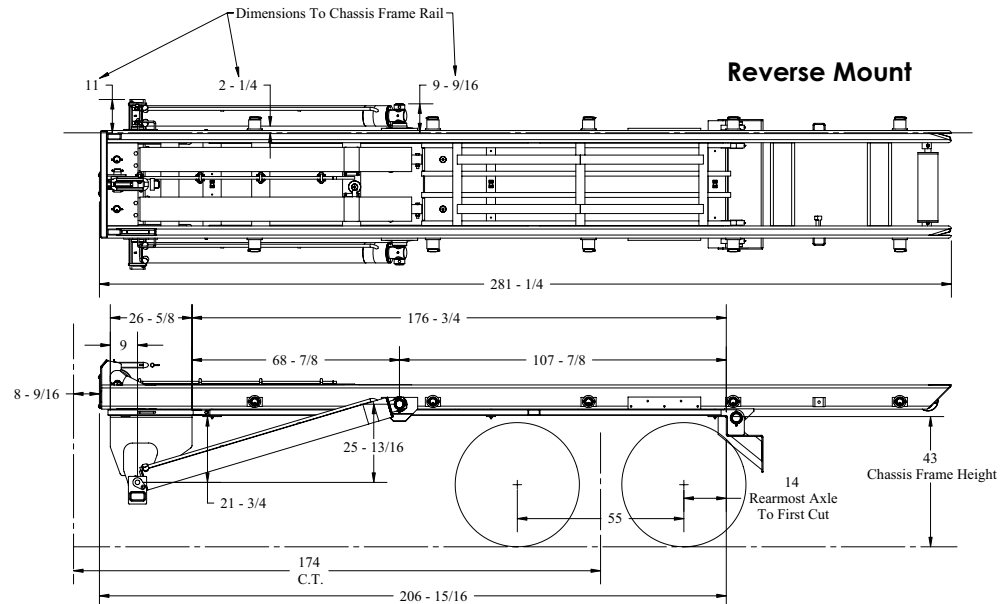

Telescopic Mount

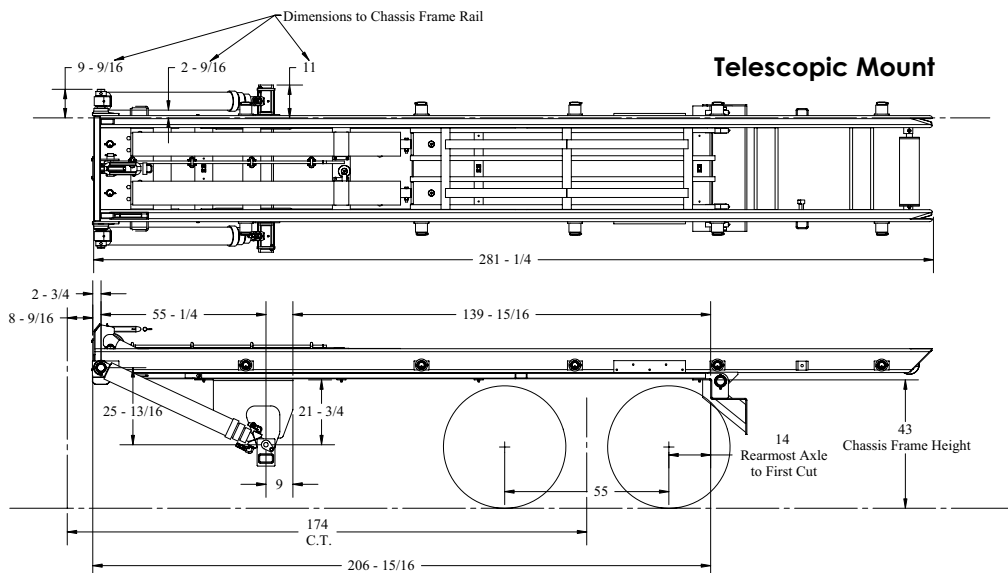

Dimensions: 182 Models

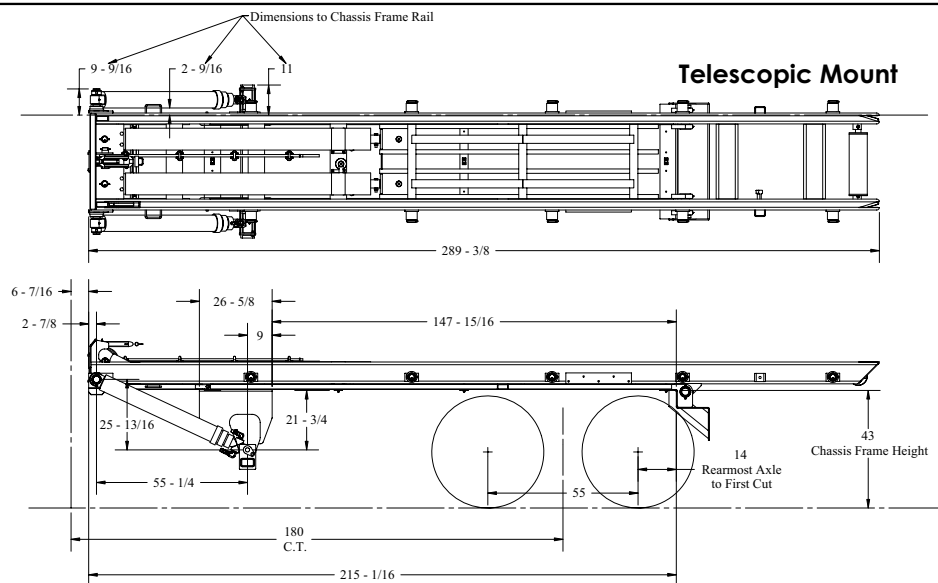
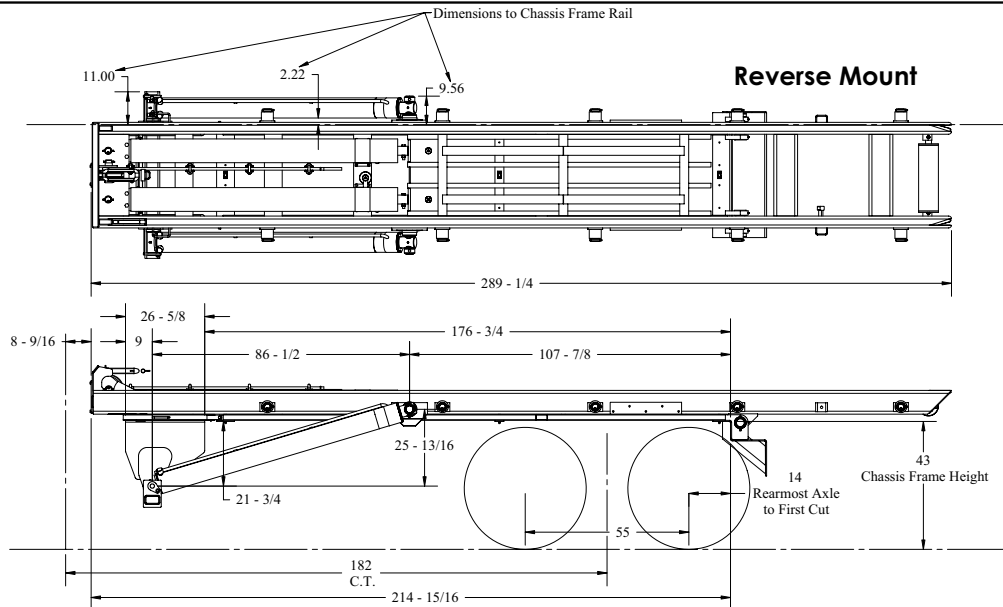
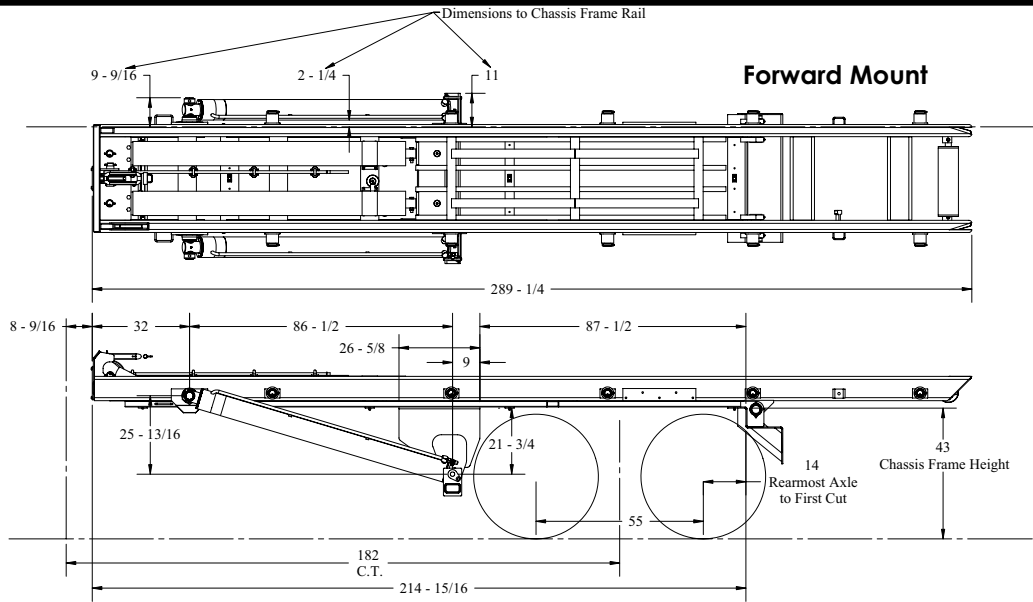

Dimensions: 194 Models

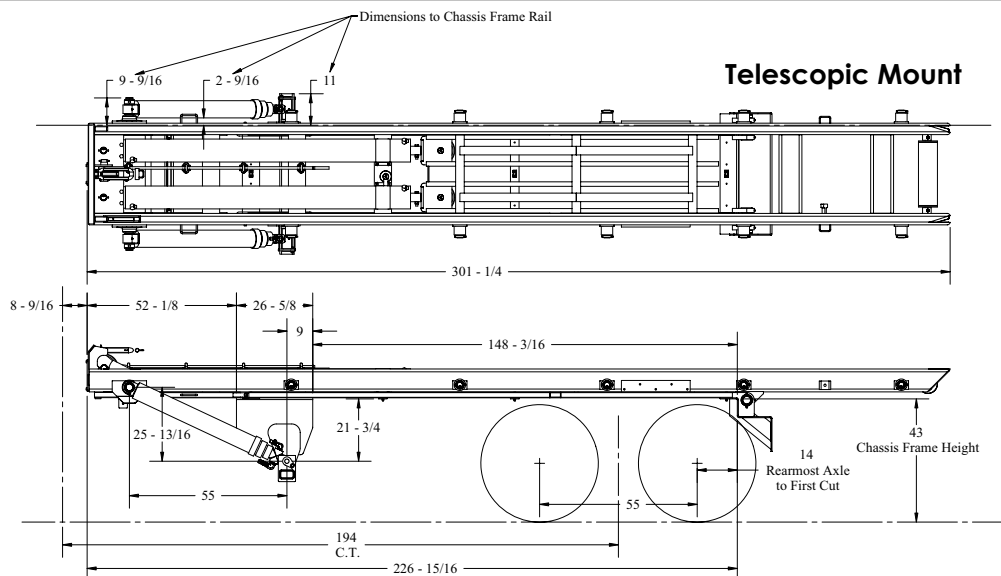
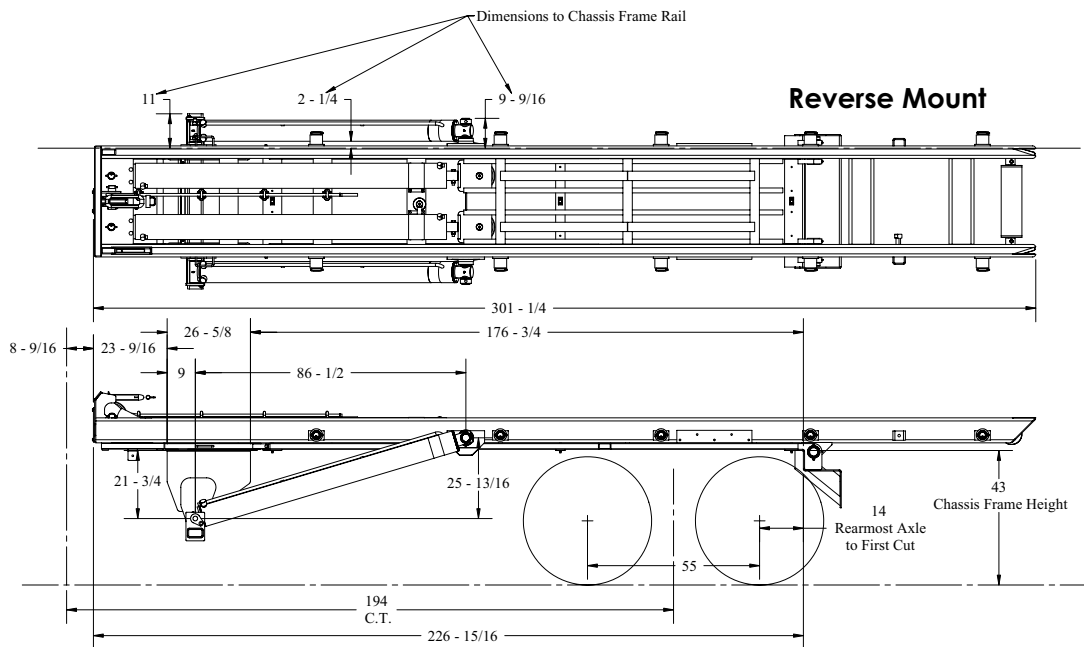
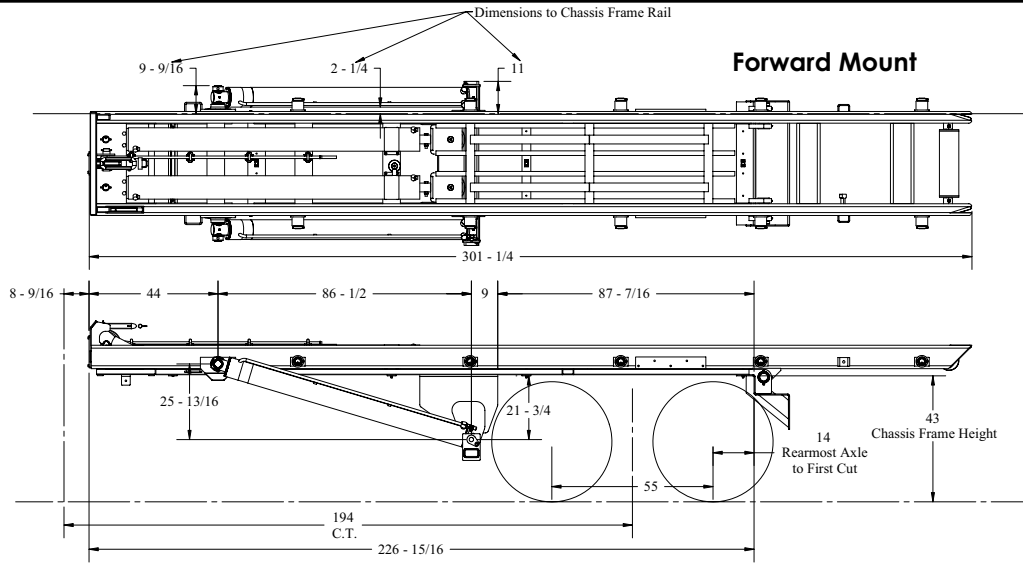

Step 2: Mount Hoist

Note: Refer to the illustrations on the previous pages for dimensions.

- A. Position the hoist sub-frame onto truck frame, aligning and squaring up with truck frame. Remove the tacked-on side gussets. Clamp the subframe to the truck frame and then heavily tack in place.
- B. Continue to fully weld the hoist rear apron to the truck frame. Weld a 100% $\frac{3}{8}$ " weld on both sides of truck frame to hoist sub-frame:

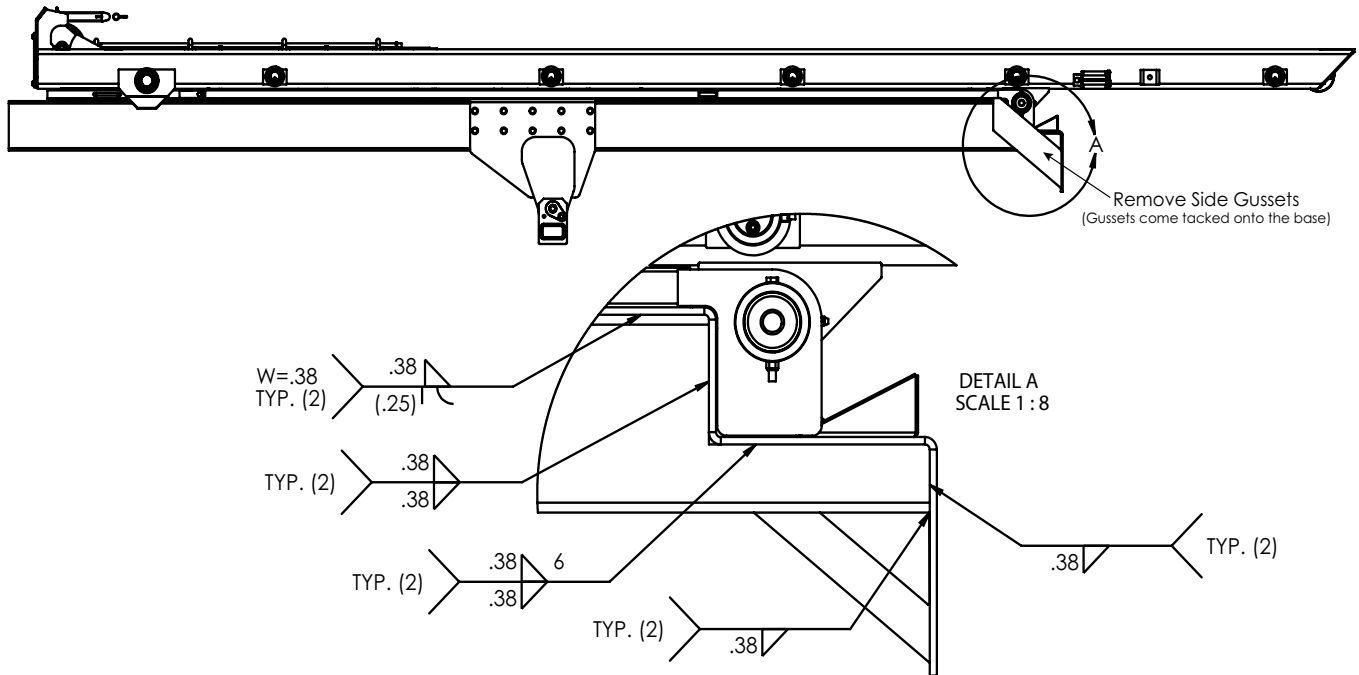

- C. Weld the gussets onto the hoist apron as shown below:

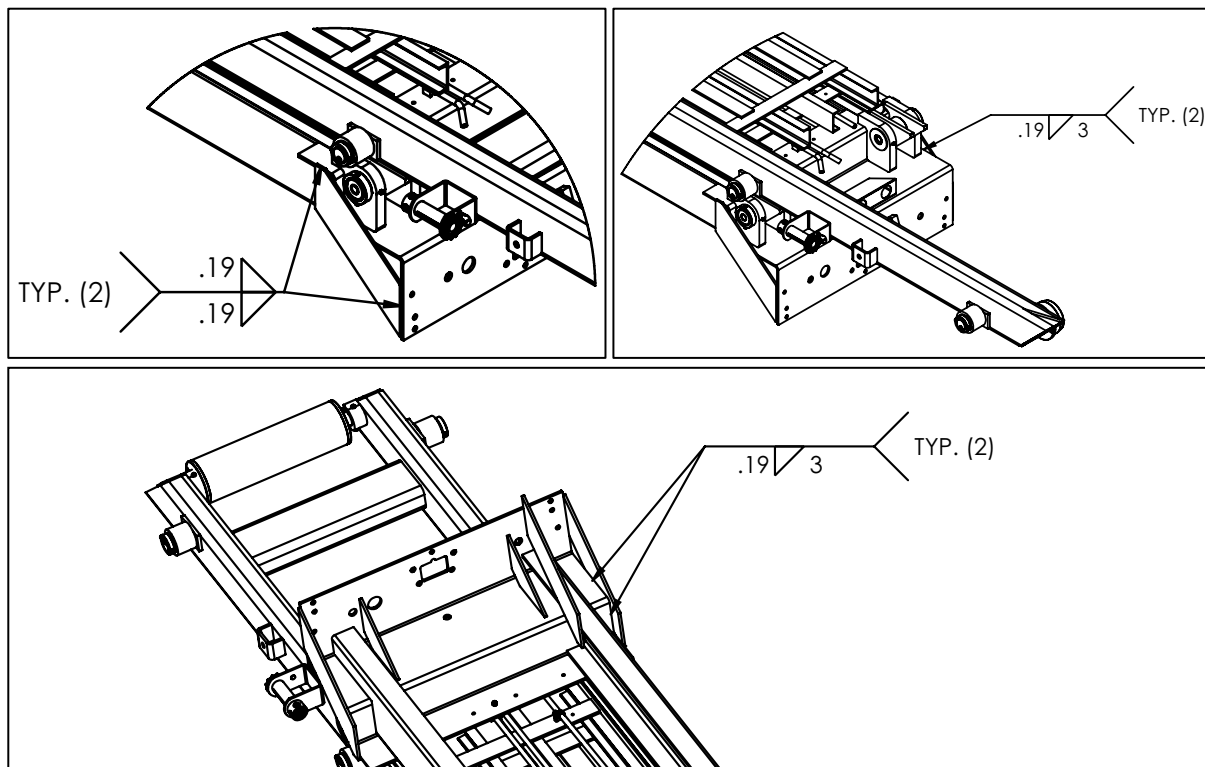

Step 3: Mount Lift Cylinders

- A. Check frame for bolts, rivets, etc. and clearance required (Refer to the previous pages) before placing the Lift Cylinder Weldment into place under the hoist sub-frame.
- B. Install the cylinder weldment cross tube.
- C. Install the Lift Cylinders and extend each cylinder rod 1/4". Check the shaft to cylinder dimension on both sides. Standard Lift Cylinders dimension should be 88 1/4" plus or minus 1/8". Telescopic Cylinder dimension should be 61-1/4" plus or minus 1/8". Be sure to install proper cylinder shaft hardware so that Lift Cylinders do not interfere with truck frame or bolts. The lift cylinders will precisely locate the lift cylinder weldments.

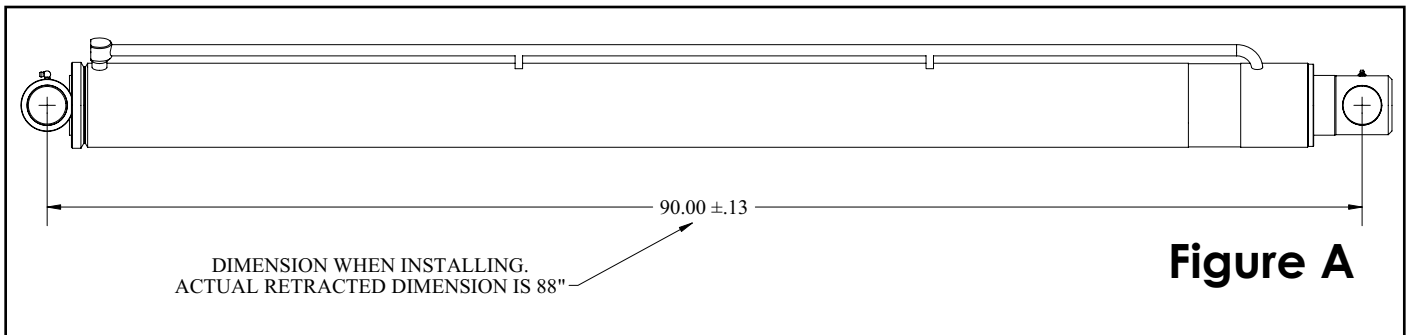

- D. Clamp the Lift Cylinder Weldment in place and drill ten (10) 11/16" diameter holes as per Figure B.
- E. Bolt the Lift Cylinder Weldment to the truck frame using the supplied hardware.

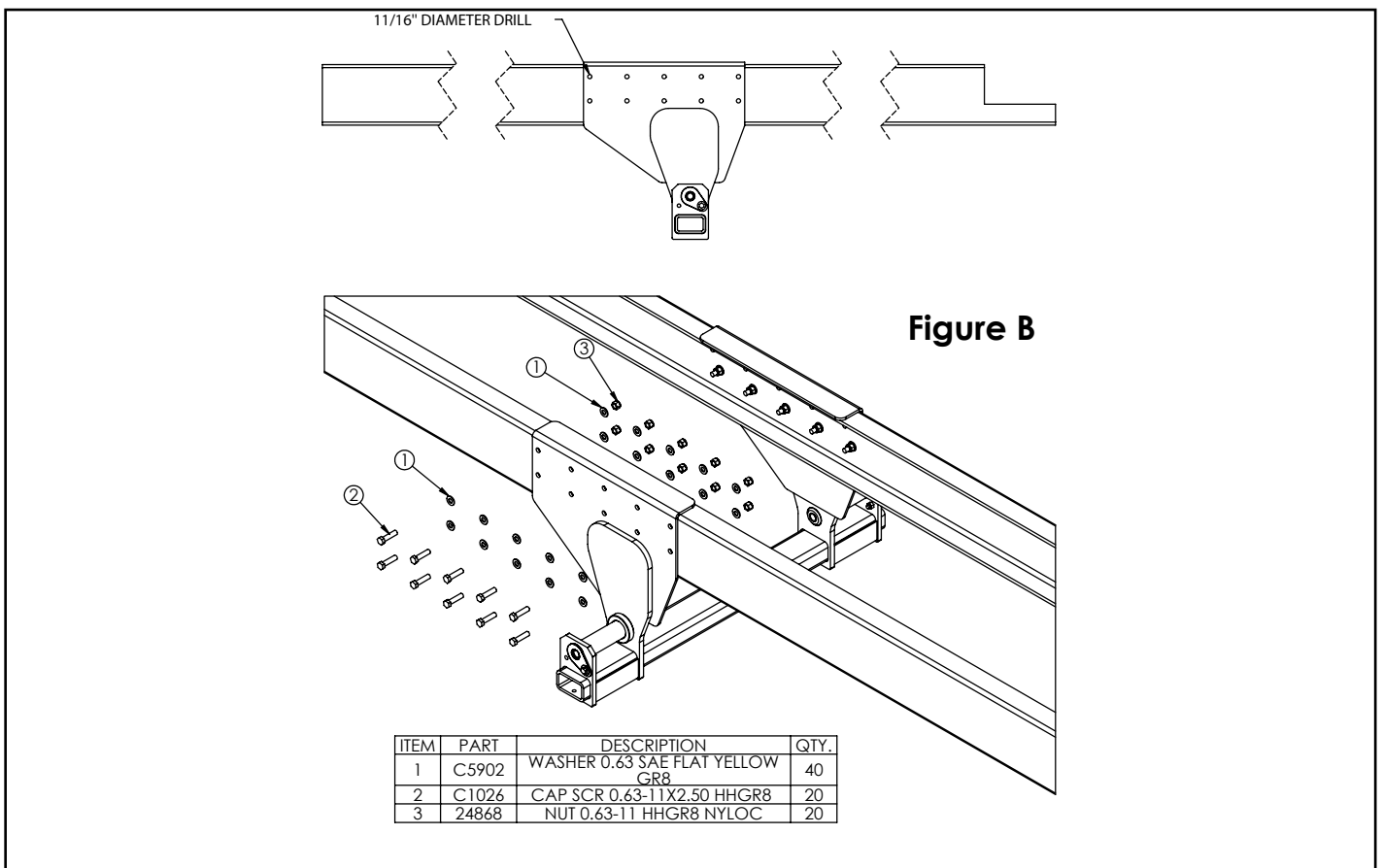

Mount Lift Cylinders Continued...

F. (FORWARD MOUNT ONLY) Weld the Lift Cylinder Weldment to the sub-frame as shown in Figure C. Remove any gap between the weldment and sub-frame before welding.

G. Make sure the cylinder cross tube is centered. Weld the cylinder cross tube. (See Figure B)

NOTE: Do not weld to truck frame. Welding anywhere on the truck frame in front of the rear spring shackle will likely void the truck manufacturers warranty.

H. Install the outside washers, collars, etc. to secure Lift Cylinders at rod and butt end. Refer to page 68 for mounting kit assembly drawing.

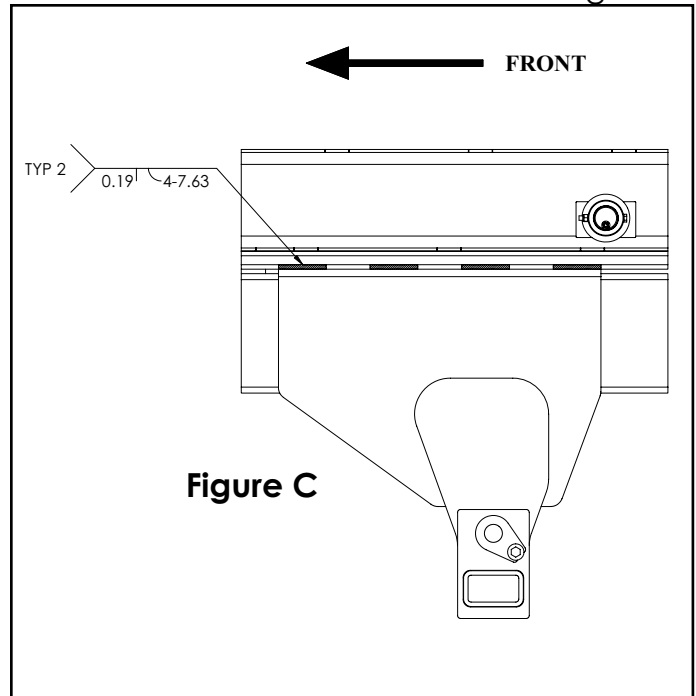

Step 4: Hydraulic Reservoir Installation

Note: See Chassis Mounted Parts and Reservoir Tank Assembly Drawings for details

1. Assemble valve, hoses, etc. to tank before mounting tank. Label hoses per illustration.
2. Position and clamp the Tank Mounting Bracket approximately 22" behind the rear of the cab boundary per illustration. Note: It may be necessary to relocate air tanks, fuel tanks, battery cases or any other accessories mounted in the area. Check both sides for clearance on hydraulic tank and toolbox mounting.
3. Drill six (6) 1/2" diameter holes as shown in illustration. Use six (6) 1/2 NC x 2-1/2" GD8 Cap Screws torqued to 80 ft. lbs. and six (6) 1/2 NC GD8 locknuts.
4. Install the Close Nipple, Ball Valve, and Hose Barb onto the Tank Assembly.
5. Remove the Tank Assembly and drill 3/8" diameter holes on the marks.
6. Re-Install the tank and tighten the set screws into the drilled holes. Tighten the jam nuts.
7. Note: Petro-Canada Hydrex 32 (ISO 32) hydraulic oil is recommended.

Step 5: Base Clamp Installation

Before proceeding any further, it is necessary to raise the hoist and set it down on the hoist props.

1. Position the L-shaped base clamp between the sub-frame and truck frame as shown below.
2. Install the base clamp as shown below.
3. **Do not weld to truck frame.**

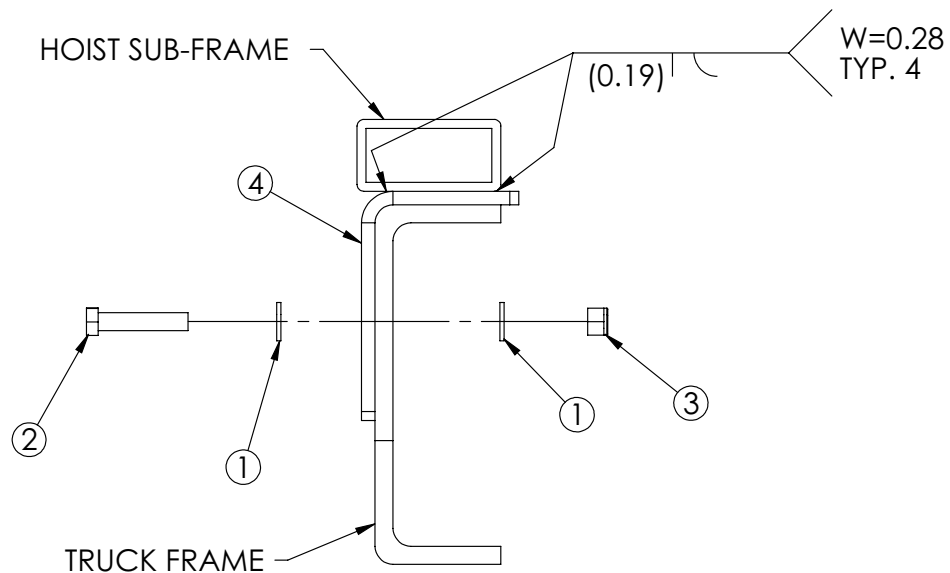
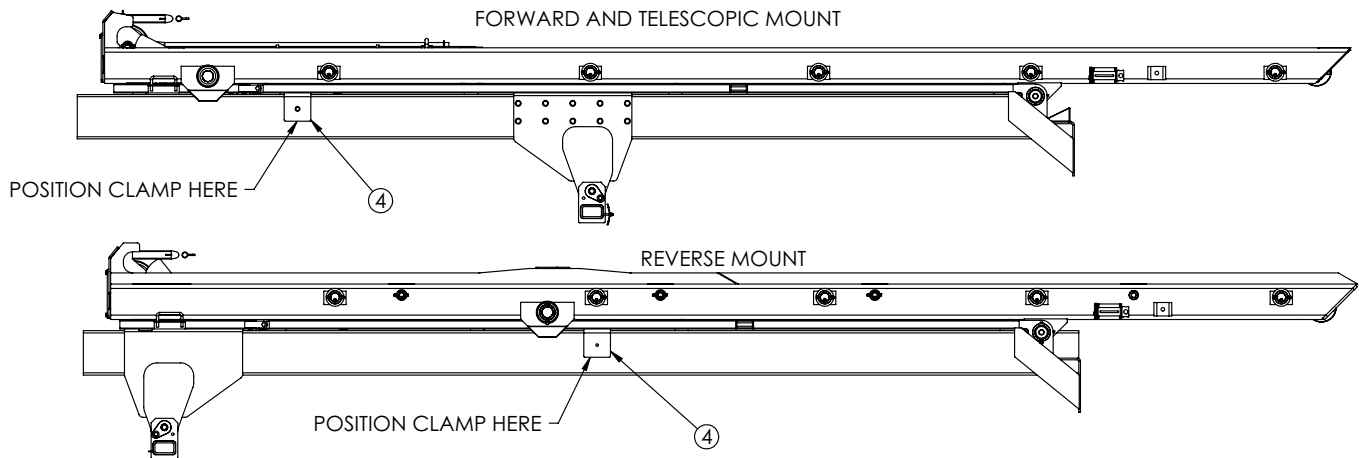

ITEM	PART	DESCRIPTION	QTY.
1	D0790	WASHER 0.50 SAE FLAT YELLOW GR8	4
2	10662	CAP SCR 0.50-13X2.50 HHGR8	2
3	5468	NUT 0.50-13 HHGR8 NYLOC	2
4	72358	PLATE SUBFRAME CLAMP SI60	2

Optional Extender Clamp Install for 182/194 Models

The optional extender clamp is for installation on the longer 182 and 194 cable hoists:

1. Position the L-shaped extender clamp between the sub-frame and truck frame as shown below.
2. Install the extender clamp as shown below.
3. **Do not weld to truck frame.**

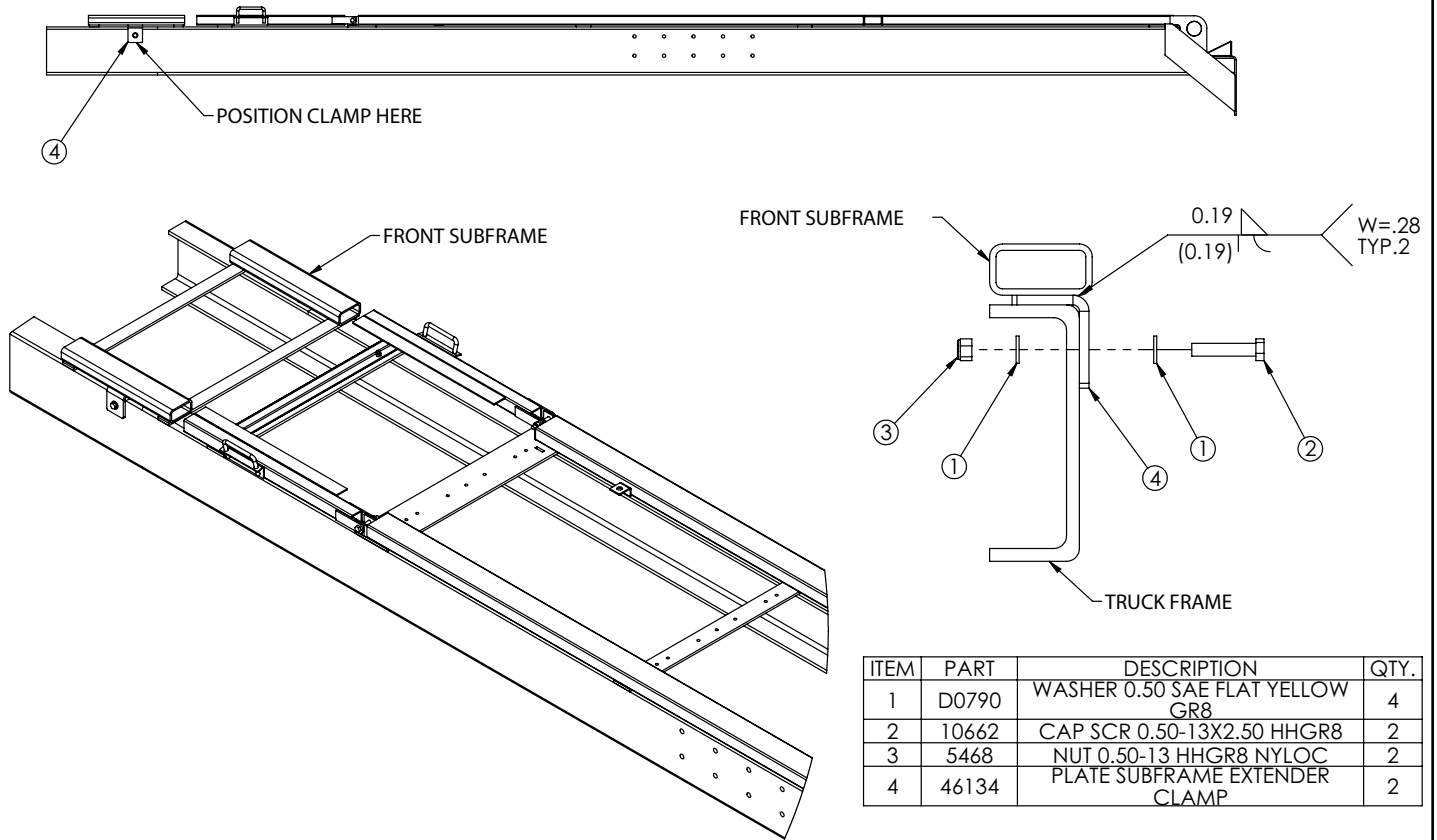

ITEM	PART	DESCRIPTION	QTY.
1	D0790	WASHER 0.50 SAE FLAT YELLOW GR8	4
2	10662	CAP SCR 0.50-13X2.50 HHGR8	2
3	5468	NUT 0.50-13 HHGR8 NYLOC	2
4	46134	PLATE SUBFRAME EXTENDER CLAMP	2

Step 6: Hydraulic Plumbing Installation

Clean all hydraulic components and keep all hoses, tubes, valves, and fittings capped until they are installed. Use pipe sealant on pipe thread joints only. (Do not use teflon tape).

1. Install fittings and hoses as shown in parts illustration.
2. Note single stage Lift Cylinder plumbing and Telescopic Cylinder plumbing are different. See hydraulics schematic/drawing for details.

Step 7: Hydraulic Relief Pressure Setting

1. Locate the pressure gauge facing front of truck.
2. Loosen Jam Nut.
3. Using allen wrench, adjust to proper pressure. See **Chapter 4: Specifications** for pressure specifications.
4. Tighten Jam Nut, holding adjustment screw in position.
5. Test unit for proper operation, readjust to correct pressure if needed.
6. Retest unit checking leaks and proper operation.

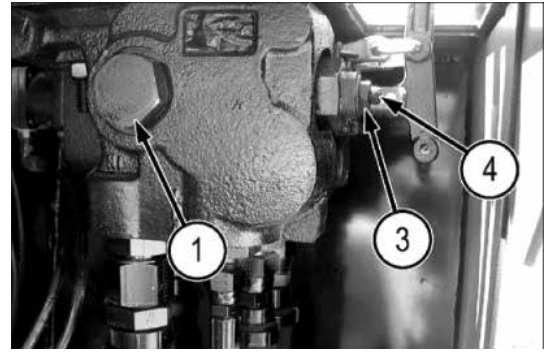

Step 8: Cable Control Installation

In Cab Installation

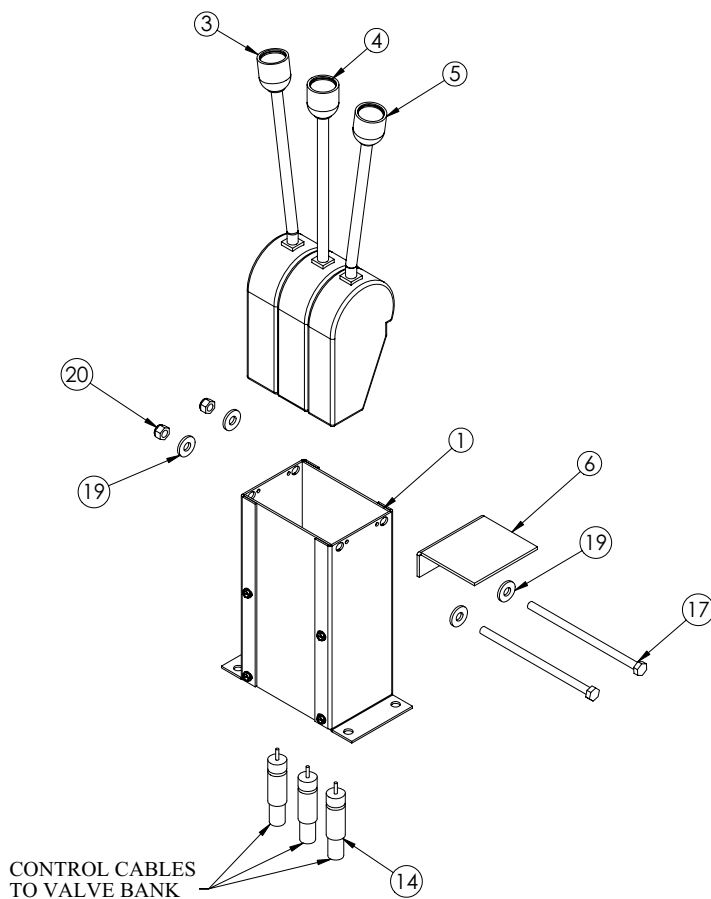

	2 SECTION	3 SECTION
96 INCH	PN 55534	PN 54746
144 INCH	PN 55540	PN 54747
192 INCH	PN 55541	PN 54748

	2 SECTION	3 SECTION
96 INCH	PN 55534	PN 54746
144 INCH	PN 55540	PN 54747
192 INCH	PN 55541	PN 54748

At Valve Installation

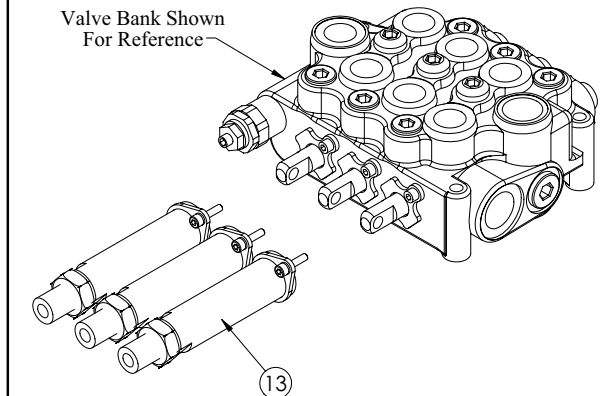

ITEM	PART	DESCRIPTION	QTY.
1	38351	VALVE CTRL CONSOLE 3LEVER RVC (3 Section Only)	1
1	37470	VALVE CTRL CONSOLE 2LEVER RVC (2 Section Only)	1
3	37475	CONTROLLER CTR LOCK LEFT BEND	1
4	37476	CONTROLLER CTR LOCK NO BEND (3 Section Only)	1
5	37474	CONTROLLER CTR LOCK RIGHT BEND	1
6	25933	BRKT CONTROLLER DECAL	1
13	37469	CABLE CONN. KIT FOR VD8A/VDM8	2/3
14	37471	CONTROL CABLE 96 IN WESCON	2/3
14	37472	CONTROL CABLE 144 IN WESCON	2/3
14	37473	CONTROL CABLE 192 IN WESCON	2/3
17	20057	CAP SCR 0.31-18X6.50 HHGR5 (3 Section Only)	2
17	0491	CAP SCR 0.31-18X4.00 HHGR5 (2 Section Only)	2
19	0343	WASHER 0.31 USS FLAT ZINC	4
20	0342	NUT 0.31-18 HHGR5 NYLOC	2

Step 9: Air Control Installation

ITEM	PART	DESCRIPTION	QTY.
1	75868	CONTROLLER ASM 3 SECT AIR PED	1
2	D1810	TBE AIR SAEJ844 TYPE A .25 (RM)	4
3	45333	FTG .125NPT MALE / .25 TUBE QR KPAC	2
4	45687	FTG ADAPT PTC-MNPT 90° 1/4-1/8 NI-PLATED BRASS	7
5	35211	PTO AIR REGULATOR 378414	1
6	C5934	NIPPLE 0.25XCLOSE BLK	1
7	C1065	BUSHING 0.50X0.25 BLK	1
8	25940	VB 2-SECTION VDM8 W/AIR ACTUATORS	1

PTO SWITCH

**AIR - 62976 (Standard)
ELECTRIC* - PN 63142 (Optional)**

* Note: When using PN 63142, an adapter plate (PN 63143) is required.

HOSE	FUNCTION
BLACK	EXHAUST
SILVER	SUPPLY
BLUE	HOIST LOWER
GREEN	HOIST RAISE
ORANGE	CABLE UNLOAD
WHITE	CABLE LOAD
RED	PTO
YELLOW*	TAIL RET/EXT
YELLOW*	AUX IN/OUT

*When Used with 3rd Section

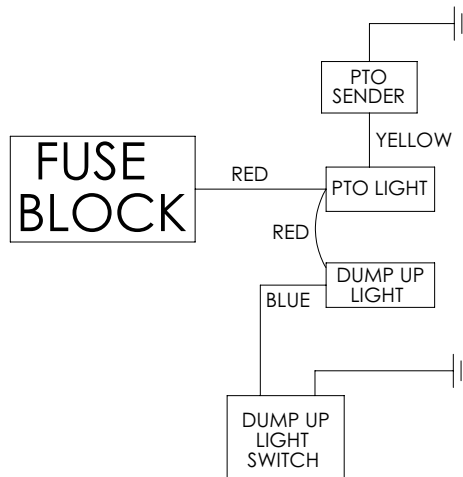
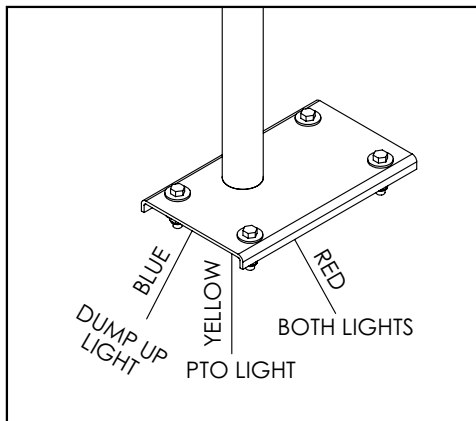
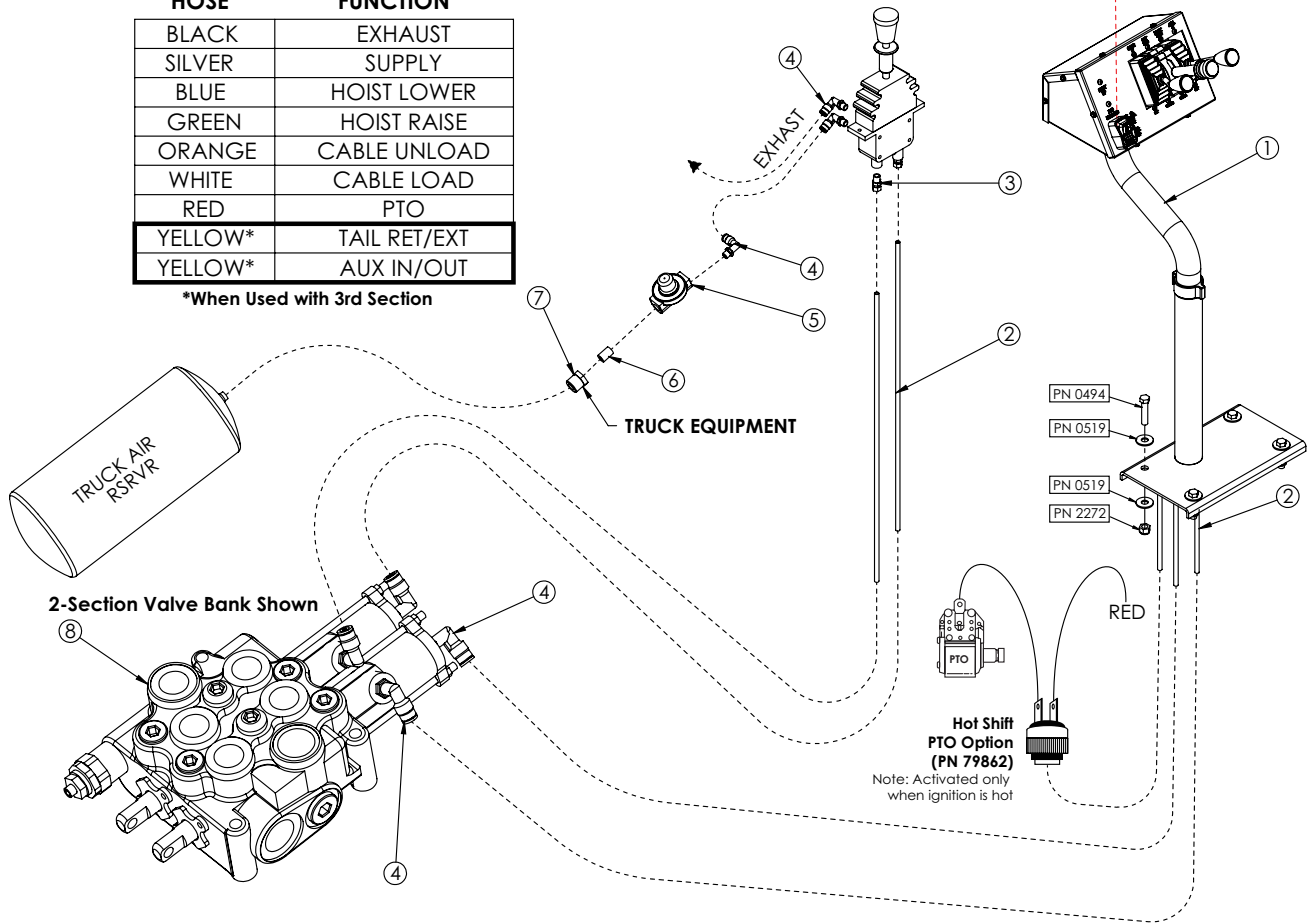

NOTE: THE HOIST UP LIGHT WILL ONLY BE ACTIVATED WHEN THE IGNITION IS HOT. IT IS RECOMMENDED TO TAP INTO THE PTO LIGHT POWERSOURCE WHEN WIRING.

Optional Controller Bracket

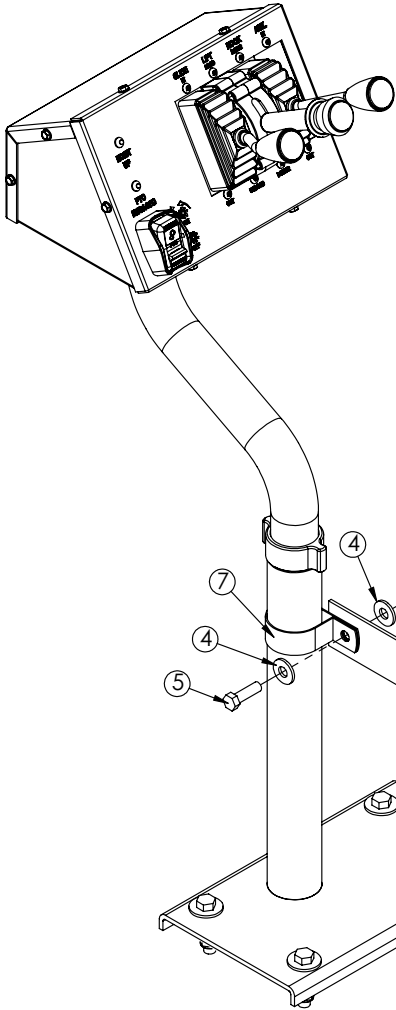

If the chassis floor is too thin to provide sturdy support for the controller pedestal, use the optional support hardware:

ITEM	PART	DESCRIPTION	QTY.
5	0335	CAP SCR 0.38-16X1.25 HHGR5	2
6	0347	NUT 0.38-16 HHGR5 NYLOC	2
7	CLAMP	CLAMP 2.00 BLK VINYL	1
8	BRACKET	BRKT 10GAX2.00X24.00	1

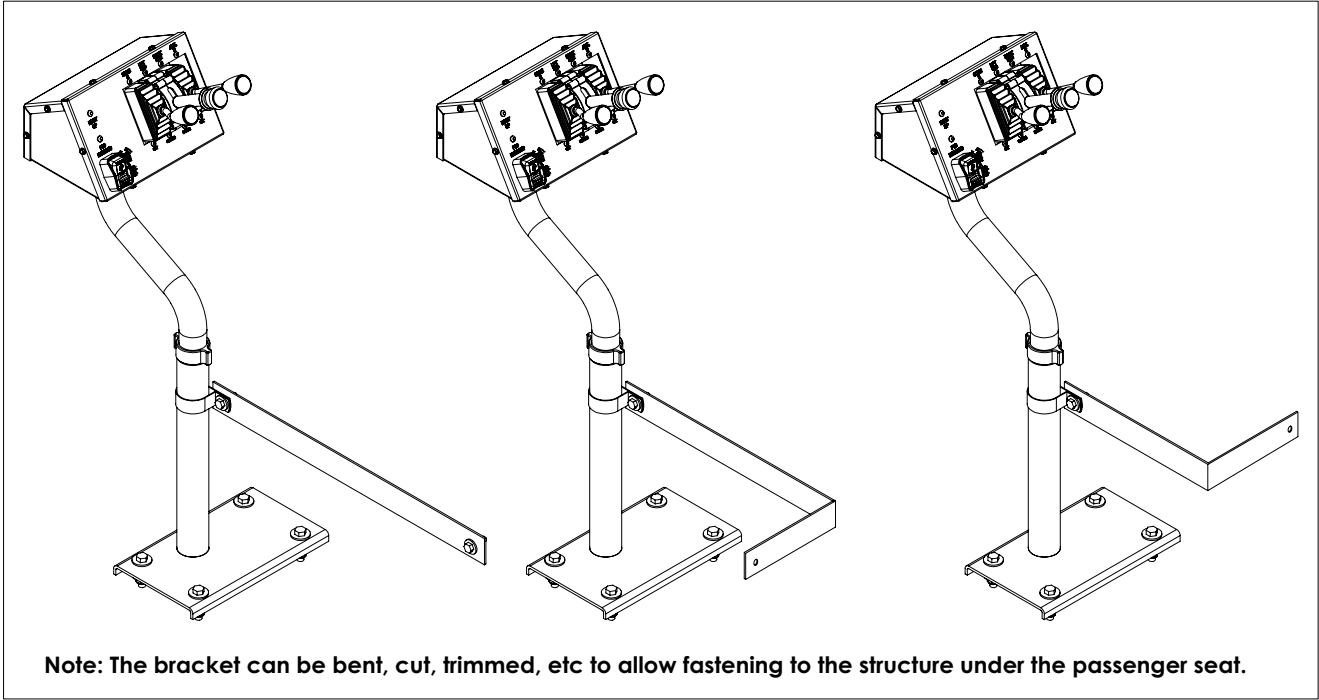

Step 10: Bumper Installation

Lighted Bumper Installation

1. Align the holes in the lighted bumper with the holes in the hoist sub-frame apron.
2. Install six (6) 5/8NC x 1-3/4" GD.8 Cap Screws, twelve (12) Flat Washers, and six (6) Hex Nuts. Torque to specifications.
3. Install wiring harness P/N 38056 through the access hole.
4. Install the bumper lights as shown on parts pages 59-60.
5. Connect the female end of wiring harness P/N 38056 to the male end of wiring harness P/N 40310 as shown on page 42.
6. Check all light functions. Important: The back-up alarm should sound when the back-up lights are on.

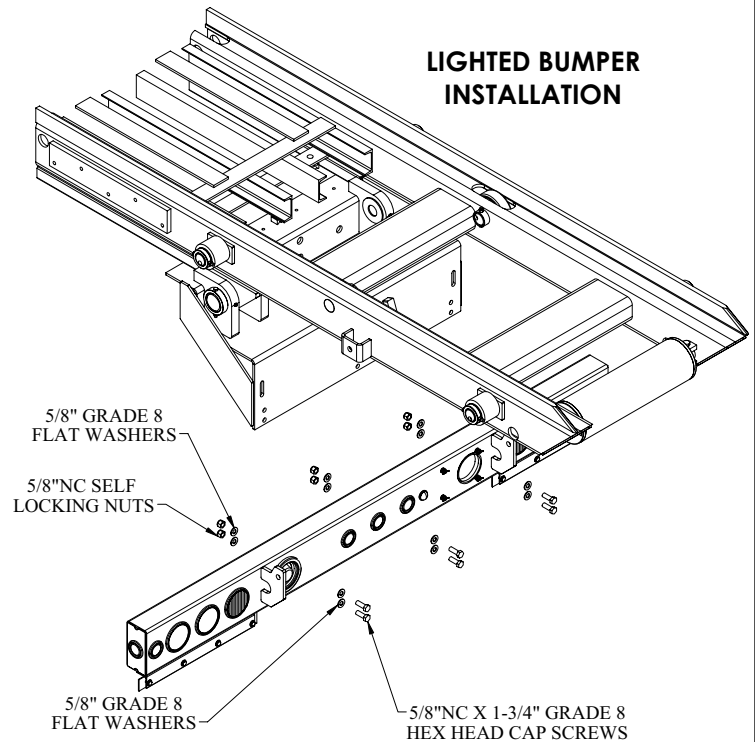

PINTLE BUMPER INSTALLATION

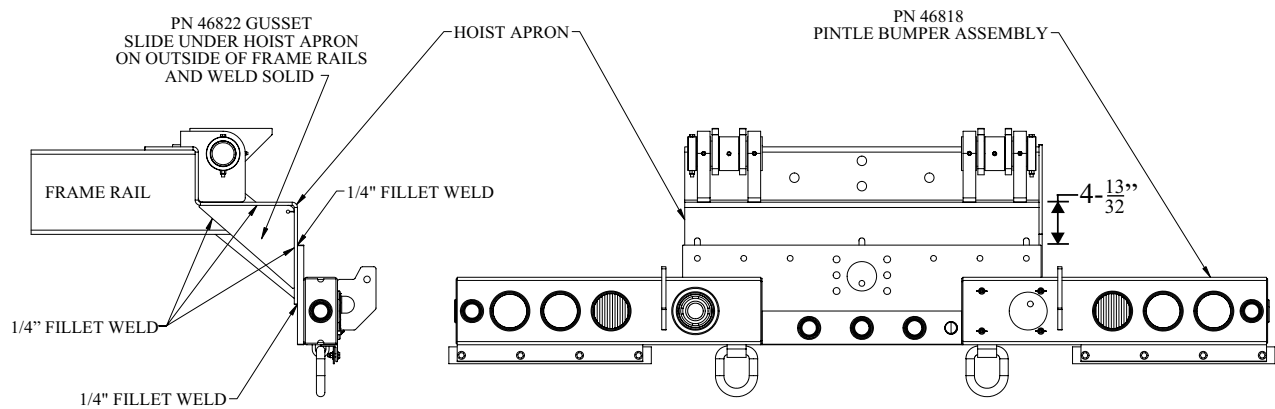

Pintle Bumper Installation

1. Position the bumper weldment over the hoist apron and center.
2. Make sure bumper is level and tack weld into position.
3. Match drill all fender and pintle mounting holes through the hoist apron.
4. Weld bumper to apron per weld call-out shown.
5. Position and weld the reinforcement gussets as shown.
6. Check all light functions. Important: The back-up alarm should sound when the back-up lights are on.

Bumper Installation Continued...

I.C.C. Bumper Installation

1. Connect the bumper weldment to the hoist with two (2) 3/4NC x 4-1/2" Cap Screws, Spacers, Flat Washers and Self-Locking Nuts. It may be necessary to use Flat Washers between the bumper uprights and the hoist frame.
2. Connect the lower links between the pivot on the lighted bumper and the ICC bumper. Use a 3/4NC x 2-1/2" GD.5 Cap Screw, Spacer, Flat Washer and Self Locking Nut to attach each link to the lighted bumper. Use a 3/4NC x 4-1/2" GD.5 Cap Screw, Spacer, Flat Washer, and Self Locking Nut to connect each link to the ICC bumper.
3. Torque nuts to specifications.
4. The ICC Bumper should fold up against or near the tail of the hoist as the unit is raised to the full-up position. If the ICC Bumper does not fold correctly, it will be necessary to add flat washers between the lighted bumper and the sub-frame apron. To tuck the ICC Bumper closer to the hoist frame, the flat washers must be installed on the upper lighted bumper mounting bolts. If the ICC contacts the hoist before the unit is completely raised, the flat washers should be installed on the lower lighted bumper mounting bolts.

ICC Bumper Installation (I.O.X.)

1. This ICC bumper is mounted in the same manner as the OR or IO ICC Bumper.

Pintle ICC Bumper Installation (See Illustration on Next Page)

1. Modify PN 46818 Pintle Bumper by welding PN 51629 collars to ICC bumper brackets.
2. Match drill holes in ICC bumper brackets to holes in PN 51629 collars 1.06 DIA.
3. Drill one side of PN 45813 Flat Link to 1.06" DIA.
4. Bolt PN 45814 Standard ICC bumper to existing brackets on the sides of the hoist frame.
5. Swing up ICC Bumper and locate where PN 48159 Bushings will be welded. Weld bushing to the under side of hoist frame on both sides. Make sure cross-drilled holes in bushings are on the outside of the hoist frame.
6. Swing bumper down and weld PN 51628 Stop to the top of the ICC Pivot Tube. (See Illustration)
7. Lock ICC Bumper in the down position using PN 45311 Pin and PN 45216 Lock Pin.
8. Bumper must be pinned down except when pulling a pup trailer. Pin bumper up when pup trailer is attached to eliminate any possible damage to bumper or trailer tongue.

Heavy Duty ICC Bumper Installation

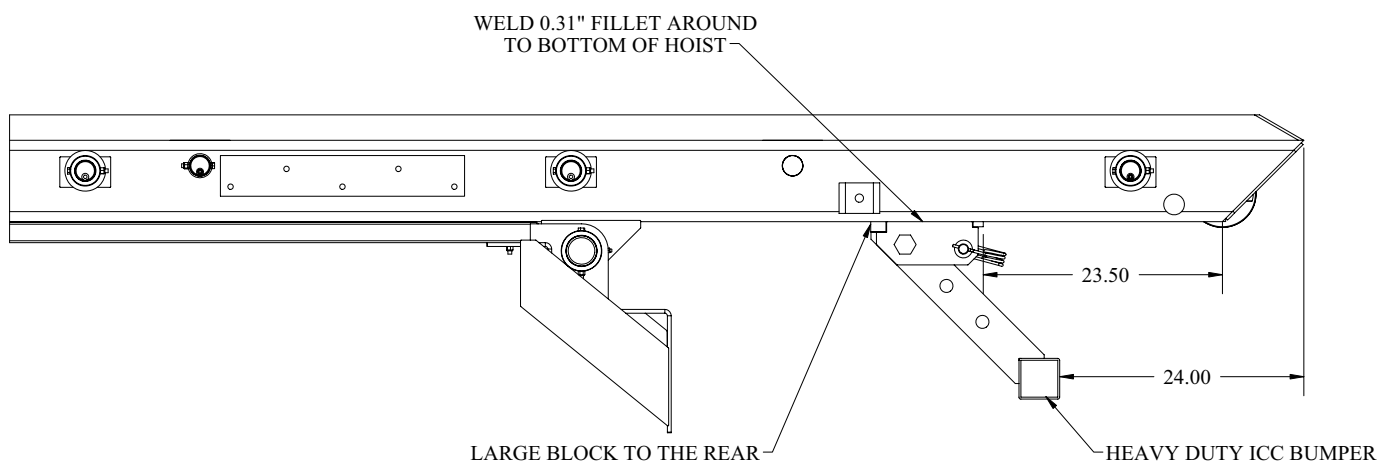

Step 11: Hoist Up Light Installation

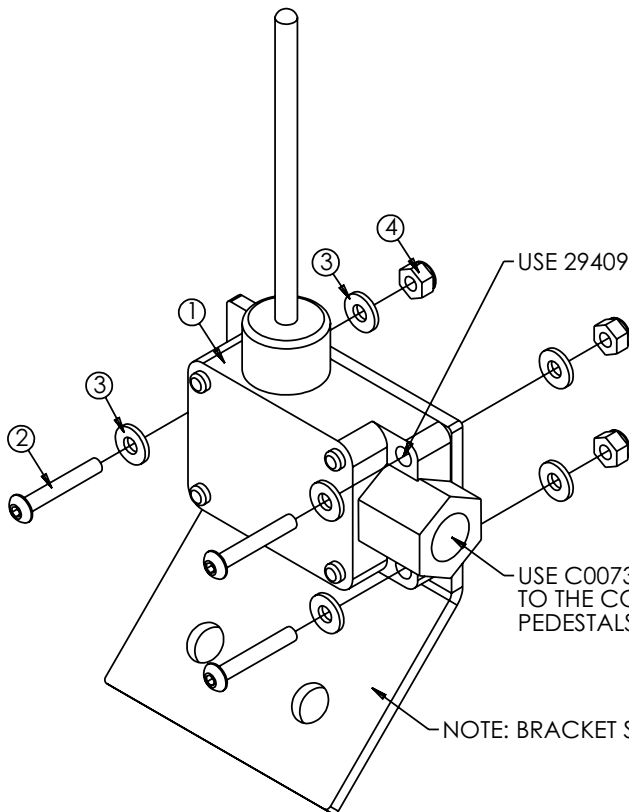
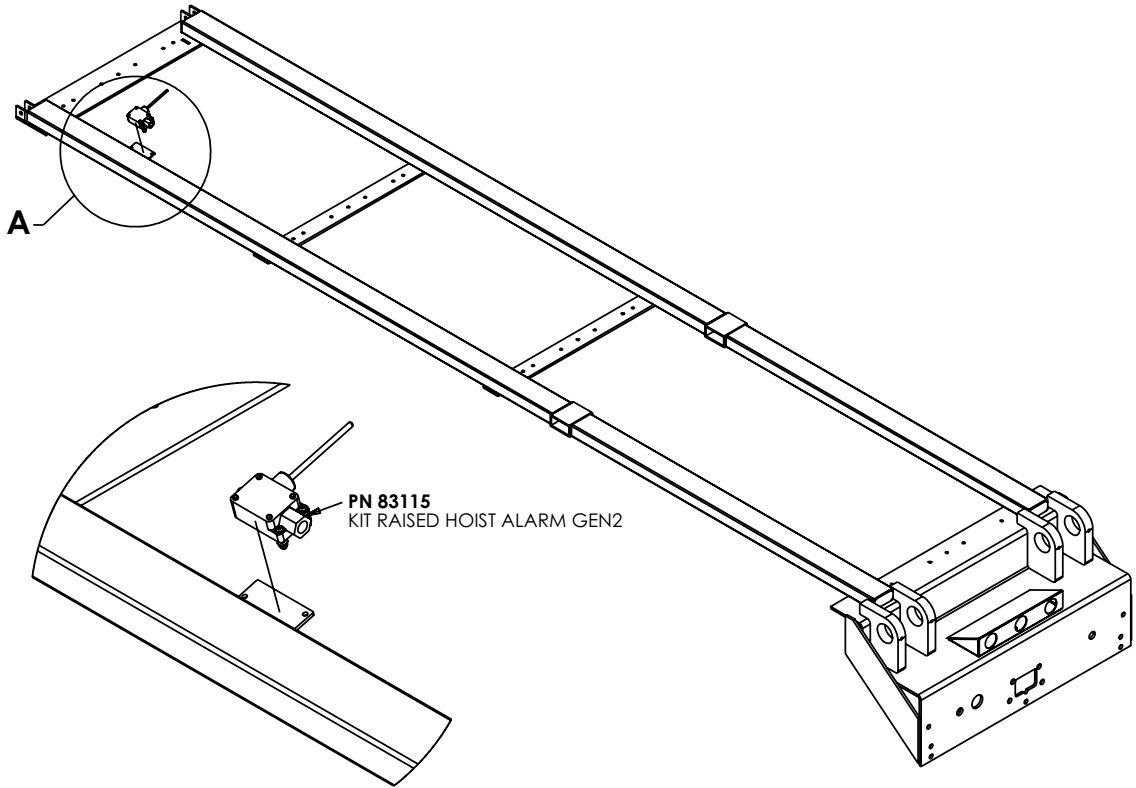

USE 29409 TO GROUND BLACK WIRE

PN 83115

ITEM	PART	DESCRIPTION	QTY.
1	45907	SWITCH REMOTE KP60	1
2	30472	CAP SCR #10-24X1.25 BTNHD SS	3
3	D0178	WASHER #10 SAE FLAT	6
4	26034	NUT #10-24 HH NYLOC	3

ITEMS NOT SHOWN:

C0073 - TERML 16-14 BLUE BUTT WATER TIGHT X 1
 29409 - TERML 12-10X.31 RING X 1

USE C0073 TO CONNECT RED WIRE TO THE CONTROLLER ASSEMBLY
 PEDESTALS (BLUE) DUMP UP LIGHT WIRE

NOTE: BRACKET SHOWN AS REFERENCE ONLY

Step 12a: Fender Installation - Steel Tandem/Tri-Axle

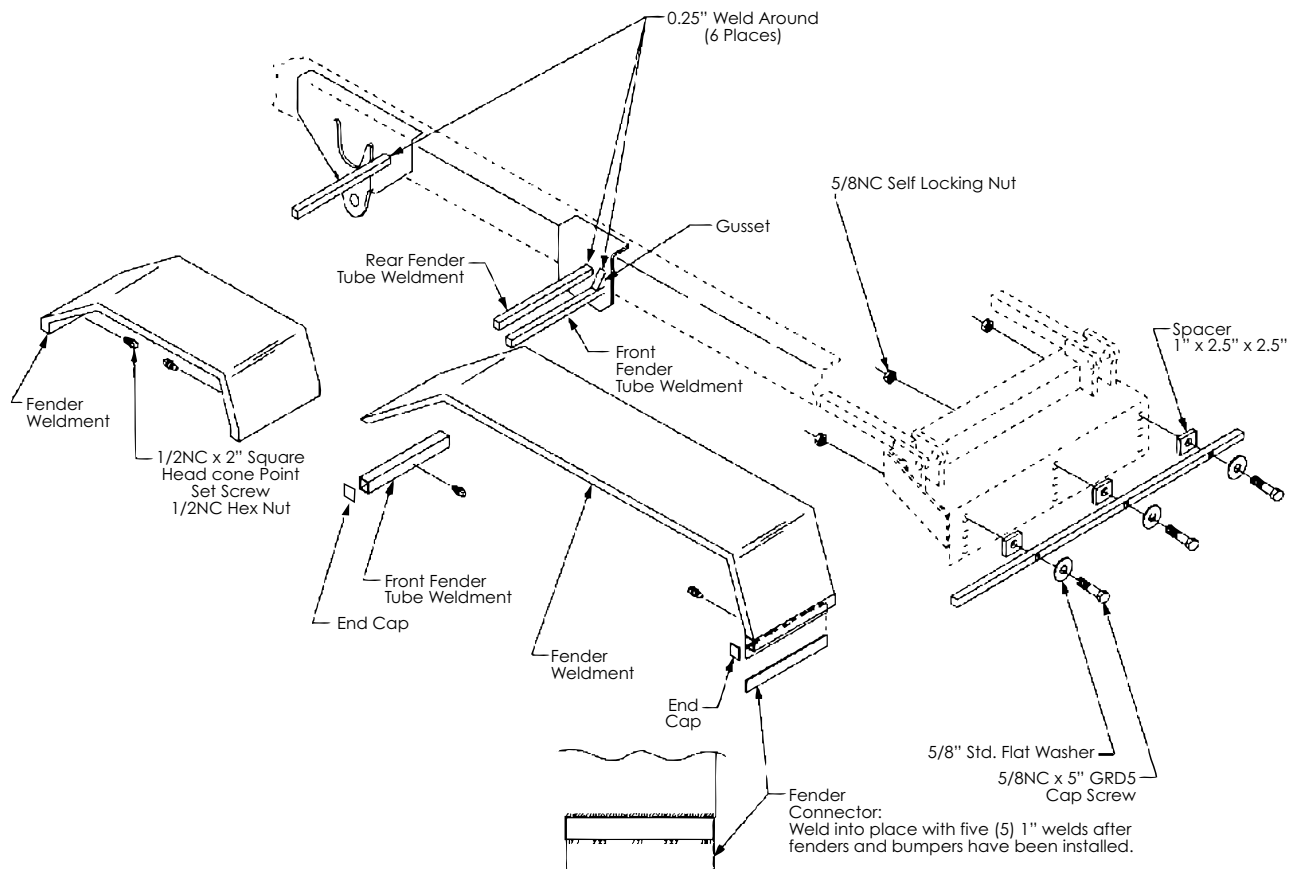
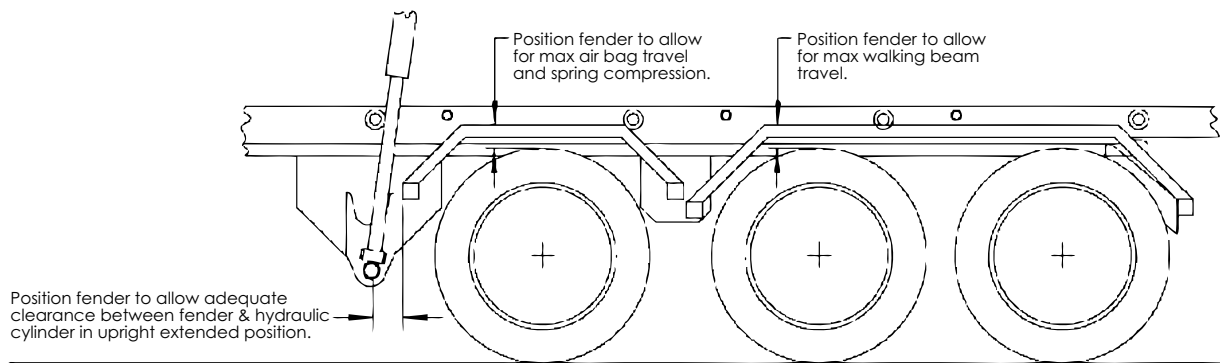
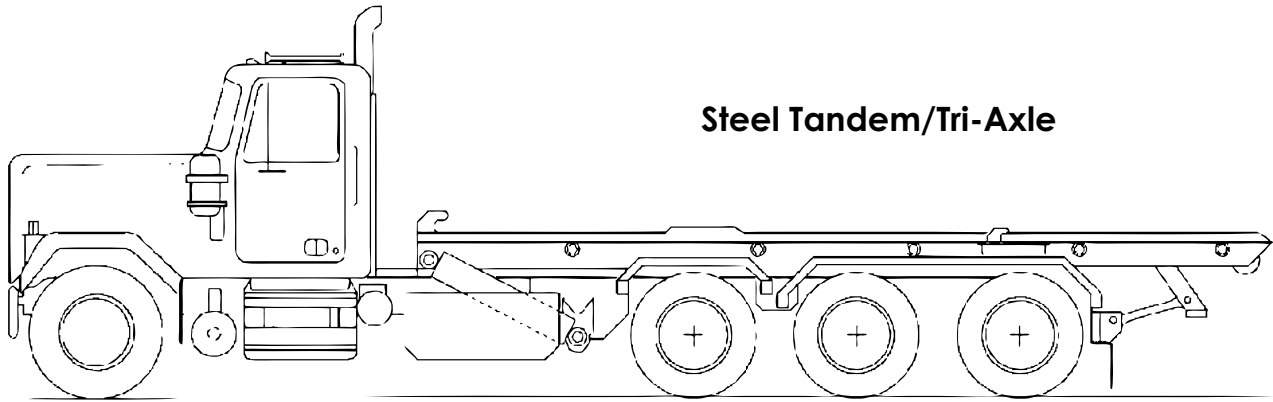

Step 12b: Fender Installation - Plastic Tandem/Tri-Axle

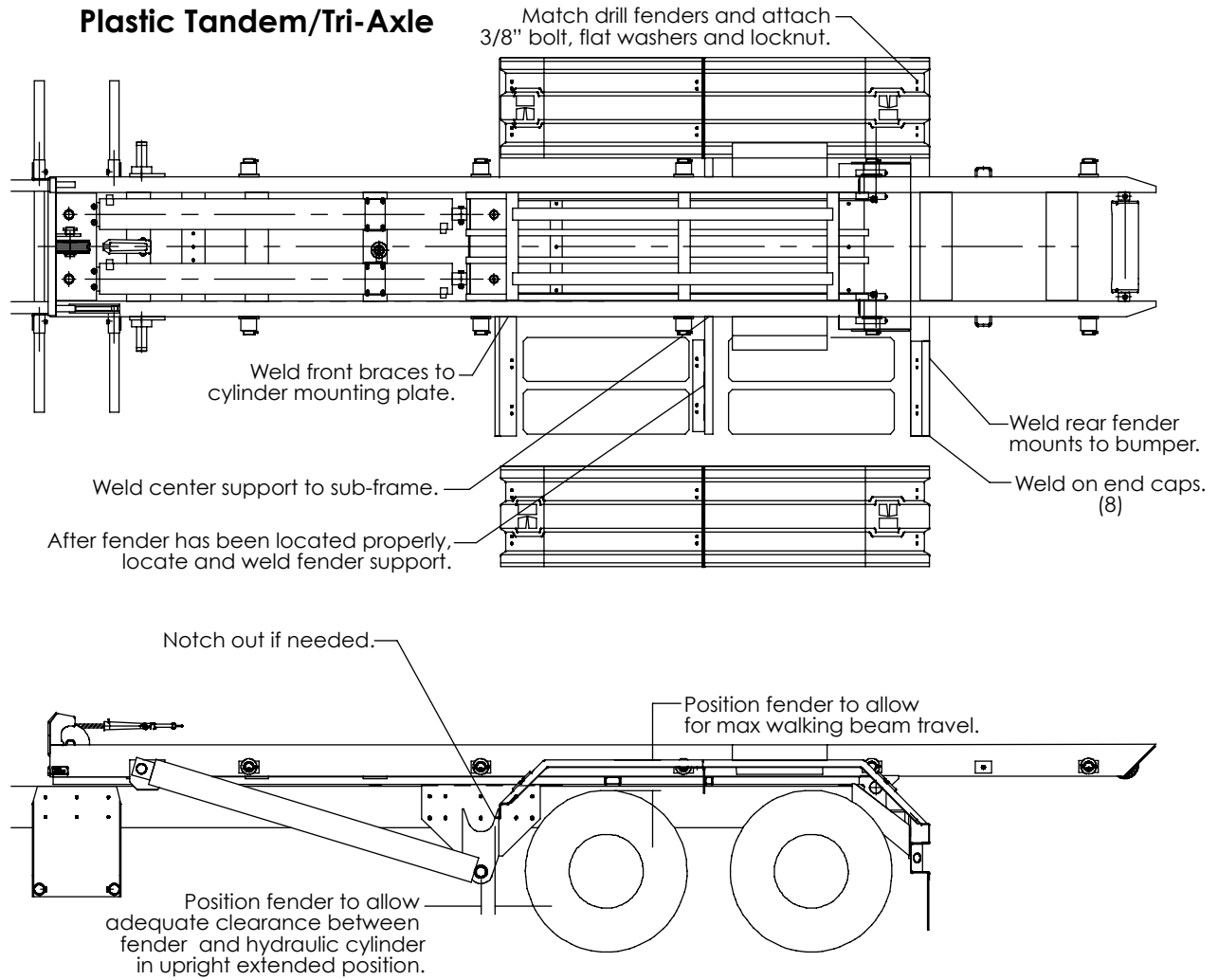

Step 13: Mid-Body Light Installation

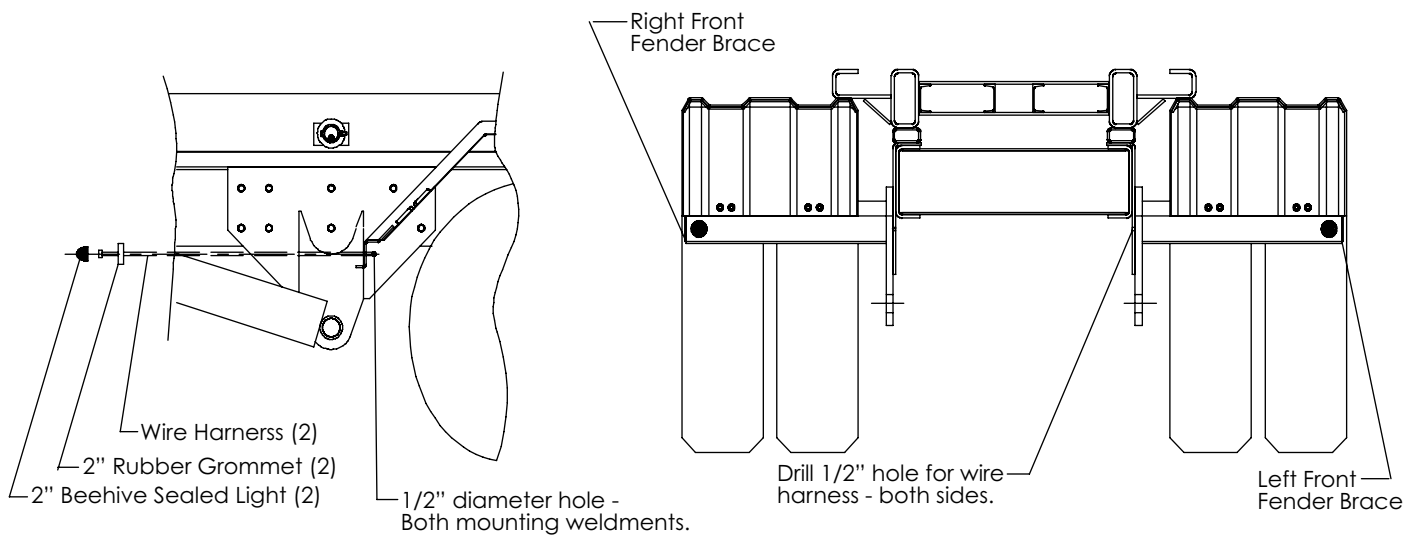

Step 14a: Removable Stop Installation

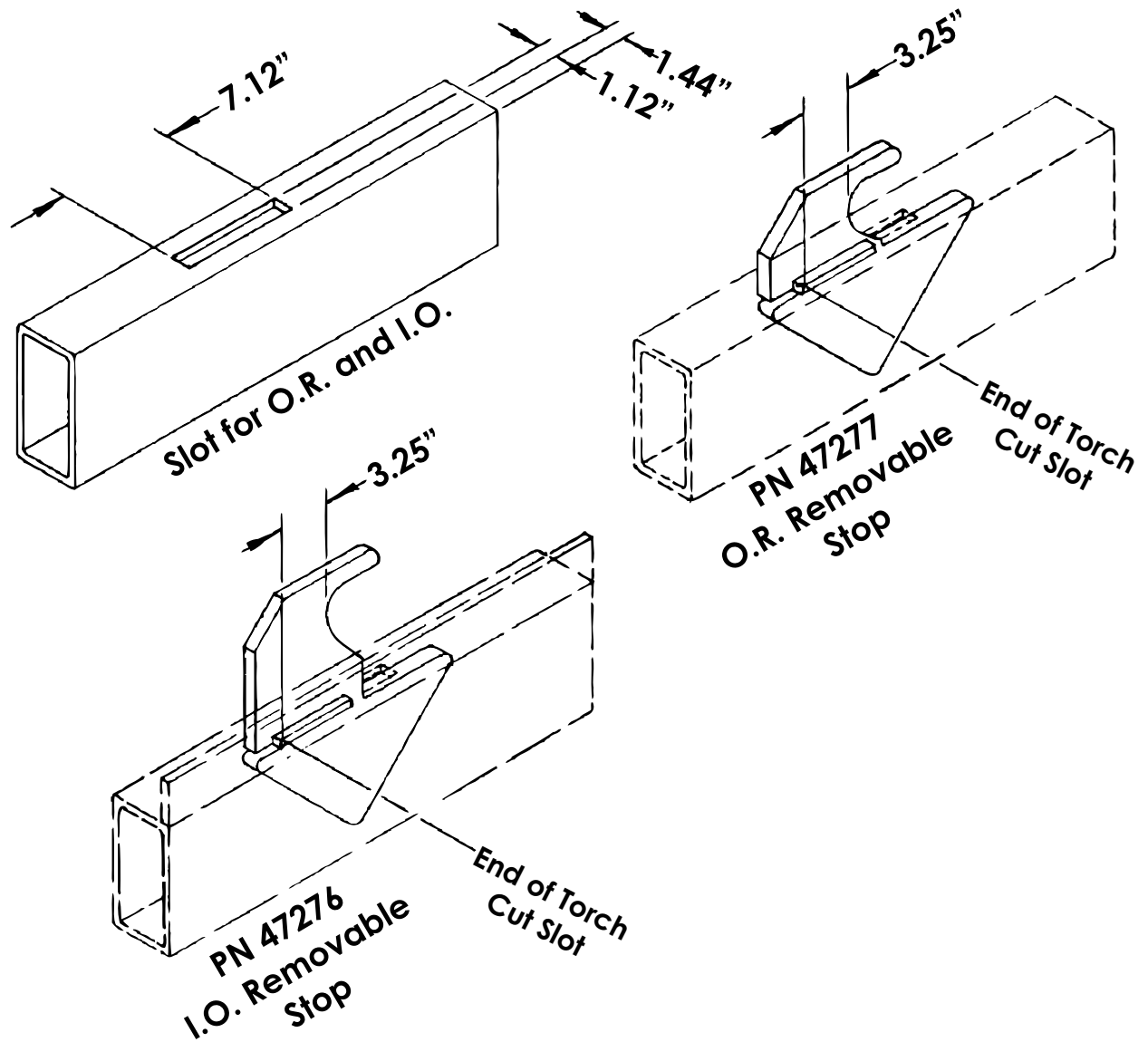

Step 14b: Intermediate Stop Installation

47272

I.O. Fold Down Stop

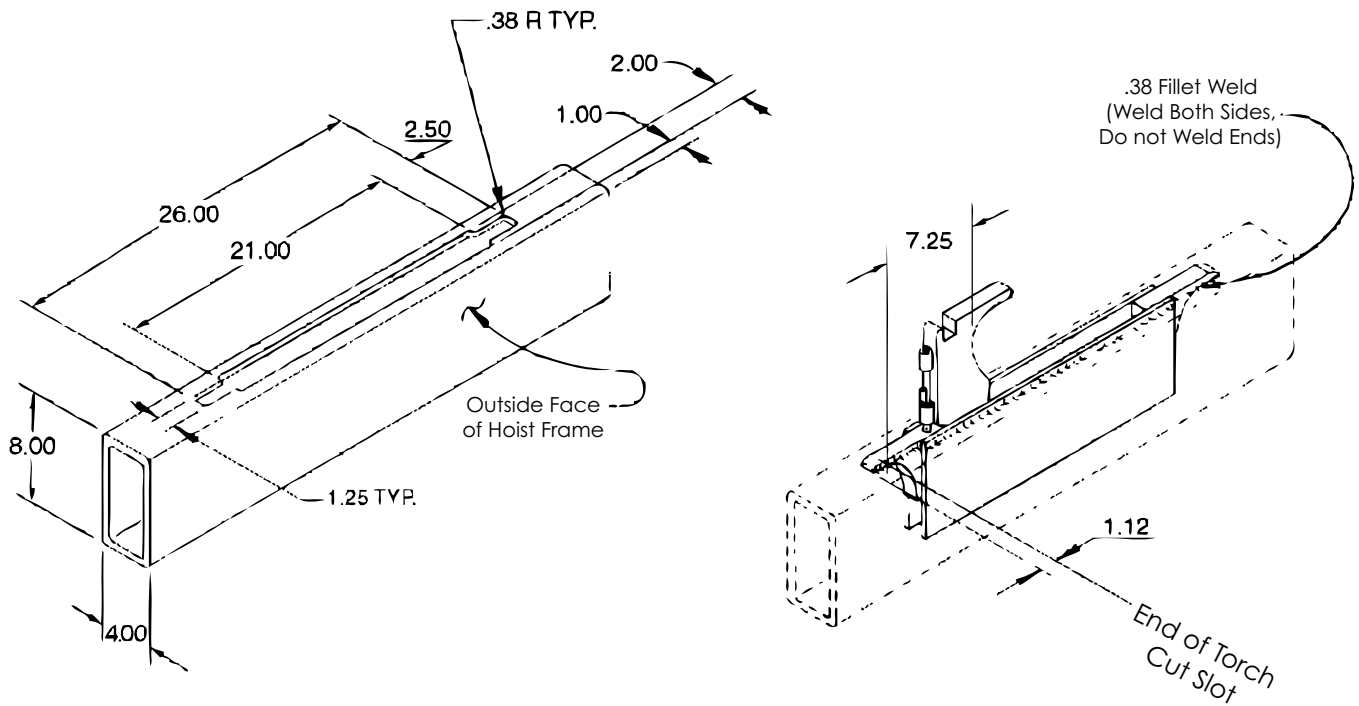

PN 45621
O.R. Fold Down Stop

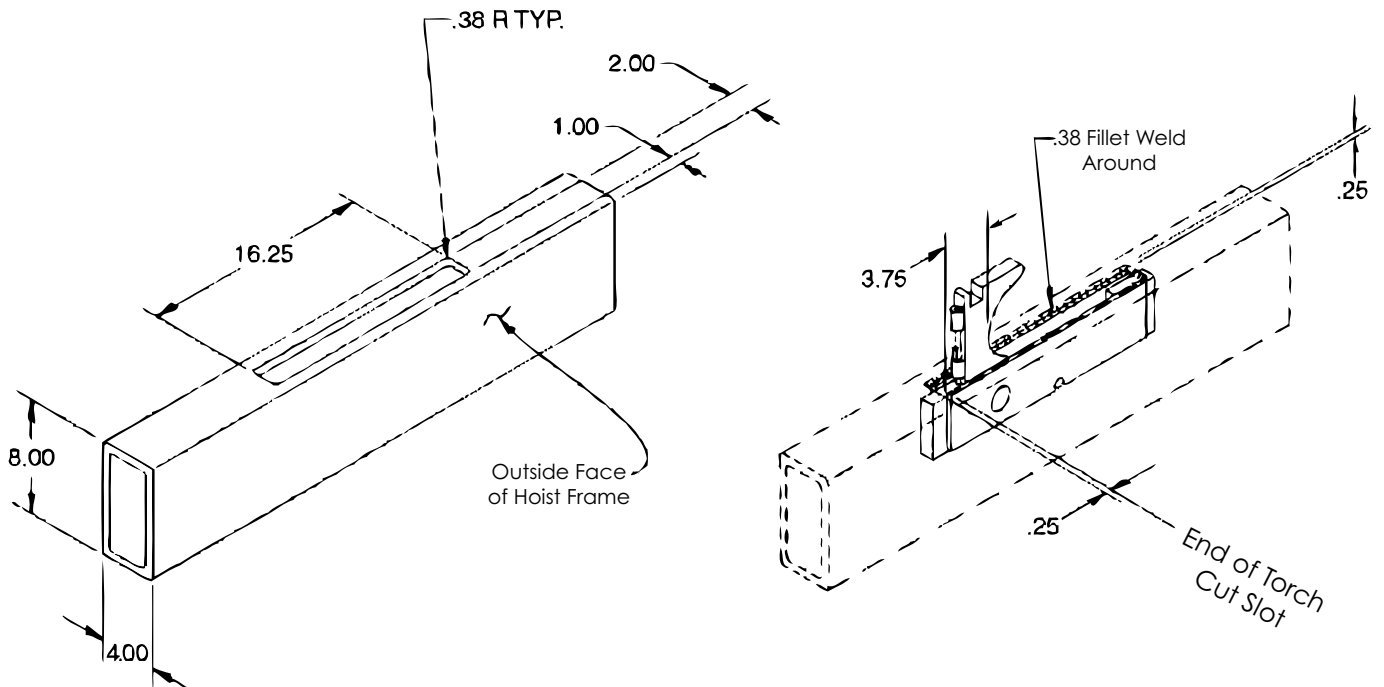

Step 15: Reflective Tape Installation

REF. ANSI Standard
Z245.1-1999
Z.2.16 Vehicle Conspicuity

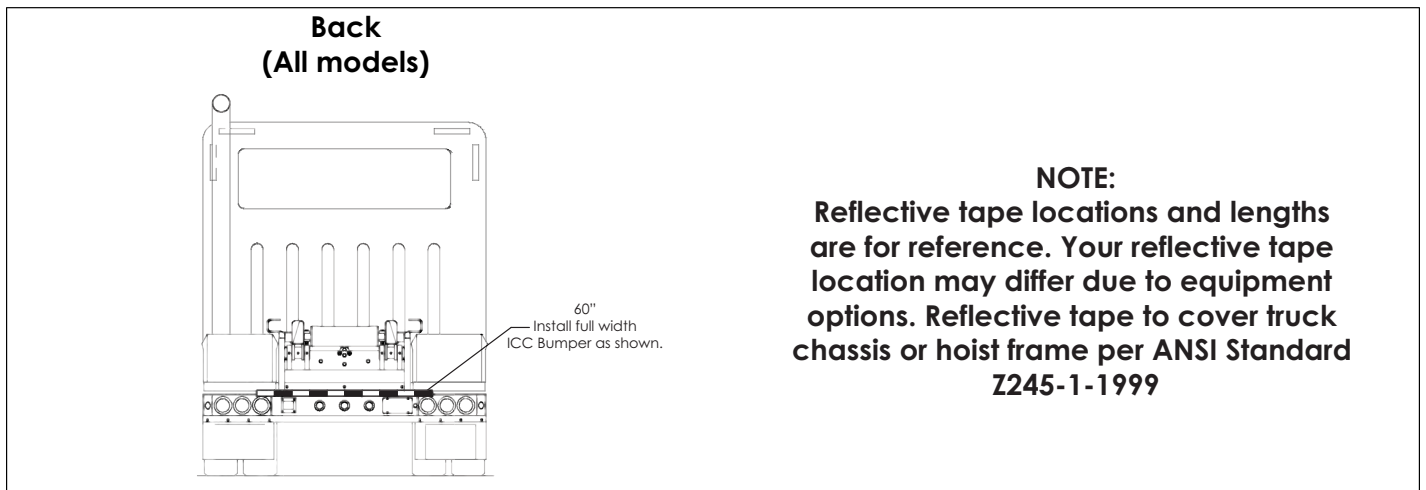
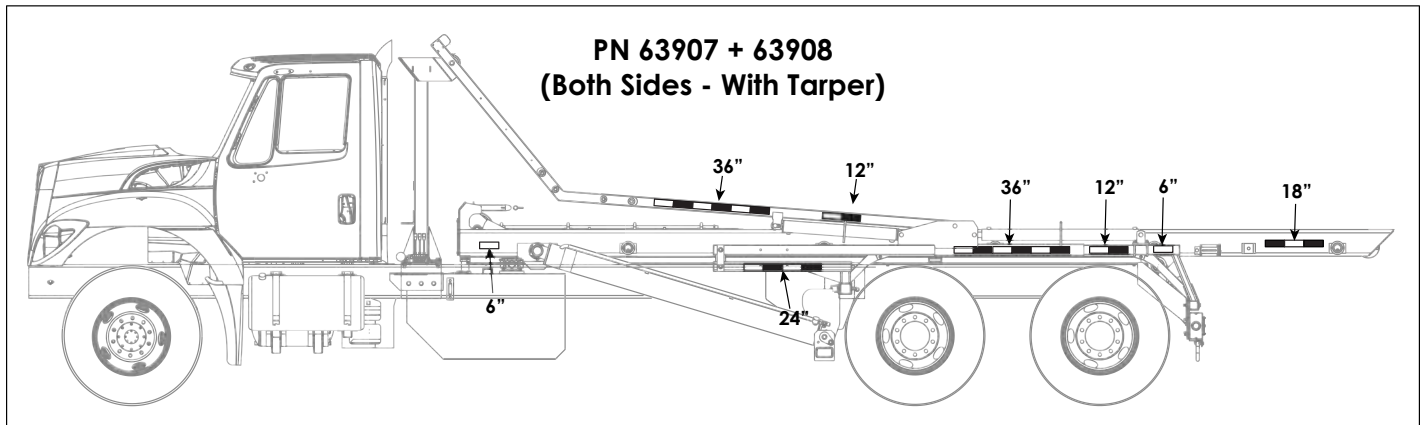
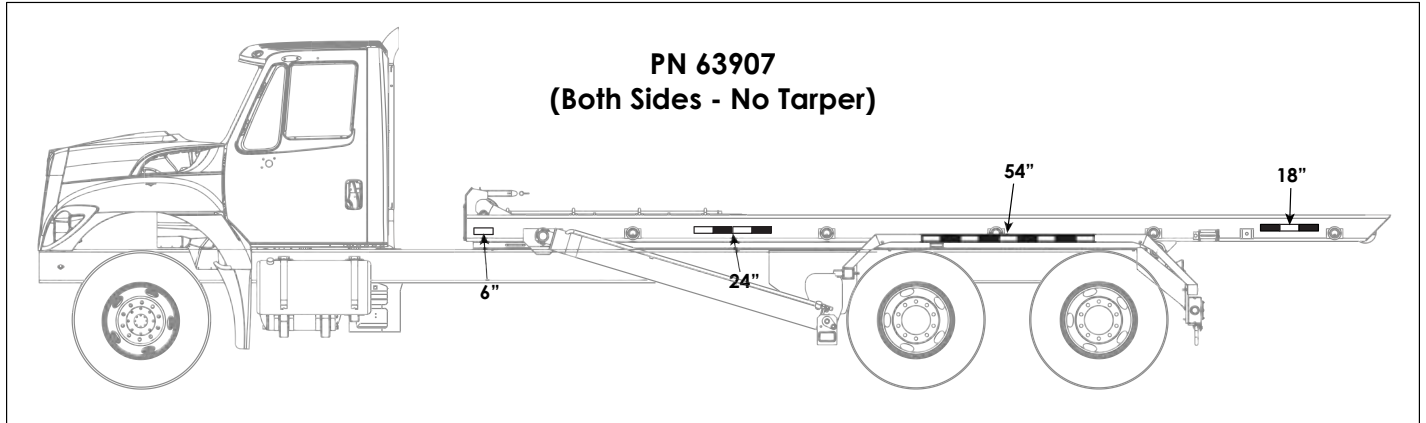

Step 16: Apply Decals

Bulkhead Reservoir
Note: Approximate placement as shown.

Standard Reservoir
Note: Approximate placement as shown.

Note: Approximate placement as shown. Keep decals below top of rollers.

PN 52791
(Rev F - 01/20/16)

Item	PN	Description	Suggested Location	Qty.
1	C5942	STELLAR SERIAL PLATE	Mounted on hoist rail as shown above. (Not included in kit)	1
2	35234	DECAL STELLAR MADE IN THE USA	On hoist rail as shown above.	1
3	55128	DECAL STELLAR LOGO 2.75X7.75	Both sides - On hoist rail as shown above. (Ship Qty 1 Loose)	3
4	45553	DECAL WARNING RAISED HOIST	Both sides - On hoist rail as shown above.	2
5	25627	DECAL CRUSH POINT	Both sides - On hoist rail as shown above.	6
6	45699	DECAL ICC BUMPER REQUIREMENT	On hoist rail as shown above.	1
7	52790	DECAL VB CONTROL	On reservoir near controls. (Not Shown - Cable75 Models)	1
8	45726	DECAL WARNING HYDRAULIC SAFETY	On reservoir. (Not Shown)	1
9	71955	DECAL WARNING CABLE HOIST	On reservoir and in cab. (Not Shown)	2
10	68024	DECAL WARNING UNTRAINED OP	On reservoir and in cab. (Not Shown)	2
11	45697	DECAL CAUTION PTO SPEED	In cab near PTO control. (Not Shown)	1
12	45906	DECAL HOIST UP	In cab near hoist up light. (Not Shown)	1
13	52681	DECAL STELLAR LOGO 6.00X16.50	Shipped Loose - Optional placement. (Not Shown)	2
14	79984	DECAL DANGER ELECTROCUTION	Front bumper.	1
13	0540	DECAL AMBER REFLECT 3.00 ROUND	Shipped Loose - Optional placement. (Not Shown)	2
13	0541	DECAL RED REFLECT 3.00 ROUND	Shipped Loose - Optional placement. (Not Shown)	4

Chapter 6 - Hydraulics - Electrical

Hydraulic Schematic

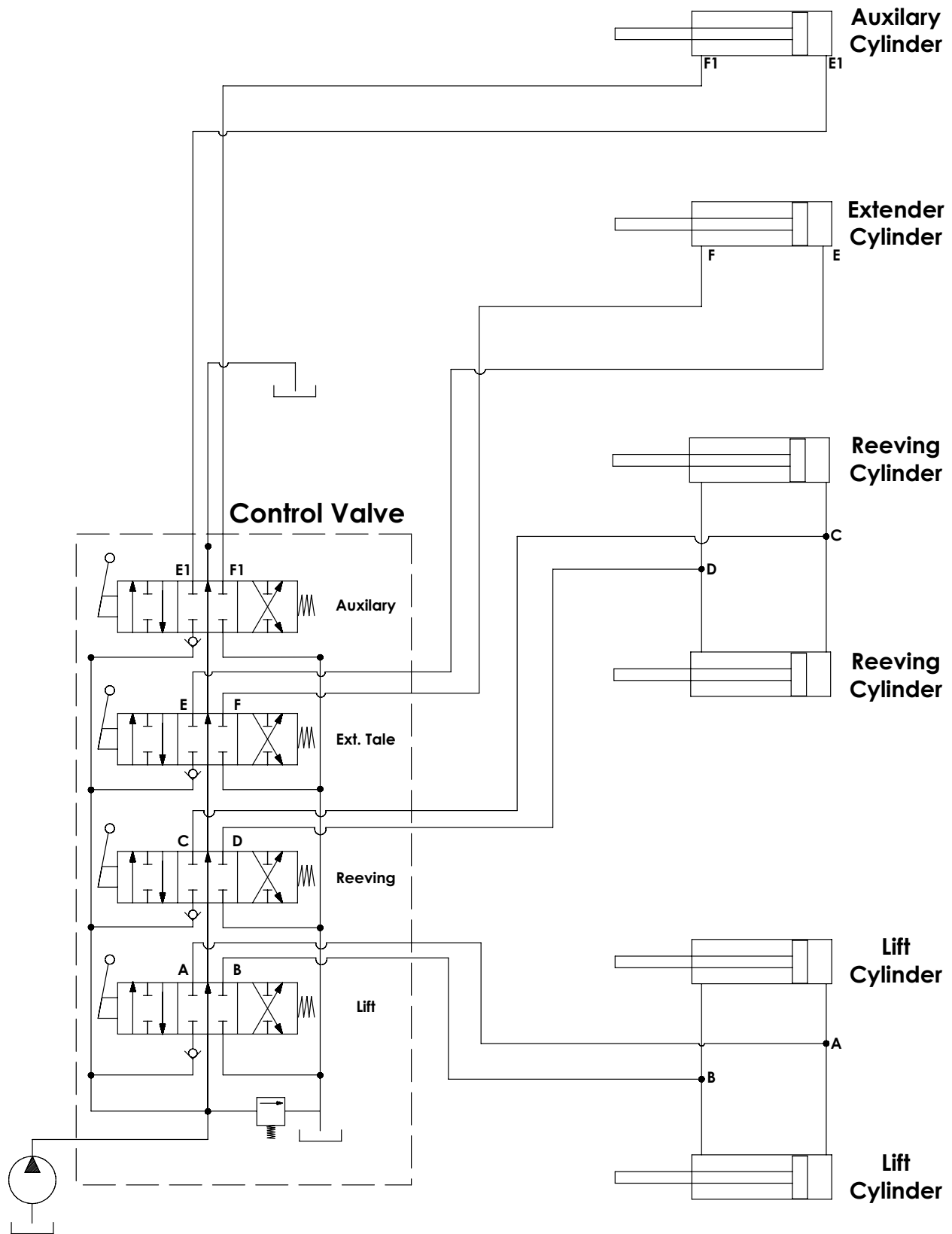

Hydraulic Routing - Standard Lift Cylinder

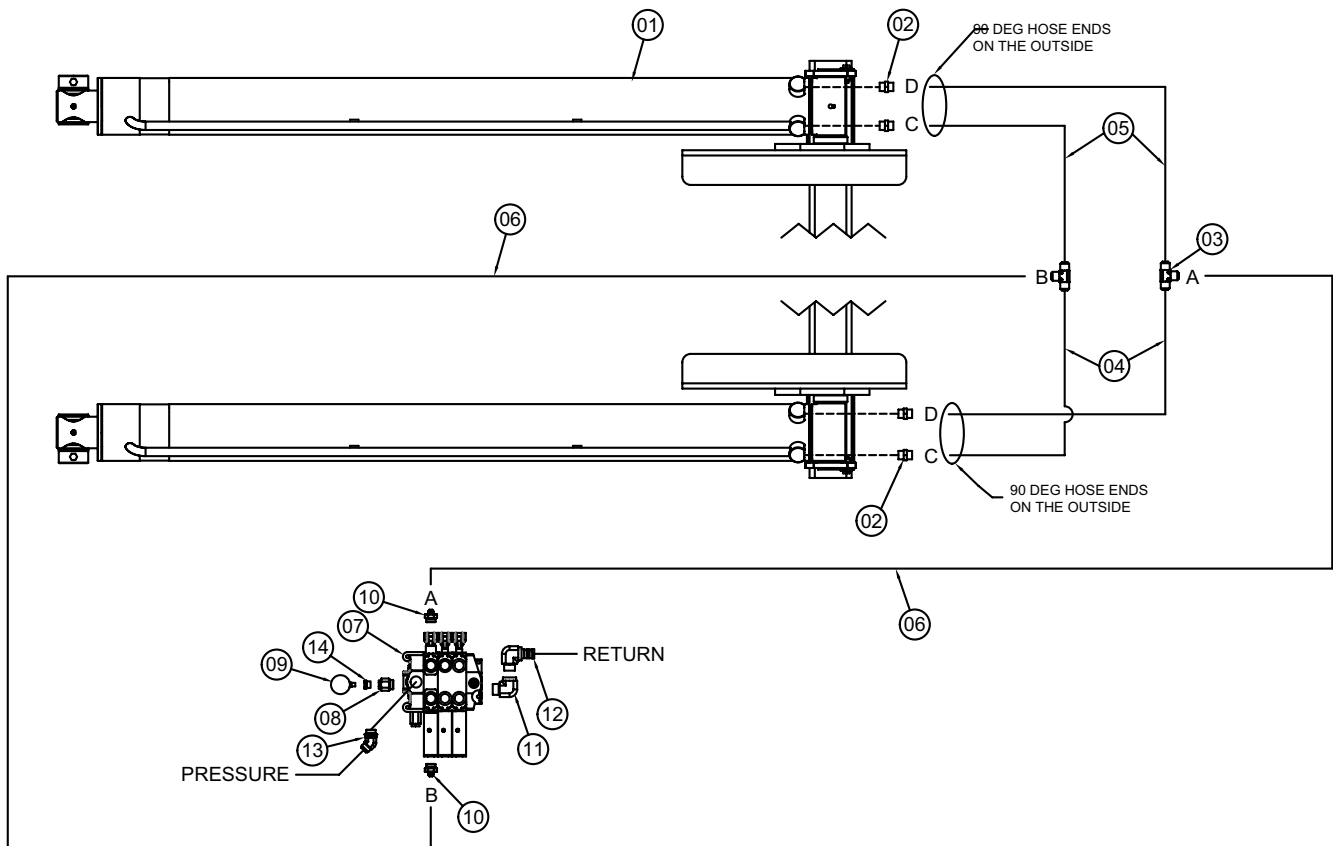

Standard Cylinder Mount

ITEM	PART	DESCRIPTION	QTY	ITEM	PART	DESCRIPTION	QTY
01	60132	CYLINDER 6.00X72.00 LIFT	2	08	D1306	FTG ADAPT MSTR/FSTR 16-12 F5OG5	1
02	C4498	FTG ADAPT MSTR/MJIC 12-F5OX-S	4	09	6397	GAUGE OIL LF 2.5 0-5000 CBM	1
03	45585	FTG TEE JIC 12 JTX-S	2	10	C4498	FTG 12-12 MJ-MORB STRAIGHT	2
04	64064	HOSE 0.75(3000PSI)-12FJS SHORT-12FJS 90 SHORT-60CL	2	11	9758	FTG ST TH-F PIPE EL 90 6805-20-20	1
05	64065	HOSE 0.75(3000PSI)-12FJS SHORT-12FJS 90 SHORT-70CL	2	12	8617	FTG 20-20 HB-MP 90	1
06	45904	HOSE 0.75(3000PSI)-12FJS SHORT-12FJS SHORT-188.50CL	2	13	45802	FTG ADAPT MJIC/MORING 16-16 45 DEG	1
07	59843	VB 3-SECT VA20 KIT	1	14	30541	FTG ML O'RING/FM PIPE 6405-12-04	1

Hydraulic Routing - Telescopic Lift Cylinder

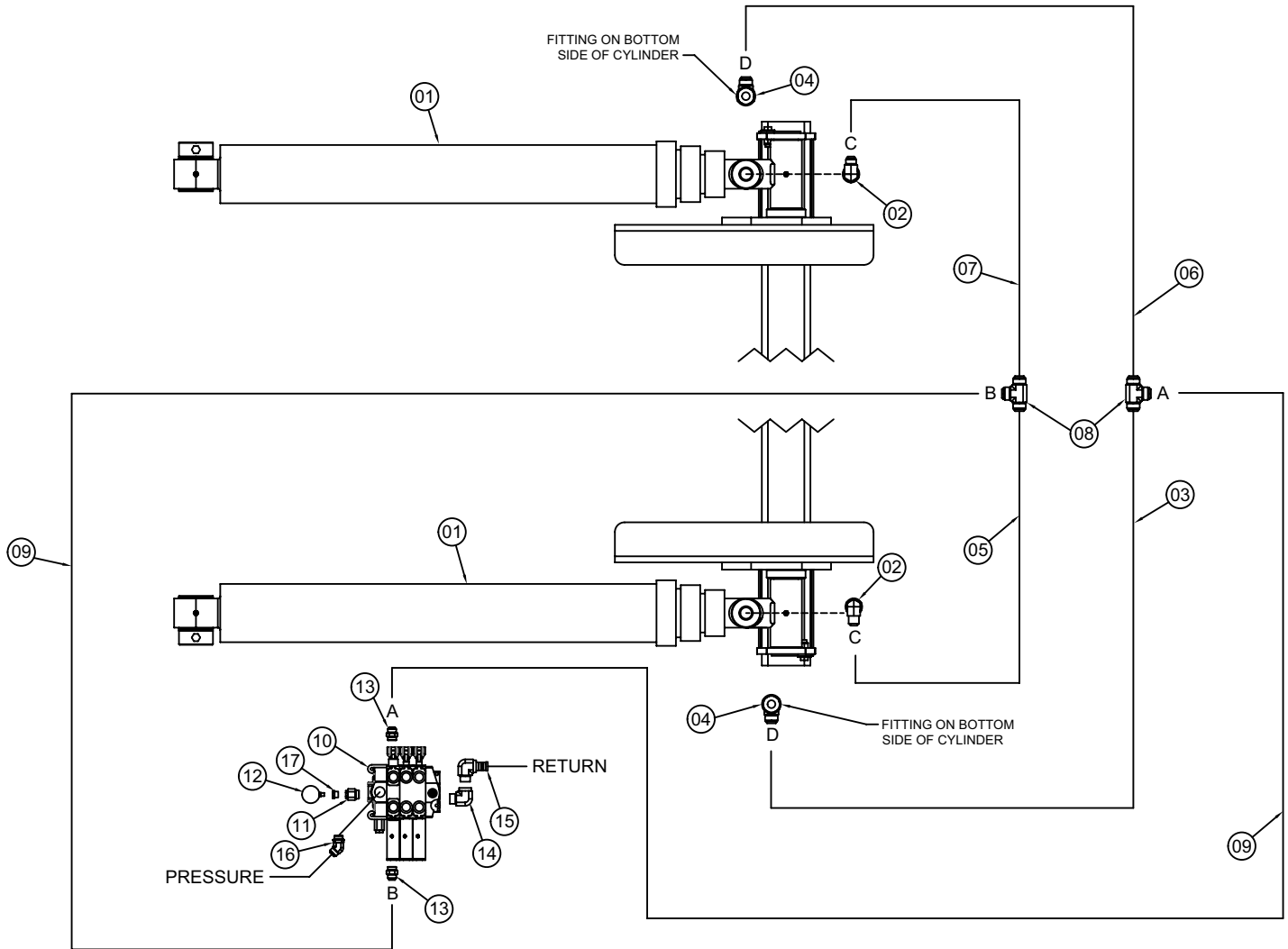

Telescopic Cylinder Mount

ITEM	PART	DESCRIPTION	QTY	ITEM	PART	DESCRIPTION	QTY
01	45737	CYLINDER 5.50X185.75 TELO KPAC	2	10	59843	VB 3-SECT VA20 KIT	1
02	46114	FTG MJIC/MSTR 90 12-16 C50X	2	11	D1306	FTG ADAPT MSTR/FSTR 16-12 F5OG5	1
03	64702	HOSE 1.00(3000PSI)-16FJS SHORT-12FJS SHORT-60CL	1	12	6397	GAUGE OIL LF 2.5 0-5000 CBM	1
04	46113	FTG 90DEG MSTR/MJIC 16-20C50X	2	13	C4498	FTG 12-12 MJ-MORB STRAIGHT	2
05	64064	HOSE 0.75(3000PSI)-12FJS SHORT-12FJS 90 SHORT-60CL	1	14	9758	FTG ST TH-F PIPE EL 90 6805-20-20	1
06	64703	HOSE 1.00(3000PSI)-16FJS SHORT-12FJS SHORT-70CL	1	15	8617	FTG 20-20 HB-MP 90	1
07	64065	HOSE 0.75(3000PSI)-12FJS SHORT-12FJS 90 SHORT-70CL	1	16	45802	FTG ADAPT MJIC/MORING 16-16 45 DEG	1
08	45585	FTG TEE JIC 12 JTX-S	2	17	30541	FTG ML O'RING/FM PIPE 6405-12-04	1
09	64701	HOSE 1.00(3000PSI)-12FJS SHORT-12FJS SHORT-110CL	2				

Hydraulic Routing - Reverse Mount Lift Cylinder

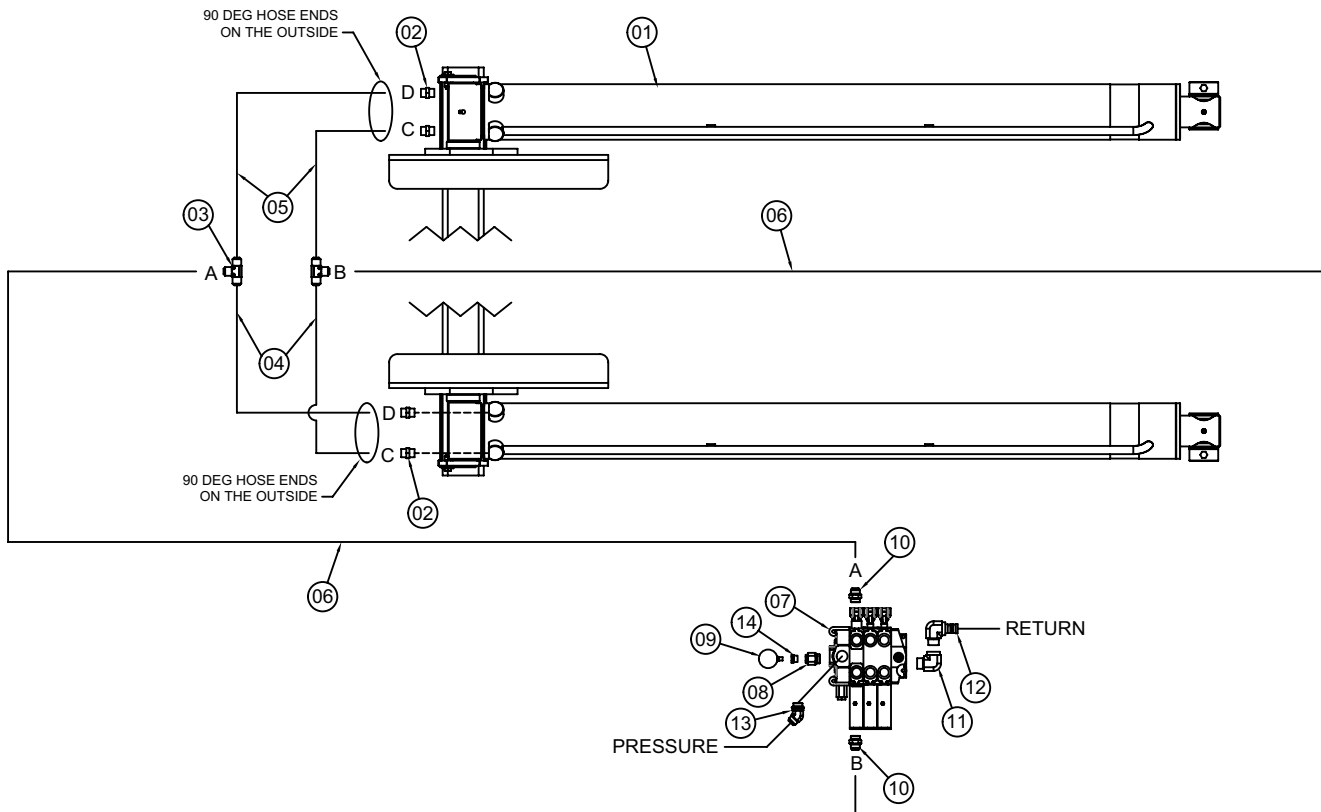

Reverse Cylinder Mount

ITEM	PART	DESCRIPTION	QTY	ITEM	PART	DESCRIPTION	QTY
01	60132	CYLINDER 6.00X72.00 LIFT	2	08	D1306	FTG ADAPT MSTR/FSTR 16-12 F5OG5	1
02	C4498	FTG ADAPT MSTR/MJIC 12-F5OX-S	4	09	6397	GAUGE OIL LF 2.5 0-5000 CBM	1
03	45585	FTG TEE JIC 12 JTX-S	2	10	C4498	FTG 12-12 MJ-MORB STRAIGHT	2
04	64064	HOSE 0.75(3000PSI)-12FJS SHORT-12FJS 90 SHORT-60CL	2	11	9758	FTG ST TH-F PIPE EL 90 6805-20-20	1
05	64065	HOSE 0.75(3000PSI)-12FJS SHORT-12FJS 90 SHORT-70CL	2	12	8617	FTG 20-20 HB-MP 90	1
06	46111	HOSE 0.75(3000PSI)-12FJS SHORT-12FJS SHORT-41.50CL	2	13	45802	FTG ADAPT MJIC/MORING 16-16 45 DEG	1
07	59843	VB 3-SECT VA20 KIT	1	14	30541	FTG ML O'RING/FM PIPE 6405-12-04	1

Reverse Mount Lift Cylinder Mounting Kit - PN 56094

Part 1

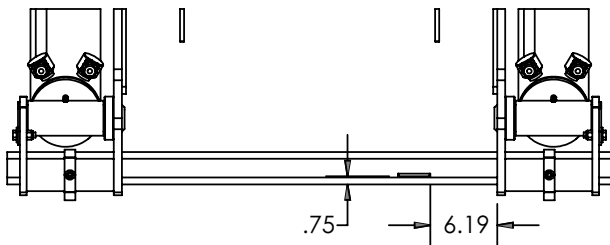
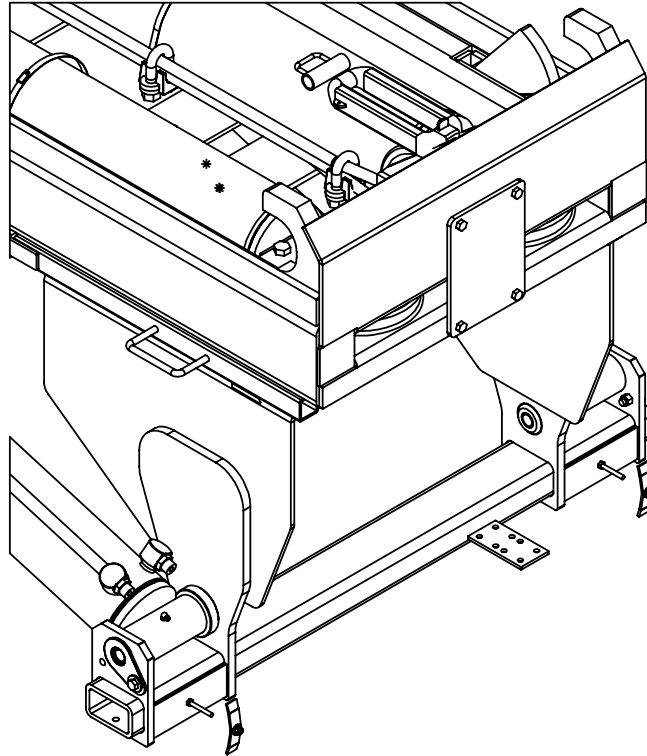

NOTE: PN:45143 ALWAYS WELDED ON STREET SIDE

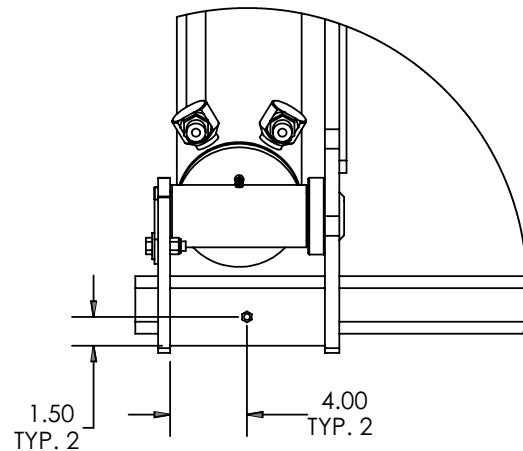
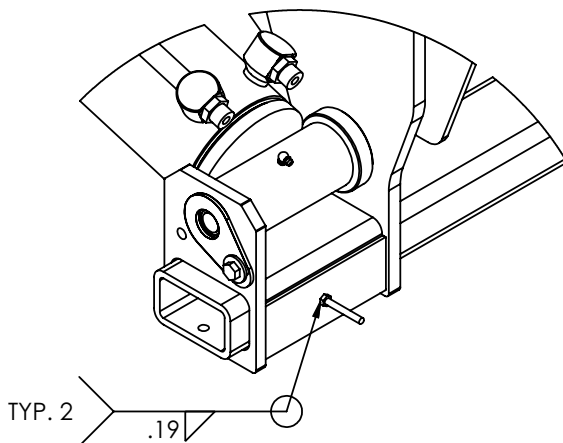
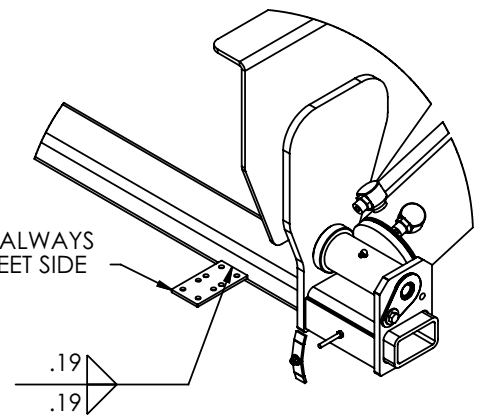

Reverse Mount Lift Cylinder Mounting Kit - PN 56094

Part 2

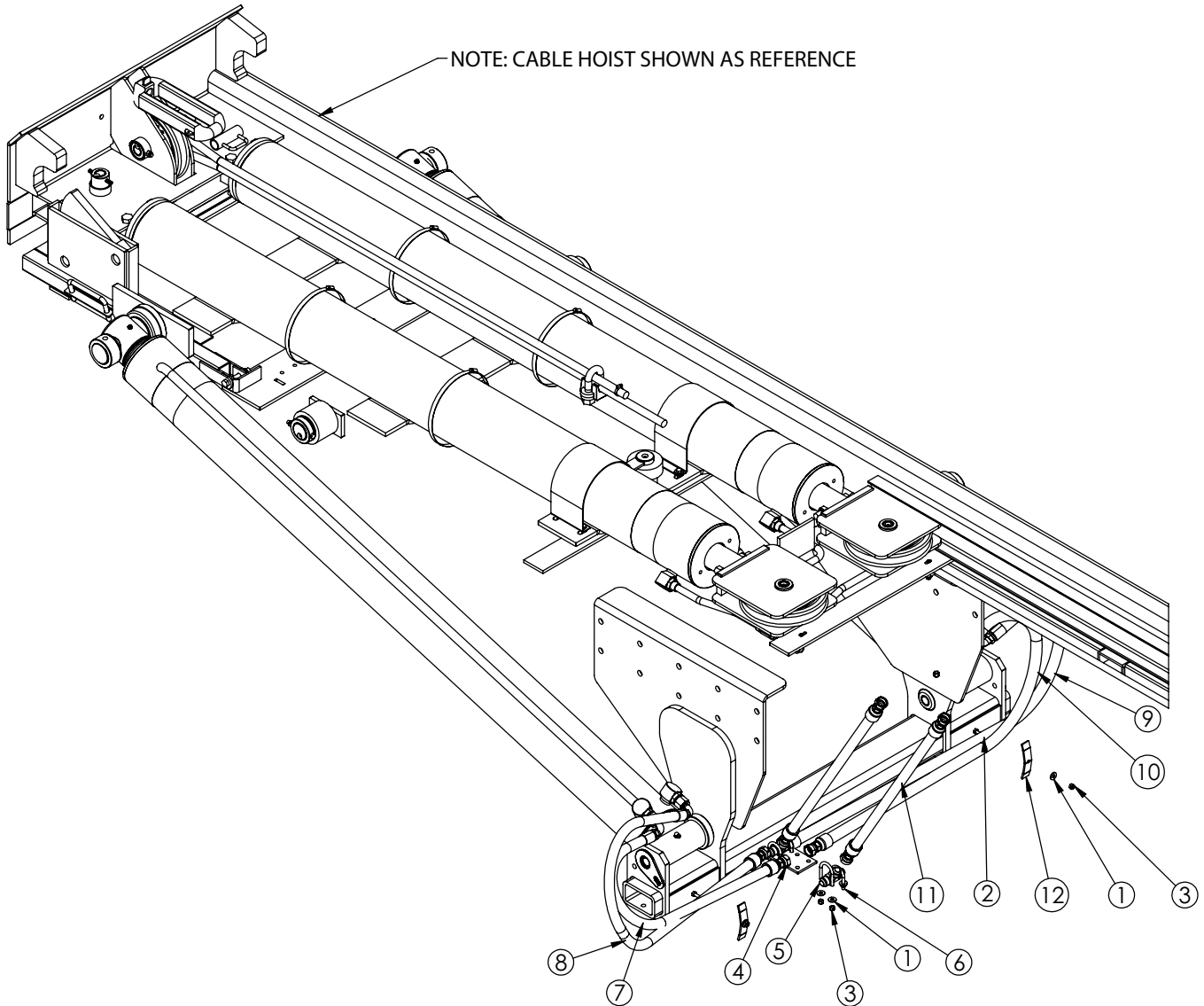

ITEM	PART	DESCRIPTION	QTY.
1	0343	WASHER 0.31 USS FLAT ZINC	10
2	0487	CAP SCR 0.31-18X1.75 HHGR5	2
3	0342	NUT 0.31-18 HHGR5 NYLOC	10
4	45143PC	PLATE 0.25X3.00X5.75	1
5	45585	FTG 12-12-12-MJ-MJ-MJ TEE	2
6	45948	U BOLT 0.31X1.50X2.25 RD	4
7	64064	HOSE 0.75(471TC-06-39-12-12-12-60)	1
8	64064	HOSE 0.75(471TC-06-39-12-12-12-60)	1
9	64065	HOSE 0.75(471TC-06-39-12-12-12-70)	1
10	64065	HOSE 0.75(471TC-06-39-12-12-12-70)	1
11	45904	HOSE 0.75x192 JIC F KPAC	2
12	3381PC	HOSE CLAMP BOLT ON 1210 CRANE	2

ITEMS NOT SHOWN: 45767 (VB TO REEVING PORT TUBES)

Hydraulic Routing - Reeving Cylinder

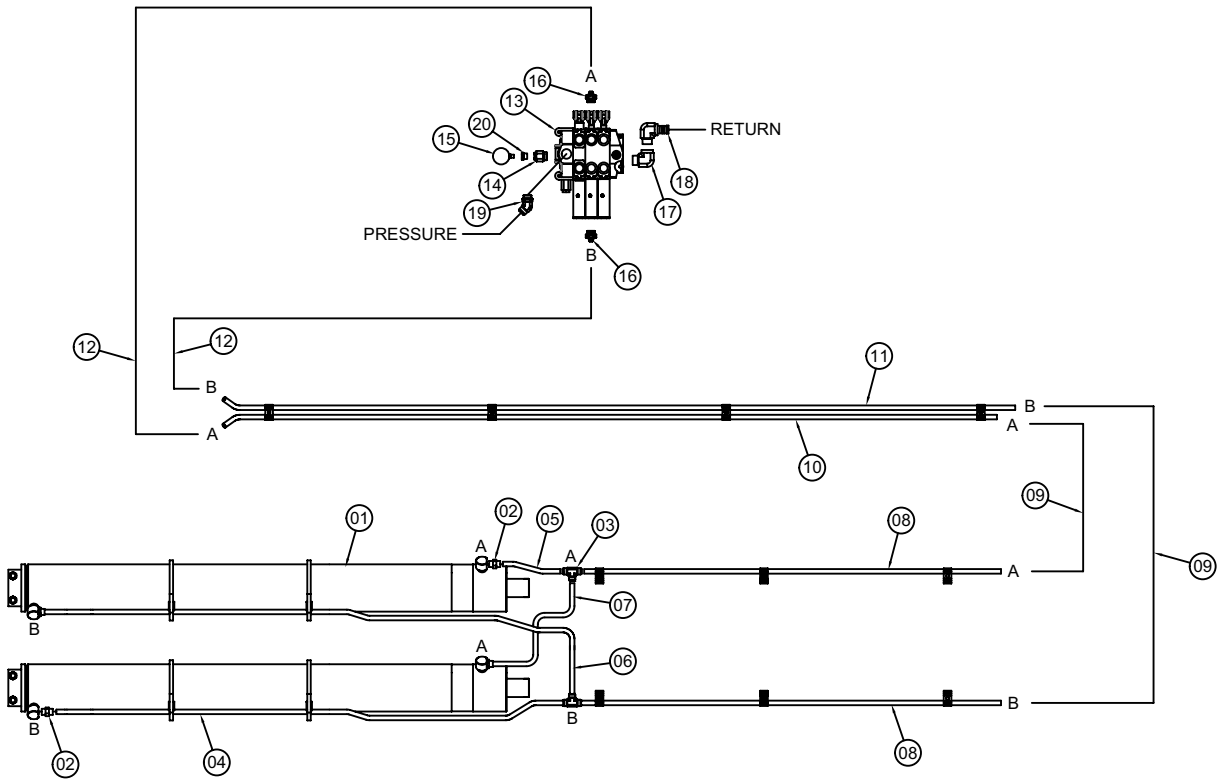

Reeving Cylinder

ITEM	PART	DESCRIPTION	QTY	ITEM	PART	DESCRIPTION	QTY
01	45243	CYLINDER 7.00X80.00 KPAC	2	10	45593	TUBE ASM 0.75X176.00 JIC KP6024-462 YZ	1
*	45349	CYLINDER 7X90 DA WINCH KPAC	2	11	45592	TUBE ASM 0.75X176.00 JIC KP6024-462 YZ	1
02	C4498	FTG ADAPT MSTR/MJIC 12-F5OX-S	4	12	45767	HOSE 0.75(3000PSI)-12FJS SHORT-12MJ-70CL	2
03	45585	FTG TEE JIC 12 JTX-S	2	13	59843	VB 3-SECT VA20 KIT	1
04	58392	TUBE ASM 0.75X94.94 JIC YZ	1	14	D1306	FTG ADAPT MSTR/FSTR 16-12 F5OG5	1
*	60323	TUBE ASM 0.75X104.94 JIC YZ	1	15	6397	GAUGE OIL LF 2.5 0-5000 CBM	1
05	58389	TUBE ASM 0.75X11.50 JIC YZ	1	16	C4498	FTG 12-12 MJ-MORB STRAIGHT	2
06	58391	TUBE ASM 0.75X96.82 JIC YZ	1	17	9758	FTG ST TH-F PIPE EL 90 6805-20-20	1
*	60324	TUBE ASM 0.75X106.82 JIC YZ	1	18	8617	FTG 20-20 HB-MP 90	1
07	58390	TUBE ASM 0.75X14.06 JIC YZ	1	19	45802	FTG ADAPT MJIC/MORING 16-16 45 DEG	1
08	45590	TUBE ASM 0.75X93.00 JIC 24-429 YZ	2	20	30541	FTG ML O'RING/FM PIPE 6405-12-04	1
09	45591	HOSE 0.75(3000PSI)-12MJ-12MJ-25CL	2				

* USED FOR 194" MODLES

Hydraulic Routing - Tail Extension IOX Cylinder Mount

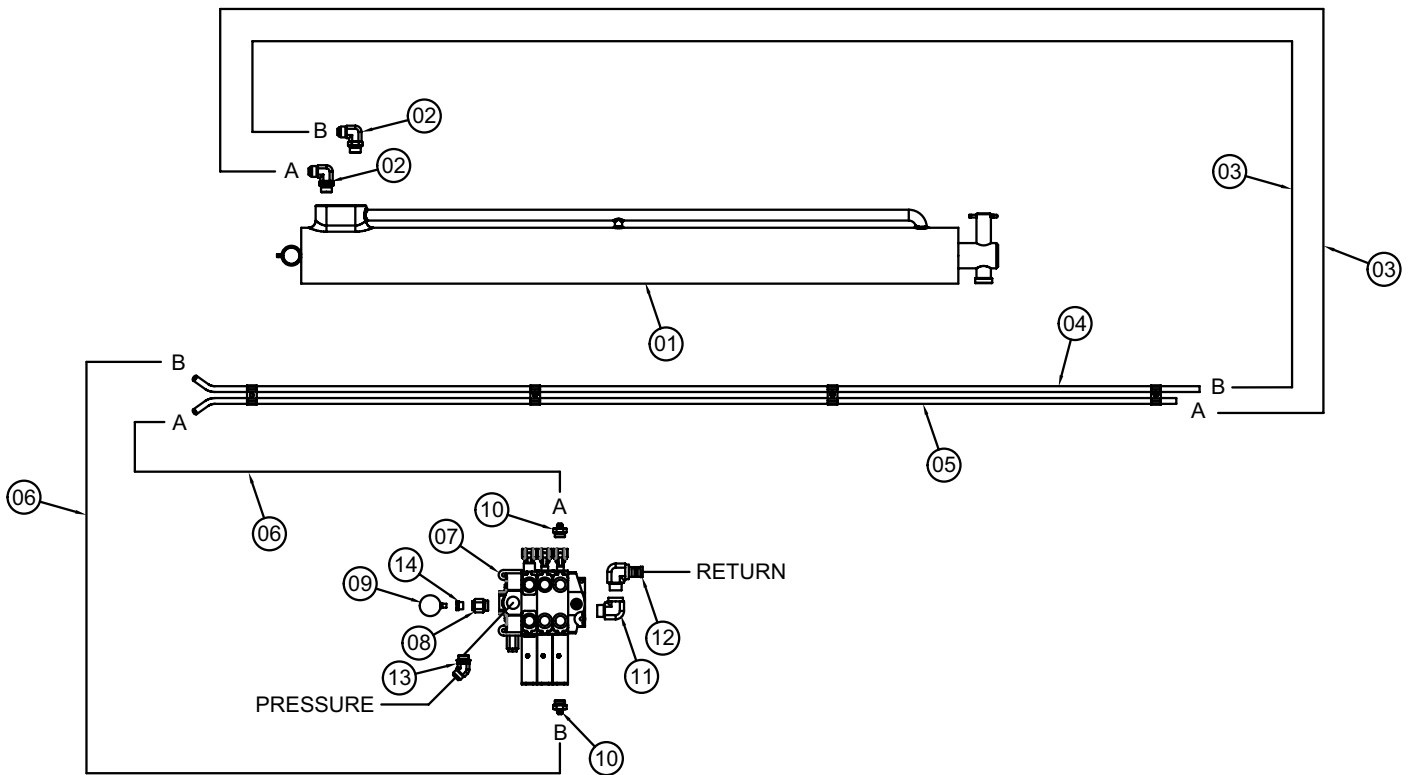

Tail Extension IOX Cylinder Mount

ITEM	PART	DESCRIPTION	QTY	ITEM	PART	DESCRIPTION	QTY
01	46153	CYLINDER 3.50X40.00 KP60 IOX	1	08	D1306	FTG ADAPT MSTR/FSTR 16-12 F5OG5	1
02	46680	FTG ADAPT MSTR/MJIC 8 F5OX-S	2	09	6397	GAUGE OIL LF 2.5 0-5000 CBM	1
03	46673	HOSE 0.50(3000PSI)-8FJS SHORT-8MJ-25CL	2	10	D1189	FTG 8-12 MJ-MORB STRAIGHT	2
04	46129	TUBE ASM 0.50X179.00 JIC KP6024-468	1	11	9758	FTG ST TH-F PIPE EL 90 6805-20-20	1
05	46128	TUBE ASM 0.50X176.00 JIC KP6024-467	1	12	8617	FTG 20-20 HB-MP 90	1
06	46644	HOSE 0.50(3000PSI)-8FJS SHORT-8MJ-70CL	2	13	45802	FTG ADAPT MJIC/MORING 16-16 45 DEG	1
07	59843	VB 3-SECT VA20 KIT	1	14	30541	FTG ML O'RING/FM PIPE 6405-12-04	1

Hydraulic Routing - Tail Extension ORX Cylinder Mount

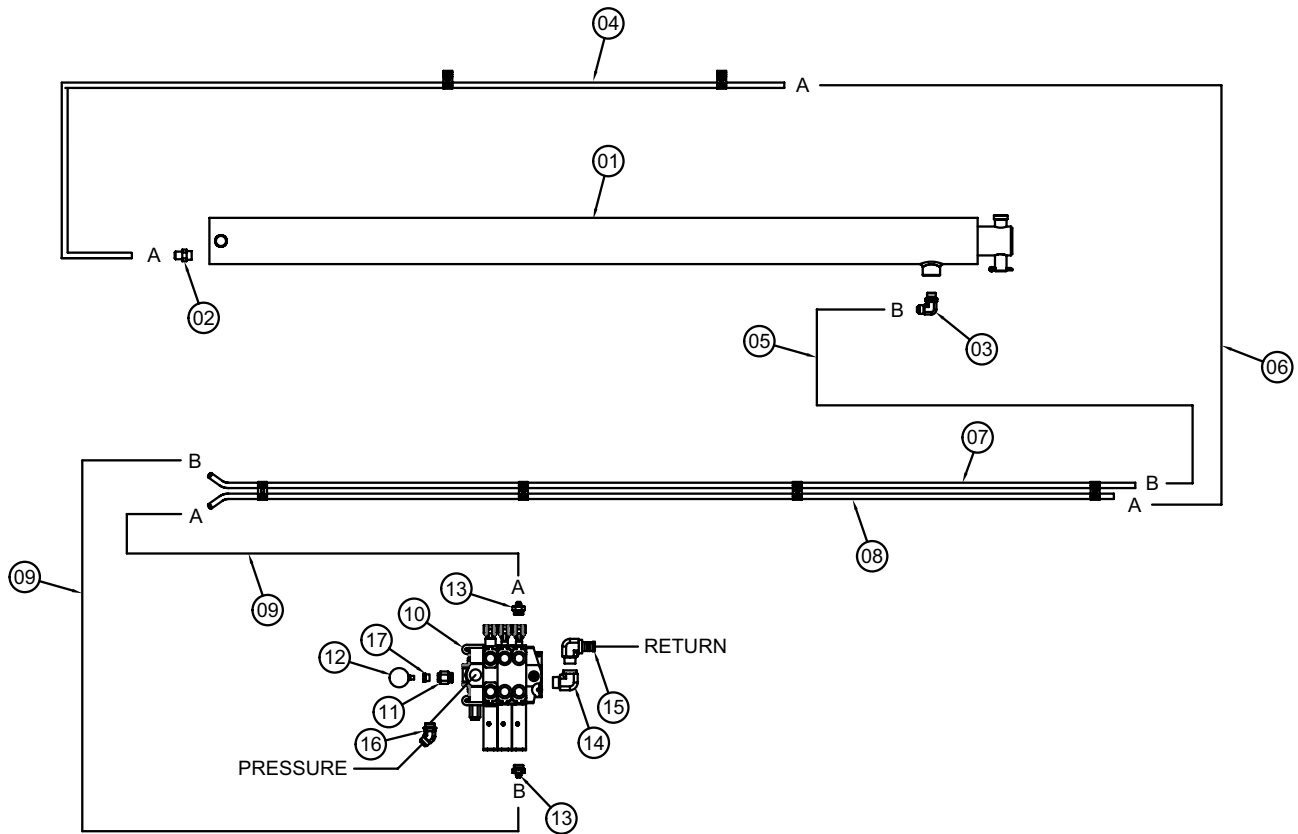

Tail Extension ORX Cylinder Mount

ITEM	PART	DESCRIPTION	QTY	ITEM	PART	DESCRIPTION	QTY
01	45611	CYLINDER 3.50X80.00 KP60 ORX	1	10	59843	VB 3-SECT VA20 KIT	1
02	4594	FTG ADAPT MSTR/MJIC 8 F5OX-S	1	11	D1306	FTG ADAPT MSTR/FSTR 16-12 F5OG5	1
03	46680	FTG MJIC/MSTR 90 8 C5OX	1	12	6397	GAUGE OIL LF 2.5 0-5000 CBM	1
04	62880	TUBE ASM 0.50X62.00 JIC YZ	1	13	D1189	FTG 8-12 MJ-MORB STRAIGHT	2
05	46673	HOSE 0.50(3000PSI)-8FJS SHORT-8MJ-25CL	1	14	9758	FTG ST TH-F PIPE EL 90 6805-20-20	1
06	46893	HOSE 0.50(3000PSI)-8MJ-8MJ-25CL	1	15	8617	FTG 20-20 HB-MP 90	1
07	46129	TUBE ASM 0.50X179.00 JIC KP6024-468	1	16	45802	FTG ADAPT MJIC/MORING 16-16 45 DEG	1
08	46128	TUBE ASM 0.50X176.00 JIC KP6024-467	1	17	30541	FTG ML O'RING/FM PIPE 6405-12-04	1
09	46644	HOSE 0.50(3000PSI)-8FJS SHORT-8MJ-70CL	2				

Electrical Schematics

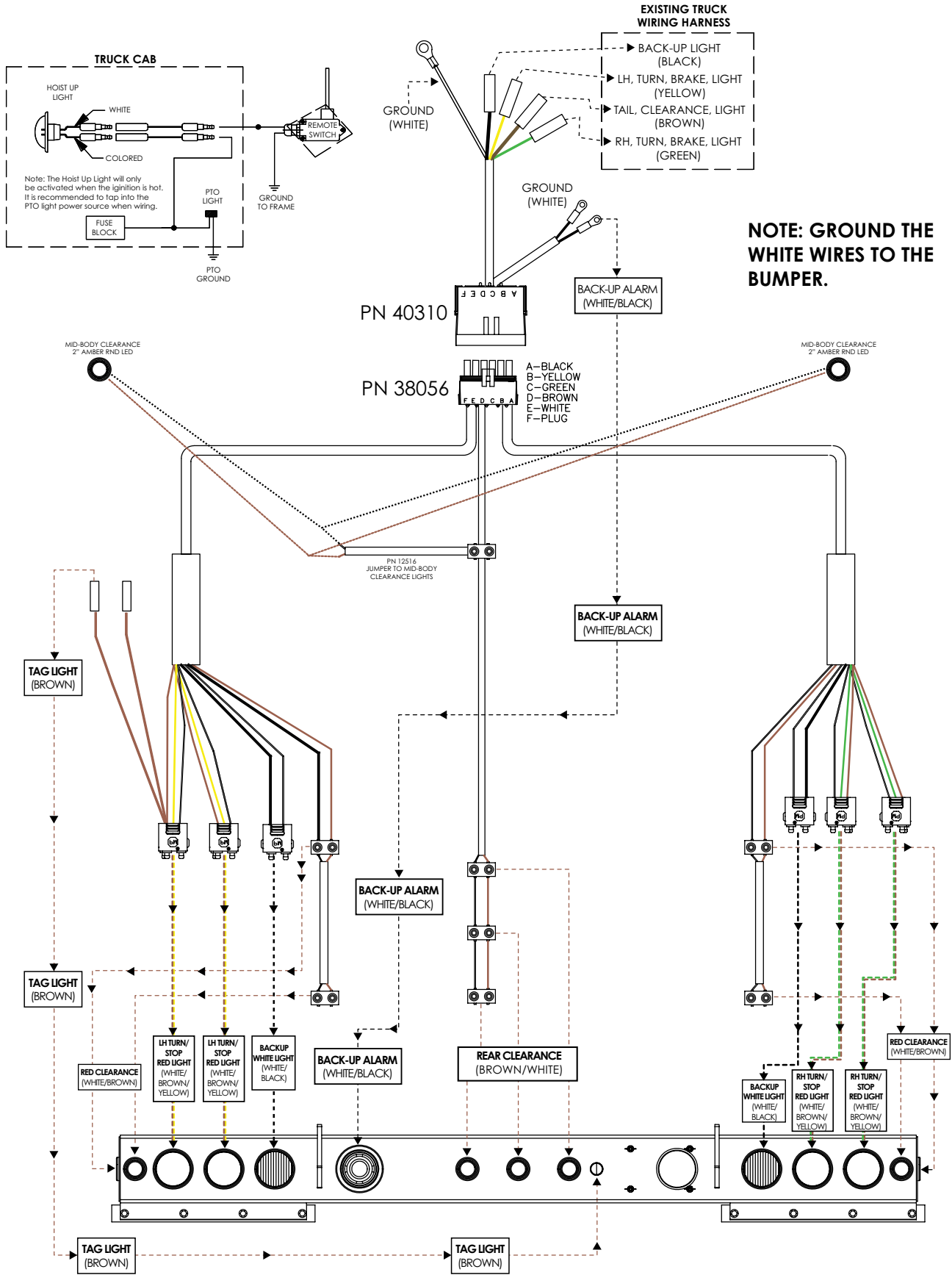

Chapter 7 - Assembly Drawings

Main Hoist Assembly

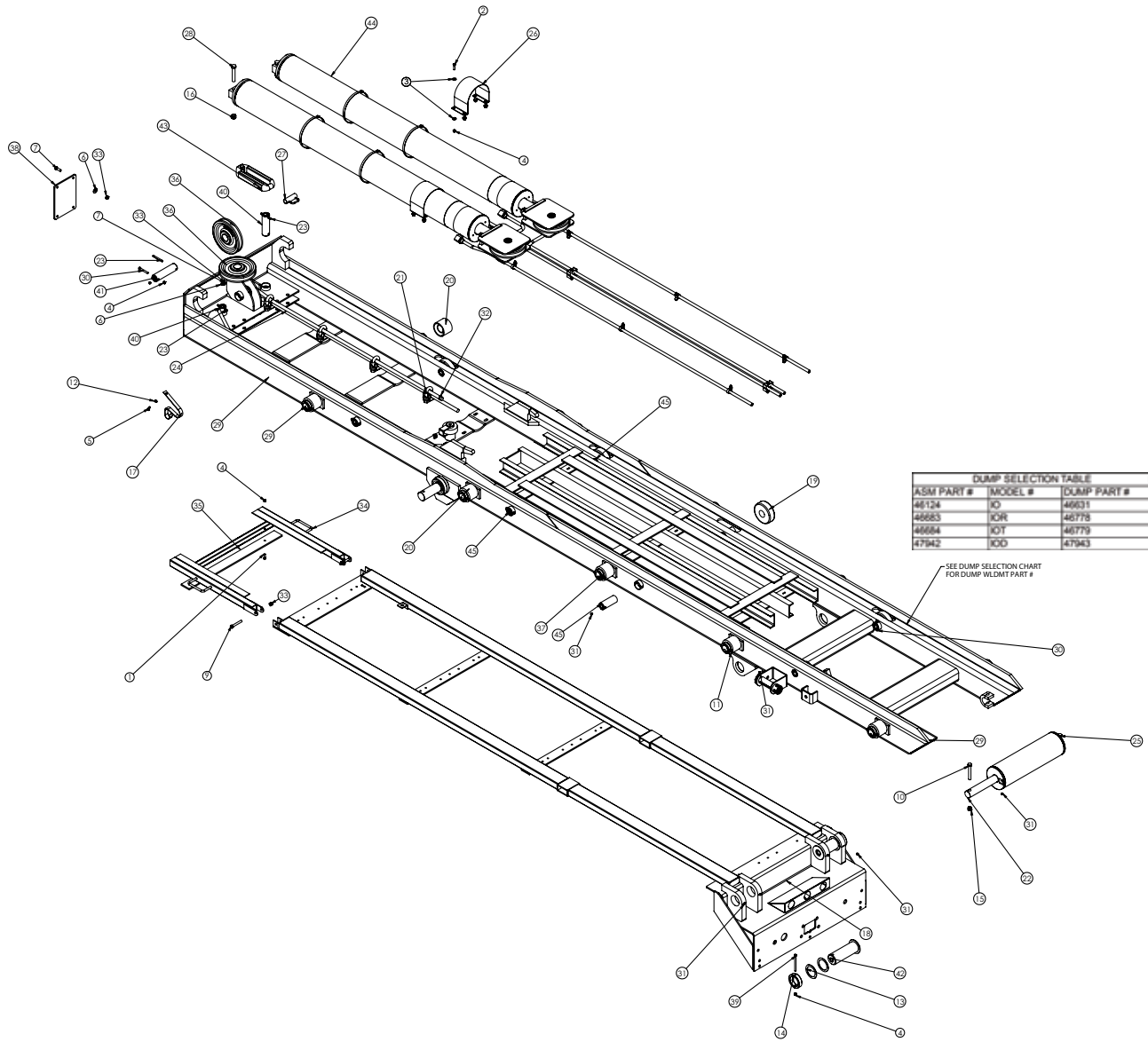

ITEM	PART	DESCRIPTION	QTY.	ITEM	PART	DESCRIPTION	QTY.
1	0335	CAP SCR 0.38-16X1.25 HHGR5	2	24	45556	CABLE ASM 0.88X71 FT 6X37 EXIWRC	1
2	0345	CAP SCR 0.38-16X1.50 HHGR5	4	25	45564	REAR ROLLER ASSEMBLY KP60	1
3	0346	WASHER 0.38 USS FLAT ZINC	12	26	45583	STRAP WLDMT CYLINDER REEVING KP60	2
4	0347	NUT 0.38-16 HHGR5 NYLOC	33	27	45596	HANDLE WLDMT LOCK STRAP KP60	1
5	0351	CAP SCR 0.38-16X1.00 HHGR5	1	28	45623	CAP SCR 0.75-10X4.50 HHGR5	4
6	0352	WASHER 0.50 USS FLAT ZINC	4	29	46631	DUMP KP60 174 IO	1
7	0359	CAP SCR 0.50-13X1.50 HHGR5	4	30	C0949	CAP SCR 0.38-16X3.00 HHGR5	11
8	0427	MACHY WASHER 2.00ID 10GA	10	31	c1592	ZERK 1/8 NPT STRAIGHT	27
9	0505	CAP SCR 0.50-13X3.50 HHGR5	2	32	C4666	HOSE CLAMP #12 SS	1
10	0512	CAP SCR 0.63-11X4.50 HHGR5	2	33	C6106	NUT 0.50-13 HHGR5 NYLOC	6
11	0532	CAP SCR 0.38-16X3.75 HHGR5	10	34	45096PC	PROP WLDMNT	1
12	0523	WASHER 0.38 LOCK	1	35	45579PC	FLAT CROSS MEMBER PROP KP60	1
13	1589	MACHY WASHER 3.00ID 14GA	4	36	45139	SHEAVE 10IN X .88 CABLE ASM KP60	3
14	26168PC	COLLAR RETAINING 3.01X4.00X1.00	2	37	45372PC	COLLAR RETAINING 3.00X2.03X.75	10
15	2826	NUT 0.63-11 HHGR5 NYLOC	2	38	45584PC	PLATE COVER FRONT KP60	1
16	2828	NUT 0.75-10 HHGR5 NYLOC	4	39	0578	CAP SCR 0.38-16X5.00 HHGR5	2
17	42393	SPRING FLAT K PAC	1	40	45481ZP	VERTICAL SHEAVE SHAFT KPAC	2
18	45177	BASE CABLE HOIST SI60	1	41	45138ZP	PIN SHEAVE AND CABLE SHAFT KPAC	1
19	45304	ROLLER 2.00X6.00X1.94 INSIDE	8	42	45560ZP	PIN WLDMT REAR HINGE KP60	2
20	45373	ROLLER 2.00X4.00X3.00 OUTSIDE SI60	10	43	45411	CABLE END 0.88IN CABLE	1
21	45523	U-BOLT CLAMP 7/8 IN KP60	4	44	60219	CYLINDER ASM CABLE HOIST (174/182)	1
22	45535	PIN 2.00X27.25 KP60 ROLLER SHAFT	1	45	45358ZP	PIN INSIDE ROLLER W/ZERK KP60	8
23	45552	ROLL PIN 0.38X3.50	3				

Cable Guide Roller - PN 46029

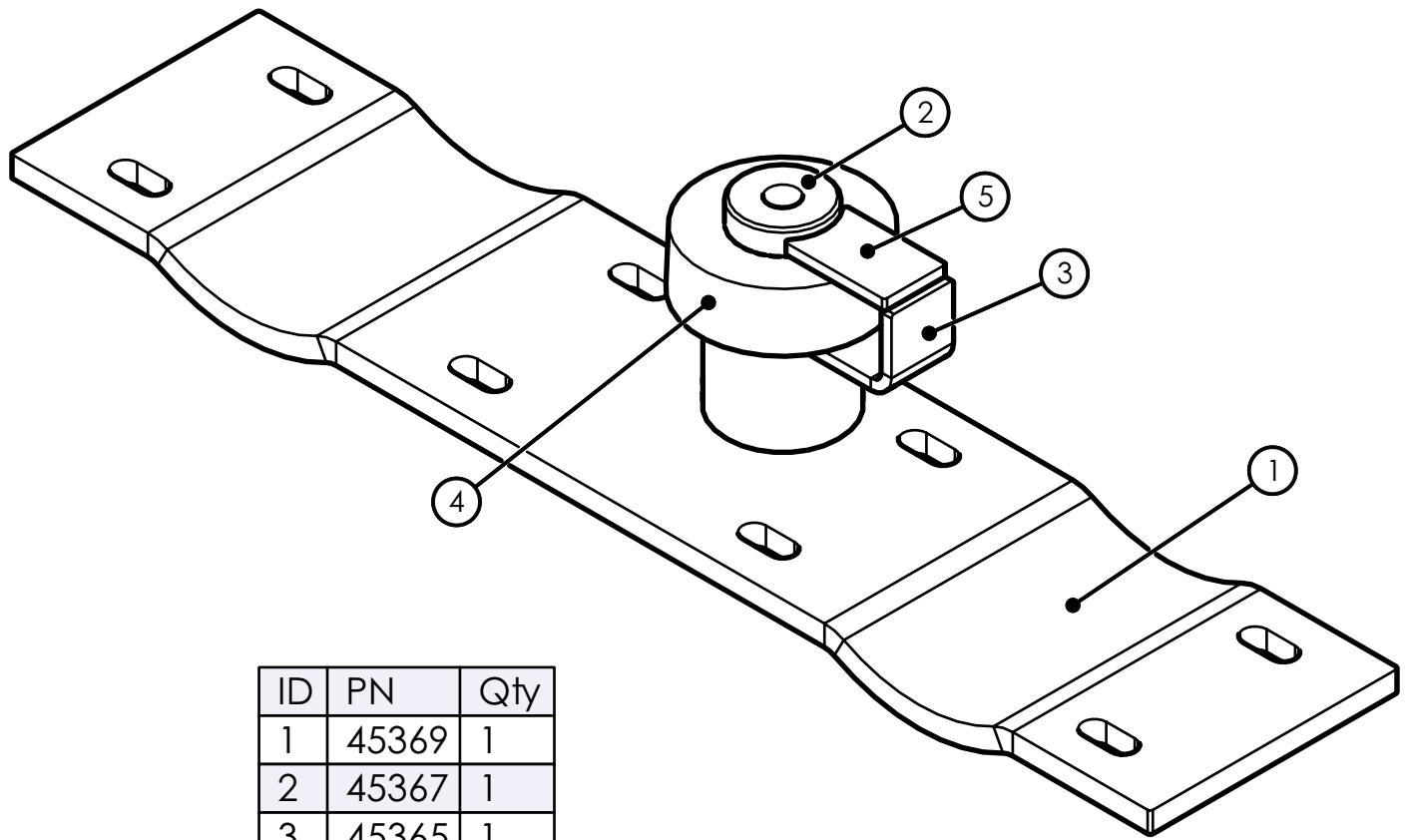

ID	PN	Qty
1	45369	1
2	45367	1
3	45365	1
4	45368	1
5	49600	1

Reeving Cylinder Assembly - PN 60219

174 and 182 Models

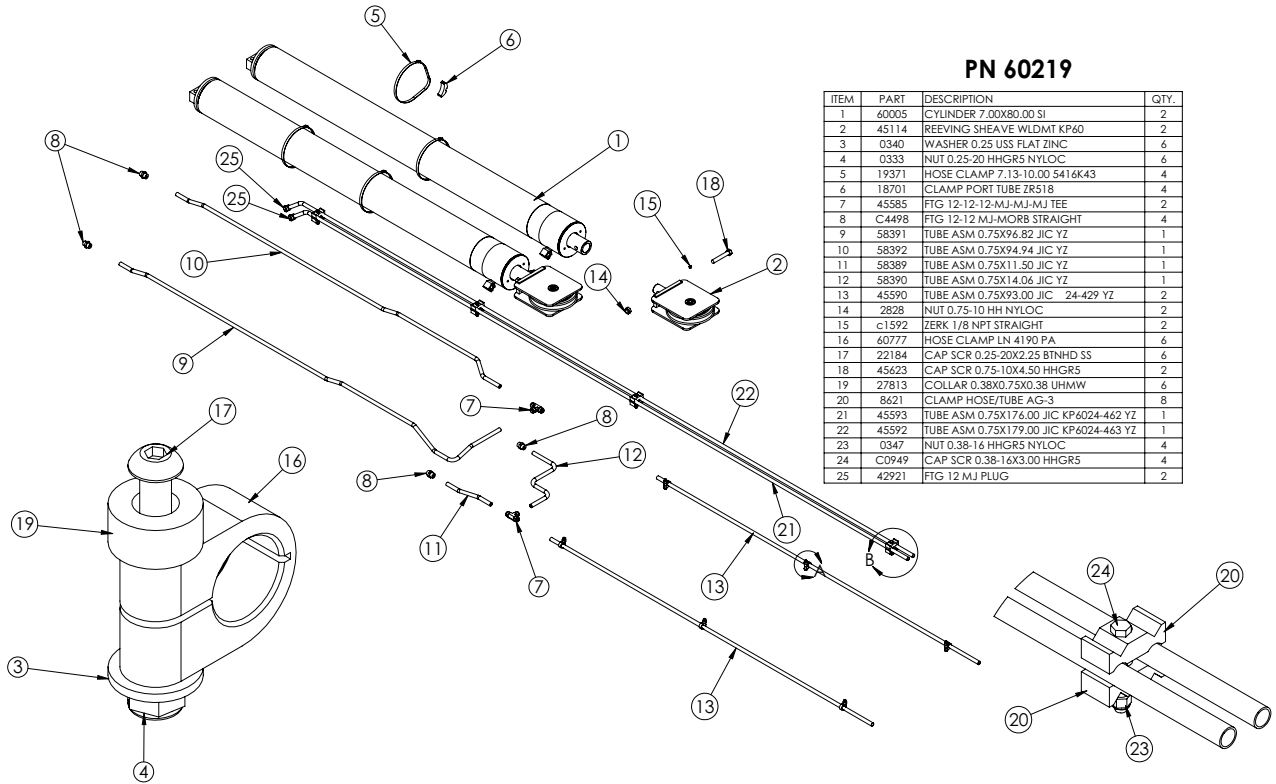

PN 60219

ITEM	PART	DESCRIPTION	QTY.
1	60005	CYLINDER 7.00X80.00 SI	2
2	45114	REEVING SHEAVE WLDMT KP60	2
3	0340	WASHER 0.25 USS FLAT ZINC	6
4	0333	NUT 0.25-20 HHGR5 NYLOC	6
5	19371	HOSE CLAMP 7.13-10.00 5416K43	4
6	18701	CLAMP PORT TUBE ZR518	4
7	45585	FIG 12-12-12-MJ-MJ-MJ TEE	2
8	C4498	FIG 12-12 MJ-MORB STRAIGHT	4
9	58391	TUBE ASM 0.75X96.82 JIC YZ	1
10	58392	TUBE ASM 0.75X94.94 JIC YZ	1
11	58389	TUBE ASM 0.75X11.50 JIC YZ	1
12	58390	TUBE ASM 0.75X14.06 JIC YZ	1
13	45590	TUBE ASM 0.75X93.00 JIC 24-429 YZ	2
14	2828	NUT 0.75-10 HH NYLOC	2
15	c1592	ZERK 1/8 NPT STRAIGHT	2
16	60777	HOSE CLAMP LN 4190 PA	6
17	22184	CAP SCR 0.25-20X2.25 BTNHD SS	6
18	45623	CAP SCR 0.75-10X4.50 HHGR5	2
19	27813	COLLAR 0.38X0.75X0.38 UHMW	6
20	8621	CLAMP HOSE/TUBE AG-3	8
21	45593	TUBE ASM 0.75X176.00 JIC KP6024-462 YZ	1
22	45592	TUBE ASM 0.75X179.00 JIC KP6024-463 YZ	1
23	0347	NUT 0.38-16 HHGR5 NYLOC	4
24	C0949	CAP SCR 0.38-16X3.00 HHGR5	4
25	42921	FIG 12 MJ PLUG	2

Reeving Cylinder Assembly - PN 60221

194 Models

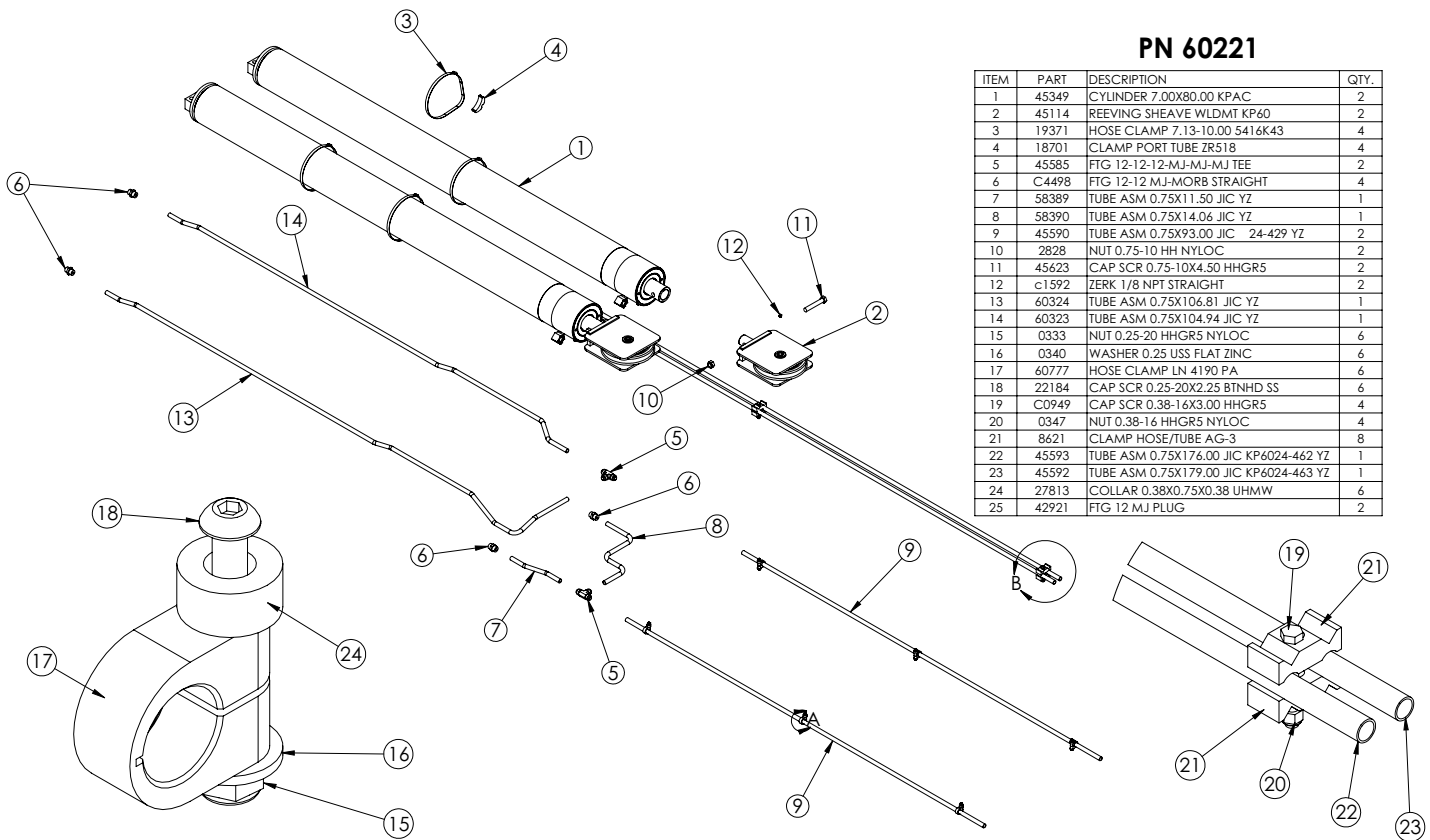

PN 60221

ITEM	PART	DESCRIPTION	QTY.
1	45349	CYLINDER 7.00X80.00 KPAC	2
2	45114	REEVING SHEAVE WLDMT KP60	2
3	19371	HOSE CLAMP 7.13-10.00 5416K43	4
4	18701	CLAMP PORT TUBE ZR518	4
5	45585	FIG 12-12-12-MJ-MJ-MJ TEE	2
6	C4498	FIG 12-12 MJ-MORB STRAIGHT	4
7	58389	TUBE ASM 0.75X11.50 JIC YZ	1
8	58390	TUBE ASM 0.75X14.06 JIC YZ	1
9	45590	TUBE ASM 0.75X93.00 JIC 24-429 YZ	2
10	2828	NUT 0.75-10 HH NYLOC	2
11	45623	CAP SCR 0.75-10X4.50 HHGR5	2
12	c1592	ZERK 1/8 NPT STRAIGHT	2
13	60324	TUBE ASM 0.75X106.81 JIC YZ	1
14	60323	TUBE ASM 0.75X104.94 JIC YZ	1
15	0333	NUT 0.25-20 HHGR5 NYLOC	6
16	0340	WASHER 0.25 USS FLAT ZINC	6
17	60777	HOSE CLAMP LN 4190 PA	6
18	22184	CAP SCR 0.25-20X2.25 BTNHD SS	6
19	C0949	CAP SCR 0.38-16X3.00 HHGR5	4
20	0347	NUT 0.38-16 HHGR5 NYLOC	4
21	8621	CLAMP HOSE/TUBE AG-3	8
22	45593	TUBE ASM 0.75X176.00 JIC KP6024-462 YZ	1
23	45592	TUBE ASM 0.75X179.00 JIC KP6024-463 YZ	1
24	27813	COLLAR 0.38X0.75X0.38 UHMW	6
25	42921	FIG 12 MJ PLUG	2

Chassis Mounted Parts

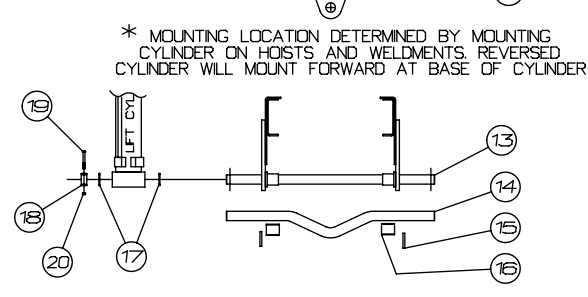
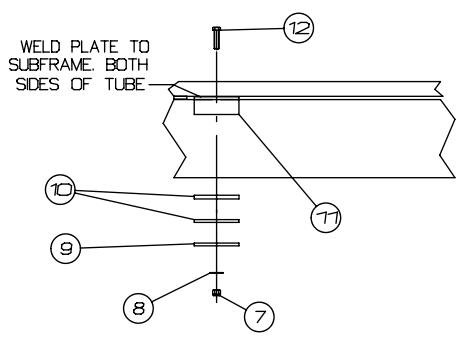
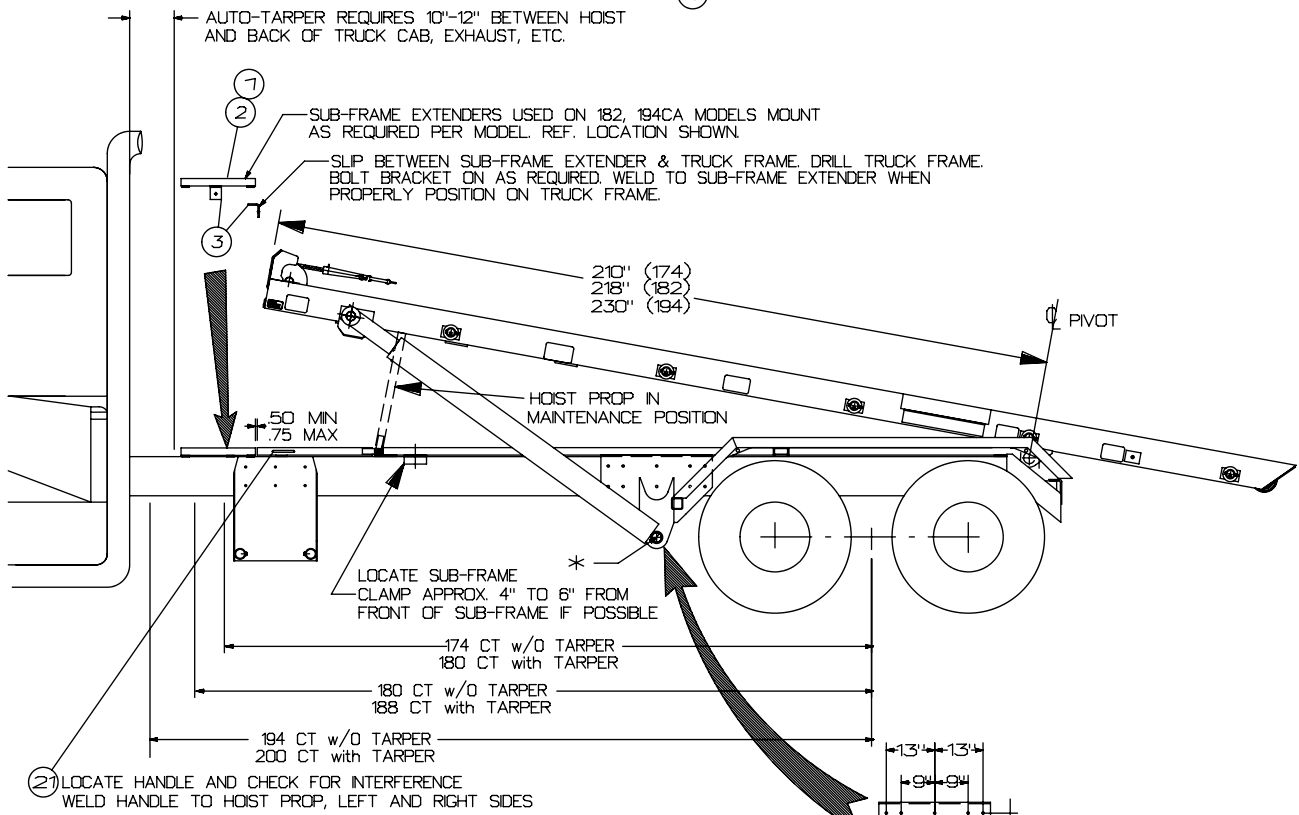
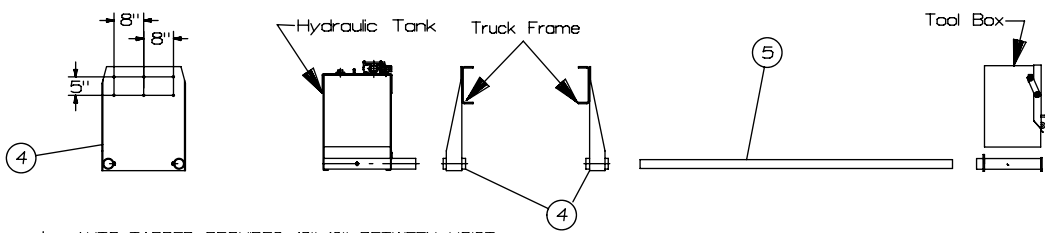
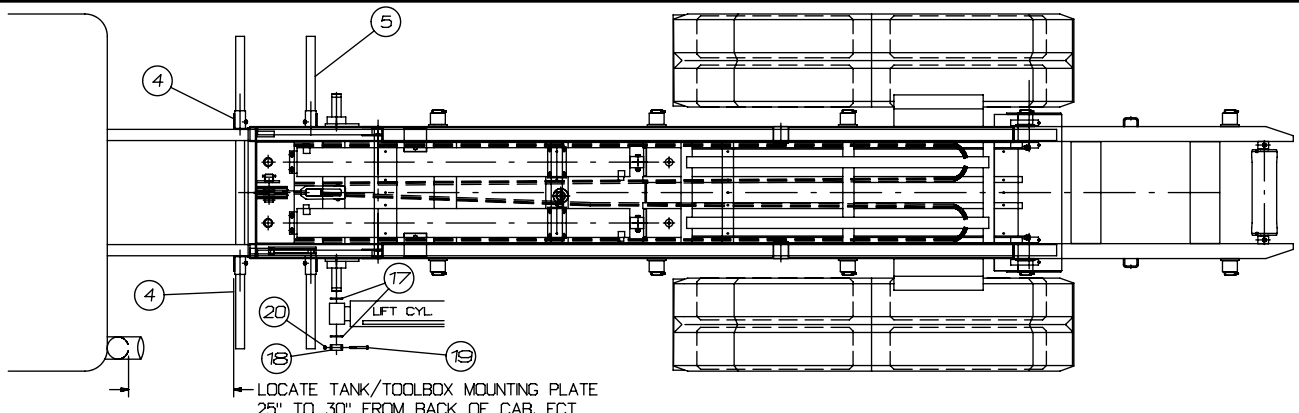

Chassis Mounted Parts

Item	PN	Description	Qty.
1	45054	SUB-FRAME FRONT WELDMENT	1
2	45059	SUB-FRAME FRONT WELDMENT	1
3	46134	PLATE SUBFRAME EXTENDER CLAMP	2
4	46062	MOUNTING BRACKET RSRVR SI60	2
5	46063	TUBE RSRVR MOUNTING SI60	2
6	45600	MOUNT BRKT TRUCK FRAME LUG SI60	2
7	47089	NUT 0.63-18 HHGR5 NYLOC	2
8	C1038	WASHER 0.63 USS FLAT ZINC	2
9	45762	PLATE SUBFRAME CLAMP BTTM SI60	2
10	45761	PLATE SUBFRAME SHIM SI60	4
11	45760	PLATE SUBFRAME CLAMP SI60	2
12	47088	CAP SCR 0.63-18X2.50 HHGR5	2
13	47531	PIN PIVOT	1
14	45144	PIN 2.50 KP60 DROP SHAFT	1
15	45758	FLAT 0.50X4.00X0.75	4
16	45757	TUBE 3.00X3.00X.19WX3.50	2
17	47852	WASHER FLAT 2.56IDX3.25ODX0.25 THCK	8
18	45756	COLLAR 2.51X3.25X1.50 W/HOLE	4
19	0507	CAP SCR 0.50-13X4.50 HHGR5	4
20	C6106	NUT 0.50-13 HHGR5 NYLOC	4
21	45597	HANDLE PROP SI60	2

Mounting Kit (Forward Mount) - PN 55261

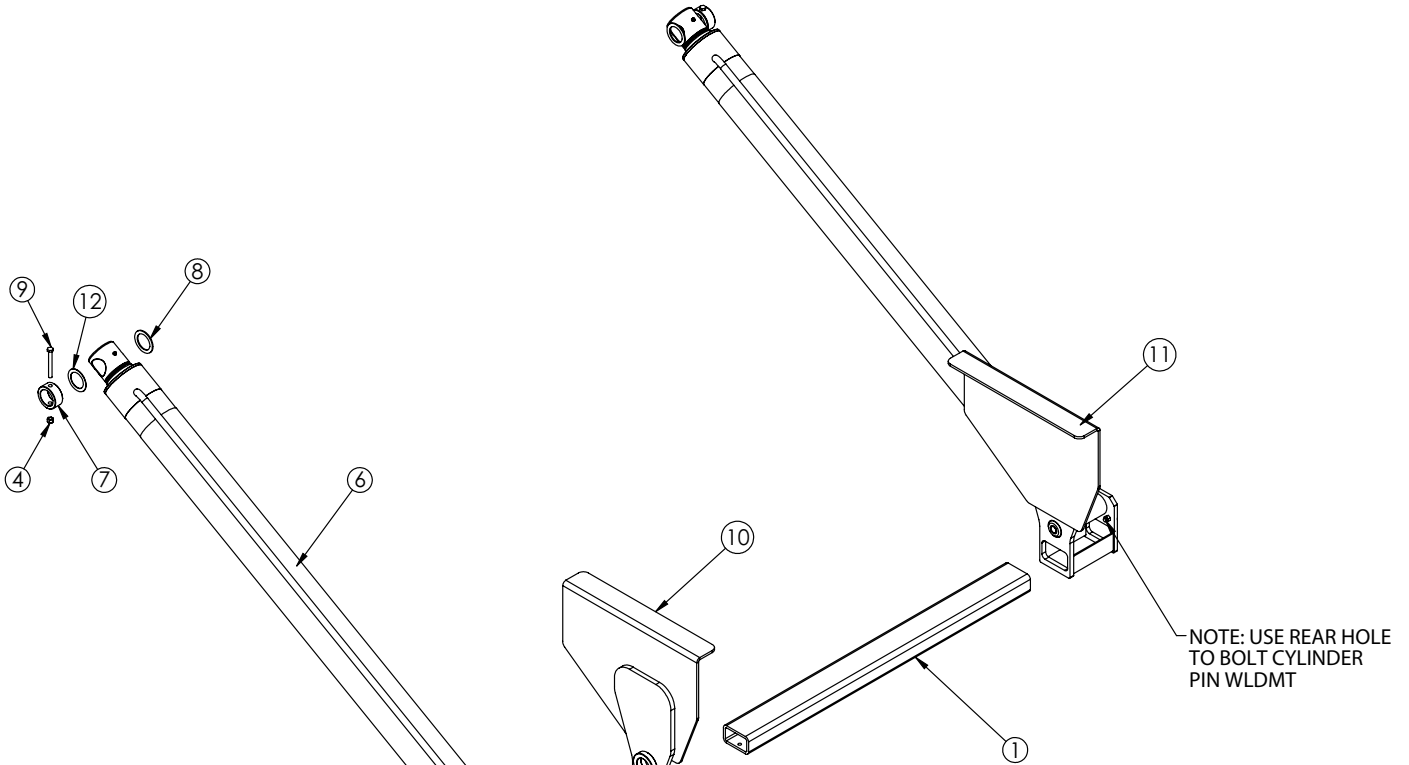

PN 55261

ITEM	PART	DESCRIPTION	QTY.
1	49997	TUBE 5.00X3.00X0.38WX56.00	1
2	49995ZP	PIN WLDMT CYL MNT CABLE75	2
3	0500	CAP SCR 0.50-13X1.75 HHGR5	2
4	C6106	NUT 0.50-13 HHGR5 NYLOC	4
5	0352	WASHER 0.50 USS FLAT ZINC	2
6	55262	CYLINDER ASM 6.00X72.00 LIFT CABLE75 MNT	2
7	45756PC	COLLAR 2.51X3.50X1.50 W/HOLE	2
8	1593	MACHY WASHER 2.50ID 10GA	2
9	0507	CAP SCR 0.50-13X4.50 HHGR5	2
10	52889PC	CYL MNT WLDMT SS SI75 HP OFFSET	1
11	52892PC	CYL MNT WLDMT SS SI75 HP	1
12	1583	MACHY WASHER 2.50ID 14GA	2

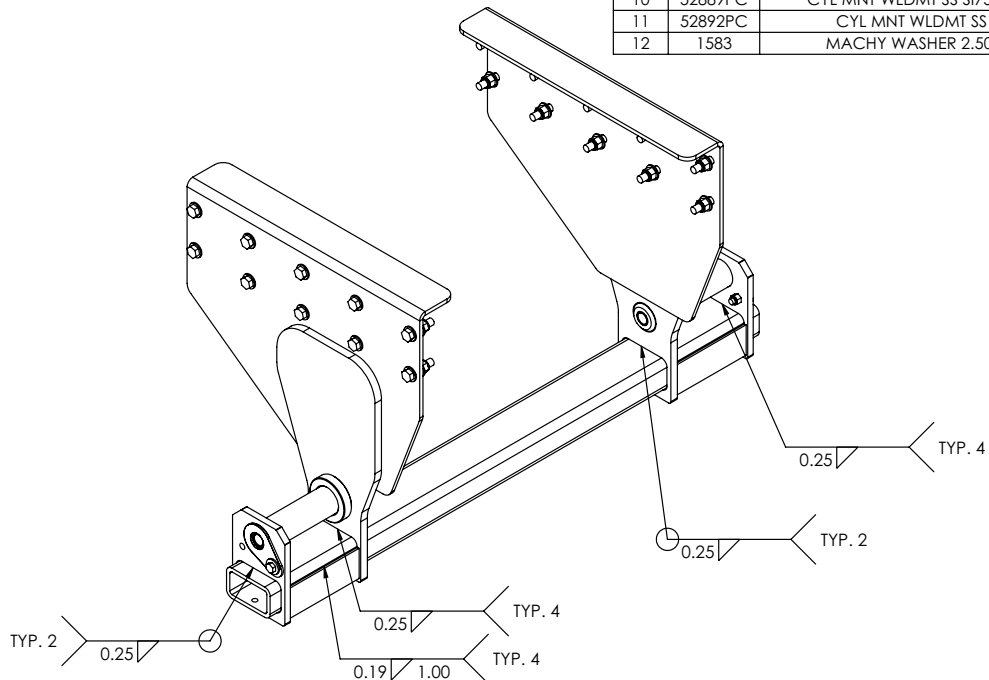

Mounting Kit (Reverse Mount) - PN 56094

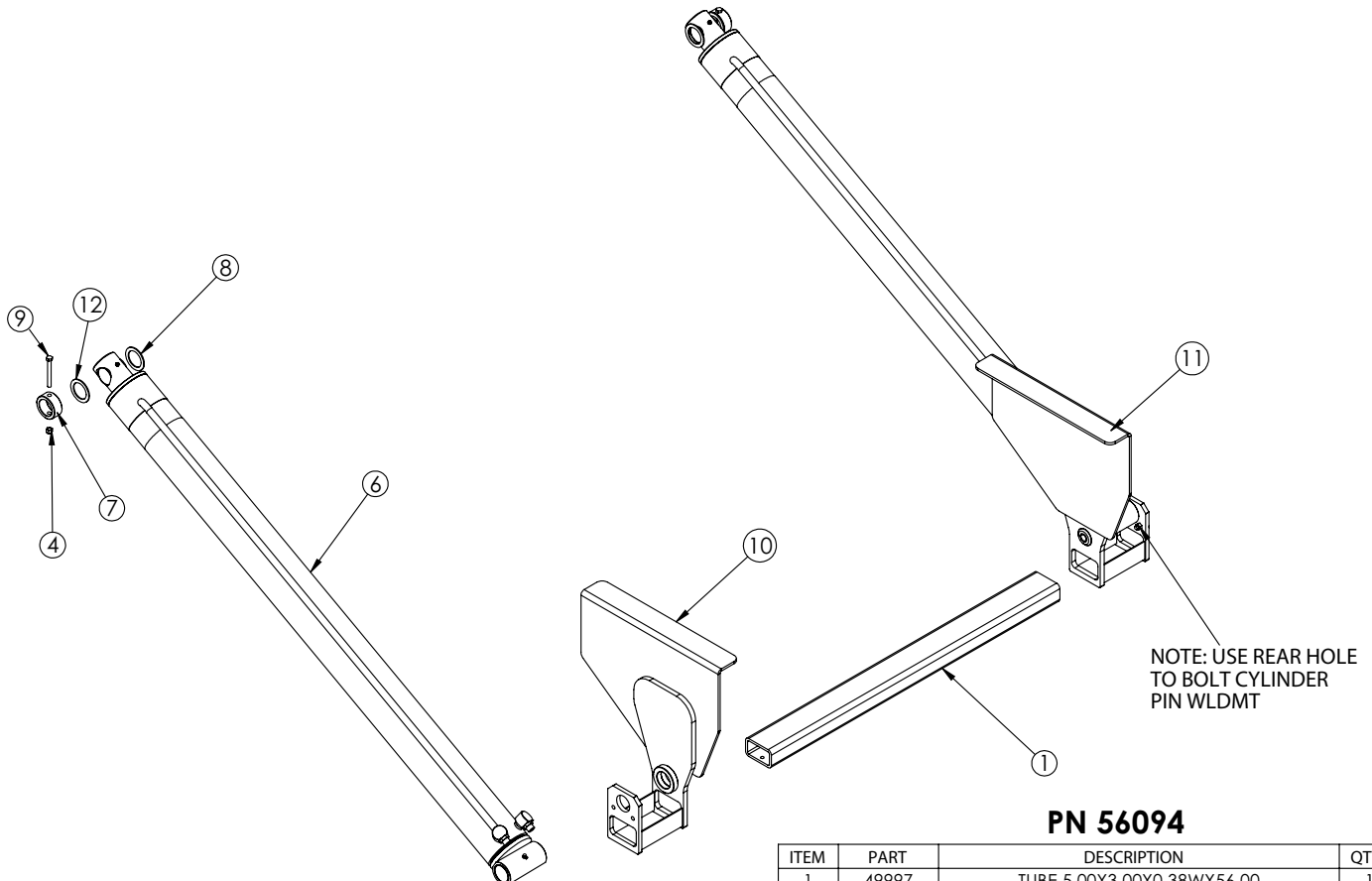

PN 56094

ITEM	PART	DESCRIPTION	QTY.
1	49997	TUBE 5.00X3.00X0.38WX56.00	1
2	49995ZP	PIN WLDMT CYL MNT CABLE75	2
3	0500	CAP SCR 0.50-13X1.75 HHGR5	2
4	C6106	NUT 0.50-13 HHGR5 NYLOC	4
5	0352	WASHER 0.50 USS FLAT ZINC	2
6	55262	CYLINDER ASM 6.00X72.00 LIFT CABLE75 MNT	2
7	45756PC	COLLAR 2.51X3.50X1.50 W/HOLE	2
8	1593	MACHY WASHER 2.50ID 10GA	2
9	0507	CAP SCR 0.50-13X4.50 HHGR5	2
10	52889PC	CYL MNT WLDMT SS SI75 HP OFFSET	1
11	52892PC	CYL MNT WLDMT SS SI75 HP	1
12	1583	MACHY WASHER 2.50ID 14GA	2

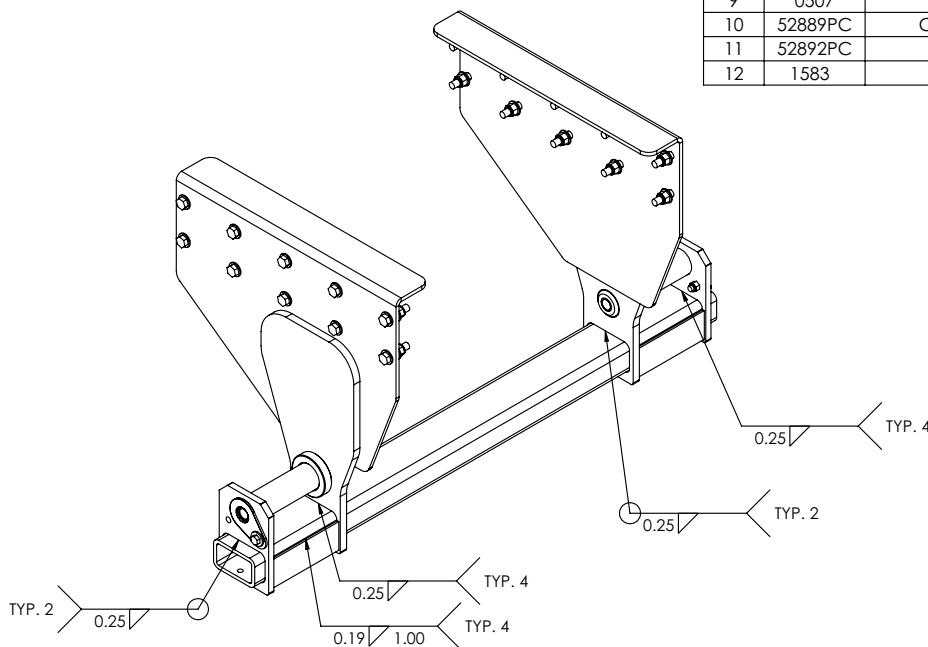

Mounting Kit (Telescopic) - PN 55265

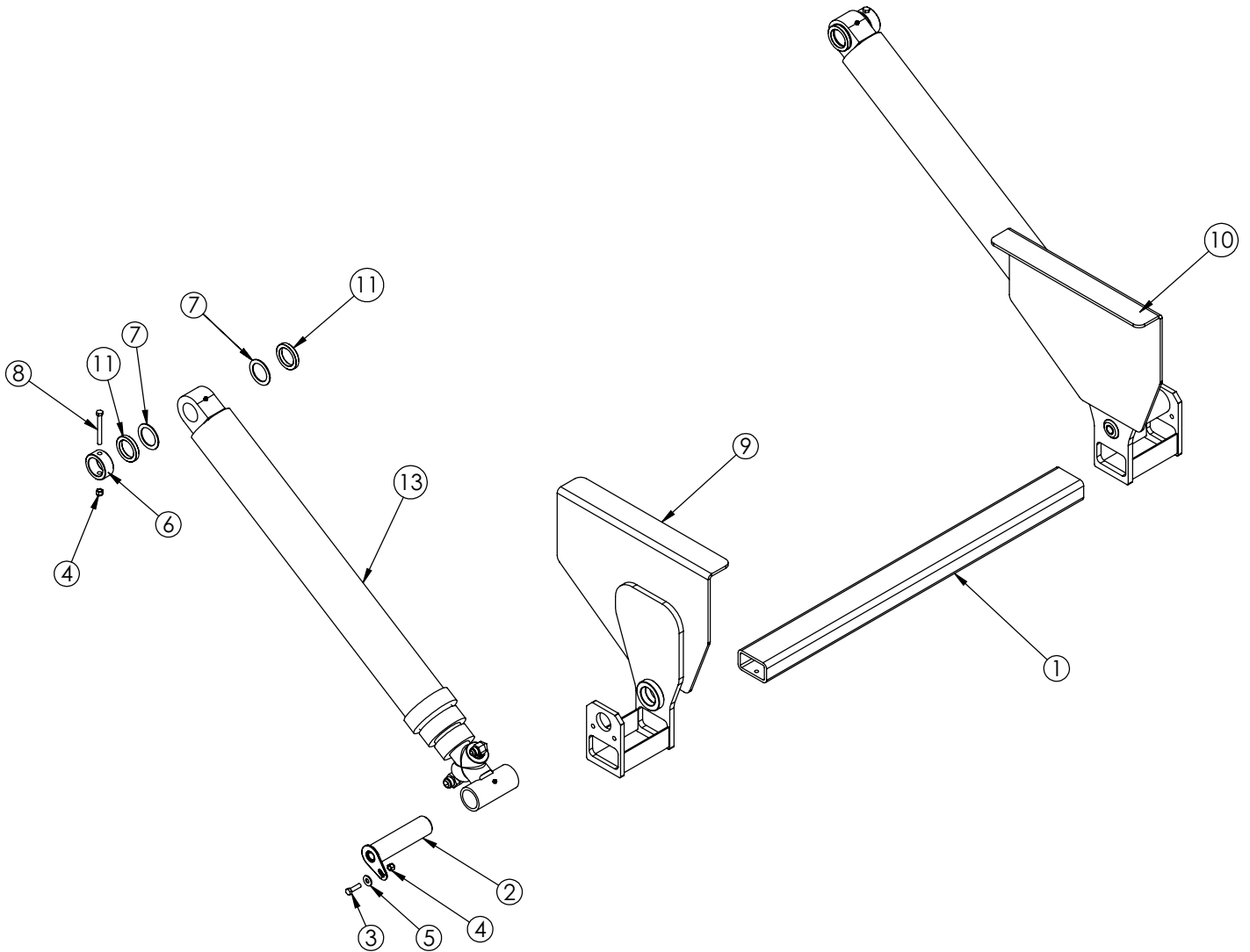

PN 55265

ITEM	PART	DESCRIPTION	QTY.
1	49997	TUBE 5.00X3.00X0.38WX56.00	1
2	49995ZP	PIN WLDMT CYL MNT CABLE75	2
3	0500	CAP SCR 0.50-13X1.75 HHGR5	2
4	C6106	NUT 0.50-13 HHGR5 NYLOC	4
5	0352	WASHER 0.50 USS FLAT ZINC	2
6	45756PC	COLLAR 2.51X3.50X1.50 W/HOLE	2
7	1593	MACHY WASHER 2.50ID 10GA	4
8	0507	CAP SCR 0.50-13X4.50 HHGR5	2
9	52889PC	CYL MNT WLDMT SS SI75 HP OFFSET	1
10	52892PC	CYL MNT WLDMT SS SI75 HP	1
11	60794	COLLAR 2.51X3.50X.50 UHMW	4
12	51078	CYLINDER ASM 5.50X185.75 TELO KPAC	1
13	51078	CYLINDER ASM 5.50X185.75 TELO KPAC	1

Cab Guard - PN 47263

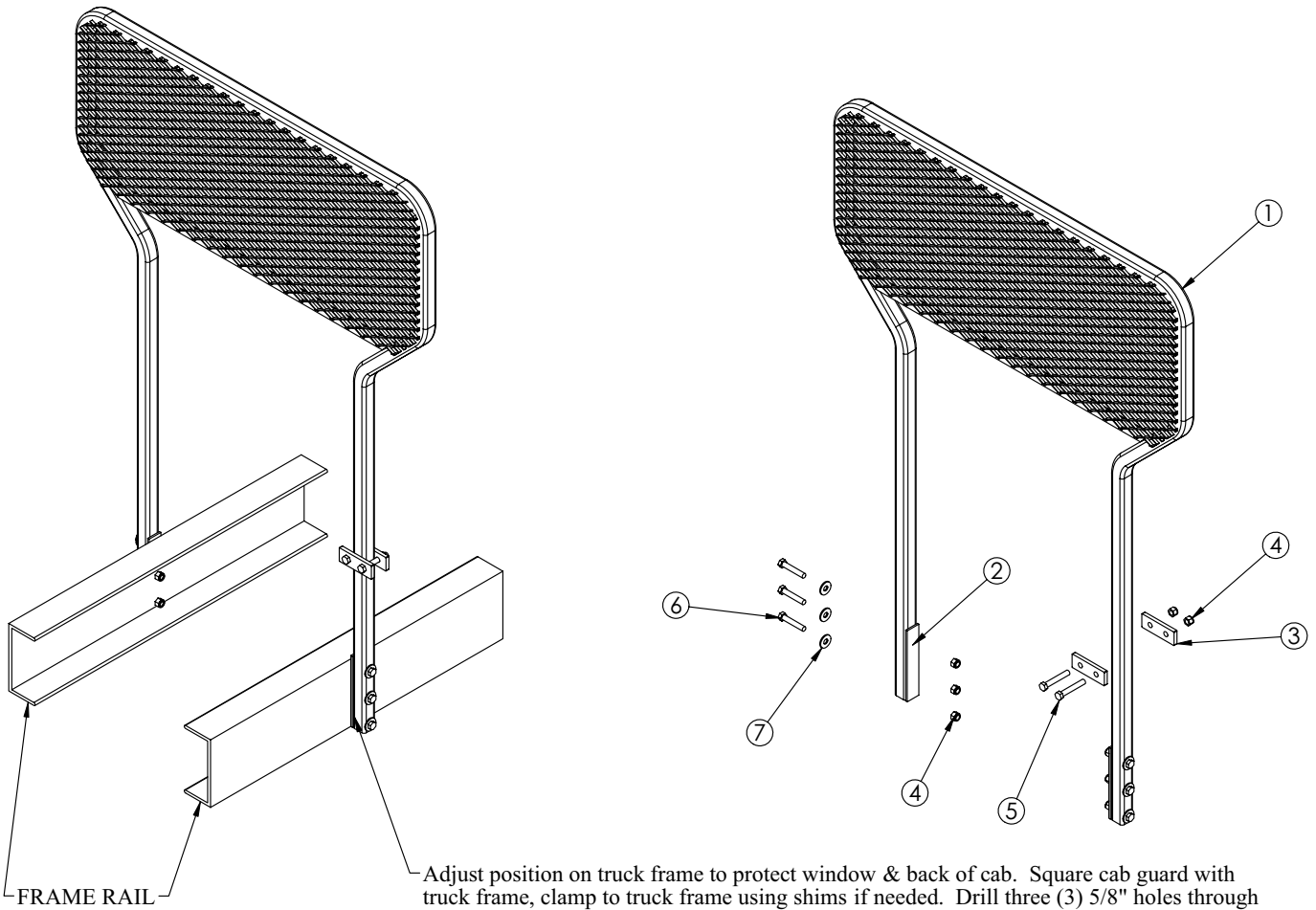

Adjust position on truck frame to protect window & back of cab. Square cab guard with truck frame, clamp to truck frame using shims if needed. Drill three (3) 5/8" holes through cab guard and truck frame approx. 3" apart (both sides). Bolt cab guard to truck frame.

PN 47263

ITEM	PART	DESCRIPTION	QTY.
1	47262	CAB GUARD WLDMT KP60	1
2	47265	FLAT 0.25X2.00X10.50	2
3	47264	CLAMP BAR CAB GUARD KP60	2
4	2826	NUT 0.63-11 HHGR5 NYLOC	8
5	2827	CAP SCR 0.63-11X4.00 HHGR5	2
6	C0964	CAP SCR 0.63-11X3.50 HHGR5	6
7	C1038	WASHER 0.63 USS FLAT ZINC	6

Under Body Tool Box - PN 46579

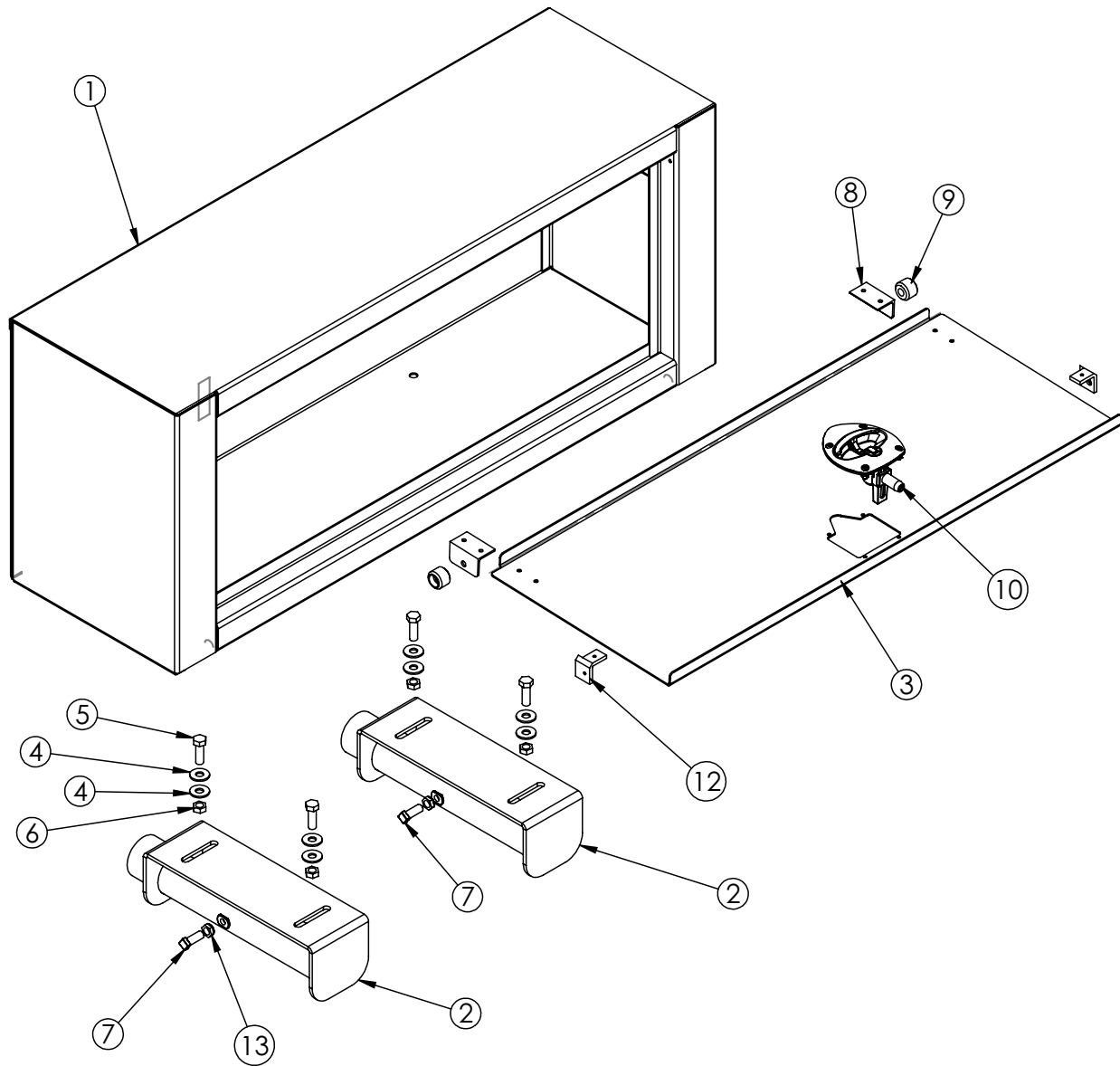

PN 46579

ITEM	PART	DESCRIPTION	QTY.
1	46580	UBTB WLDMT OH 20X48X15	1
2	46578PC	UBTB MNT WLDMT 15.00D-KPAC	2
3	46577	DOOR OH 16.19X40.06 VECTOR SPT-KPAC	1
4	0352	WASHER 0.50 USS FLAT ZINC	8
5	0359	CAP SCR 0.50-13X1.50 HHGR5	4
6	C6106	NUT 0.50-13 HHGR5 NYLOC	4
7	46590	CAP SCR 0.50X1.50 SQ HD CP SS	2
8	22045	BRKT ROLLER MOUNT OH DOOR	2
9	4110	ROLLER OH DOOR UHMW	2
10	23763	LATCH ASM VECTOR SGL PT	1
11	4183	ANGLE UHMW RH 1.50X1.50X0.25X1.25	1
12	4167	ANGLE UHMW LH 1.50X1.50X0.25X1.25	1
13	16333	NUT 0.50-13 HH JAM NYLOC	2

Reservoir Assembly - PN 46133

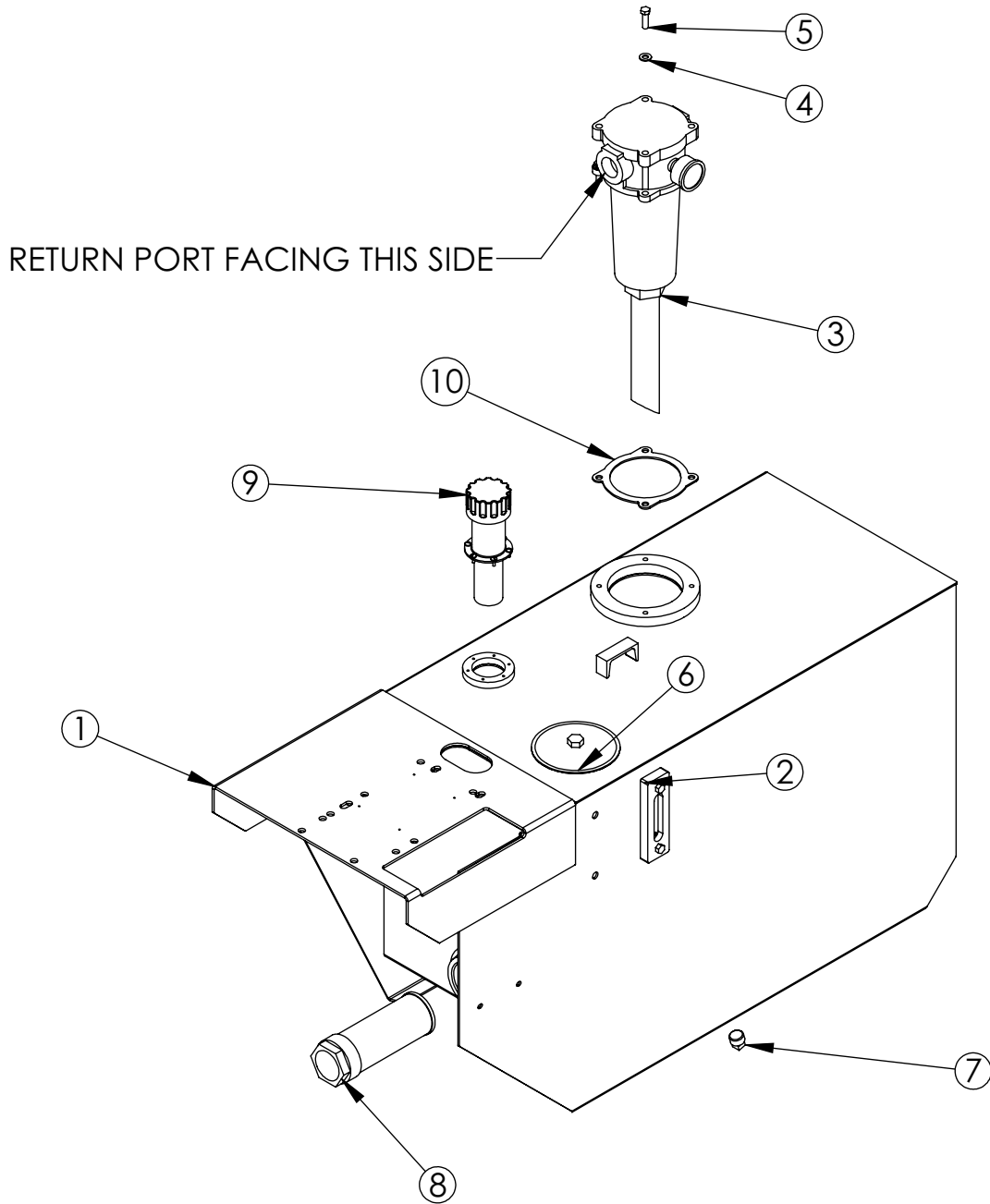

PN 46133

ITEM	PART	DESCRIPTION	QTY.
1	46130	RSRVR WLDMT 60GAL KP60	1
2	15463	THERMO SIGHT GAUGE	1
3	45075	FILTER K-PAC TANK TOP	1
4	C6353	WASHER 0.38 SAE FLAT YELLOW GR8	4
5	0335	CAP SCR 0.38-16X1.25 HHGR5	4
6	15464	TANK COVER	1
7	C4845	PLUG 0.75 NPT SQ HD BLK	1
8	C6327	FILTER STRAINER 35GAL TF-2030	1
9	57739	CAP FILL ASM W/3" NECK 1PSI	1
10	58396	GASKET RG-11 TANK TOP FILTER	1

2 Section Valve Bank Reservoir - PN 45710

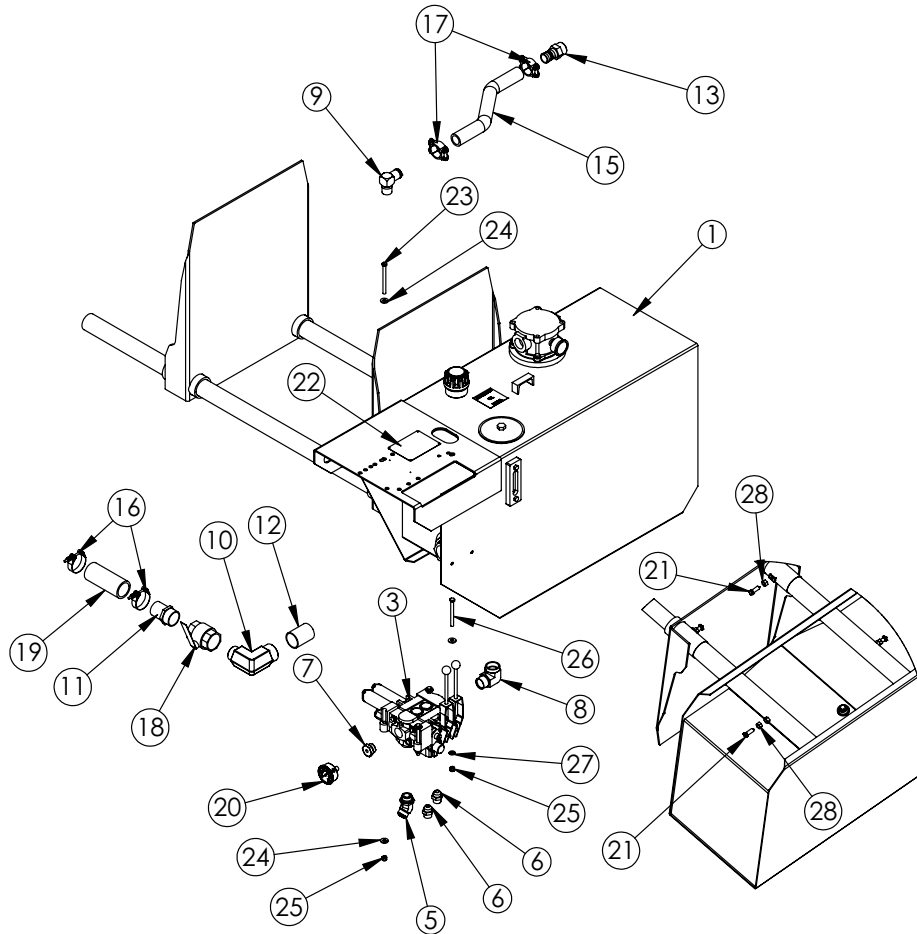

PN 45710

ITEM	PART	DESCRIPTION	Default/Qty
1	46133	RSRVR ASM 60GAL KP60	1
2	46062	MOUNTING BRACKET RSRVR KP60	2
3	59841	VB 2-SECT VA20 KIT	1
4	8176	SCREW DRIVE #4X0.31 RND HD U ZINC	4
5	45802	FTG 16-16 MJ-MAORB 45	1
6	C4498	FTG 12-12 MJ-MORB STRAIGHT	4
7	85400	FTG 16-4 MORB-FORB STRAIGHT REDUCER	1
8	9758	FTG 20-20 MAORB-FP 90	1
9	8617	FTG 20-20 HB-MP 90	1
10	D0652	FTG 32-32 MP-FP STREET ELBOW 90 BLK	1
11	C4730	FTG 32-32 MP-HB STRAIGHT	1
12	7285	FTG 32-32X3.00 MP-MP NIPPLE STRAIGHT BLK	1
13	C2282	FTG 1.25 NPT TO 1.25 BARB	1
14	46063	TUBE RSRVR MOUNTING KP60	2
15	45831	HOSE 1.25X19.00 KP60	1
16	c4819	HOSE CLAMP 2.00	2
17	C1123	HOSE CLAMP 88 DB-20	2
18	C4750	VALVE BALL 2.00	1
19	17766	HOSE SUCT 2.00 10FT	1
20	6397	GAUGE OIL LF 2.5 0-5000 CBM	1
21	46590	CAP SCR 0.50X1.50 SQ HD CP SS	6
22	67745	PLATE SERIAL VALVE PLATE KP60 KPAC#74-289	1
23	C0954	CAP SCR 0.38-16X4.50 HHGR5	3
24	0346	WASHER 0.38 USS FLAT	7
25	0347	NUT 0.38-16 HHGR5 NYLOC	4
26	C0953	CAP SCR 0.38-16X4.00 HHGR5	1
27	C6353	WASHER 0.38 SAE FLAT YELLOW GR8	1
28	0537	NUT 0.50-13 HHGR5	6

3 Section Valve Bank Reservoir - PN 46642

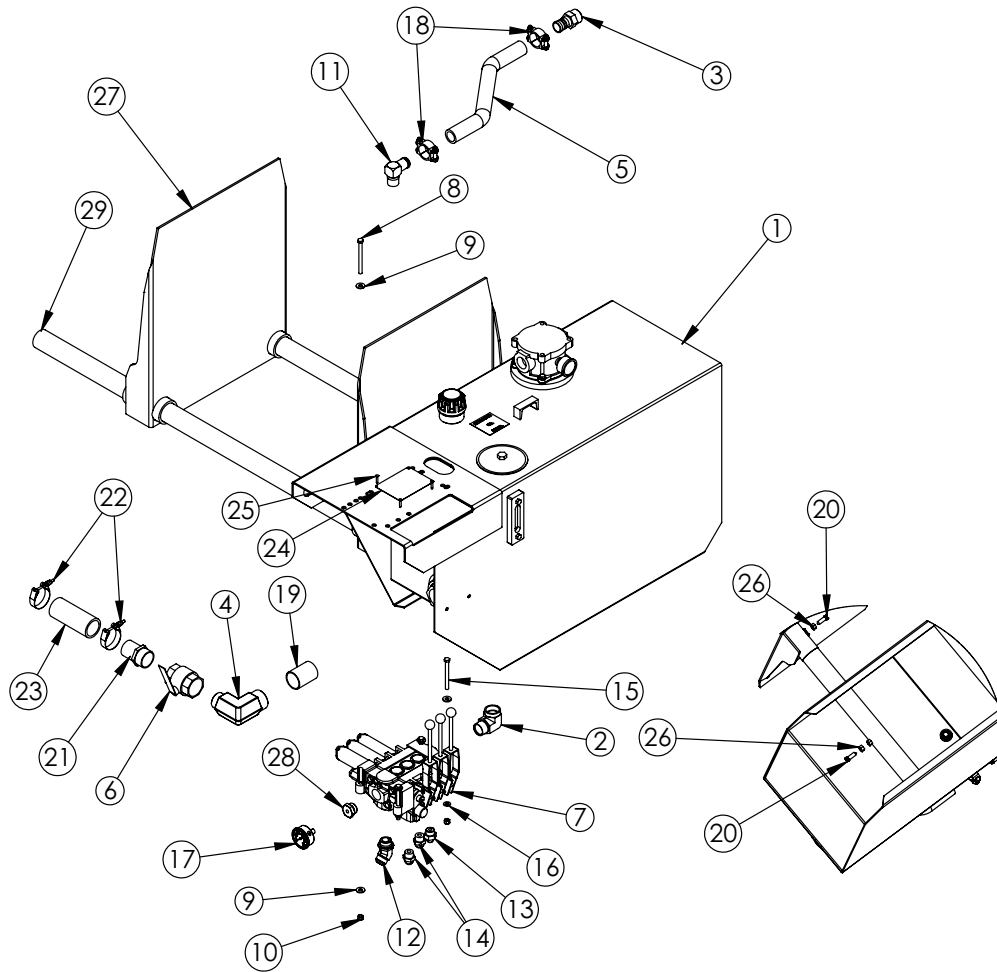

PN 46642

ITEM	PART	DESCRIPTION	QTY
1	46133	RSVR ASM 60GAL KP60	1
2	9758	FTG 20-20 MAORB-FP 90	1
3	C2282	FTG 1.25 NPT TO 1.25 BARB	1
4	D0652	FTG 32-32 MP-FP STREET ELBOW 90 BLK	1
5	45831	HOSE 1.25X19.00 KP60	1
6	C4750	VALVE BALL 2.00	1
7	59843	VB 3-SECT VA20 KIT	1
8	C0954	CAP SCR 0.38-16X4.50 HHGR5	3
9	0346	WASHER 0.38 USS FLAT	7
10	0347	NUT 0.38-16 HHGR5 NYLOC	4
11	8617	FTG 20-20 HB-MP 90	1
12	45802	FTG 16-16 MJ-MAORB 45	1
13	D1189	FTG 8-12 MJ-MORB STRAIGHT	2
14	C4498	FTG 12-12 MJ-MORB STRAIGHT	4
15	C0953	CAP SCR 0.38-16X4.00 HHGR5	1
16	C6353	WASHER 0.38 SAE FLAT YELLOW GR8	1
17	6397	GAUGE OIL LF 2.5 0-5000 CBM	1
18	C1123	HOSE CLAMP 88 DB-20	2
19	7285	FTG 32-32X3.00 MP-MP NIPPLE STRAIGHT BLK	1
20	46590	CAP SCR 0.50X1.50 SQ HD CP SS	6
21	C4730	FTG 32-32 MP-HB STRAIGHT	1
22	c4819	HOSE CLAMP 2.00	2
23	17766	HOSE SUCT 2.00 10FT	1
24	67746	PLATE SERIAL VALVE PLATE SI60 3SEC	1
25	8176	SCREW DRIVE #4X0.31 RND HD U ZINC	4
26	0537	NUT 0.50-13 HHGR5	6
27	46062	MOUNTING BRACKET RSRVR KP60	2
28	85400	FTG 16-4 MORB-FORB STRAIGHT REDUCER	1
29	46063	TUBE RSRVR MOUNTING KP60	2

Reservoir Mounting Bracket for PN 45710

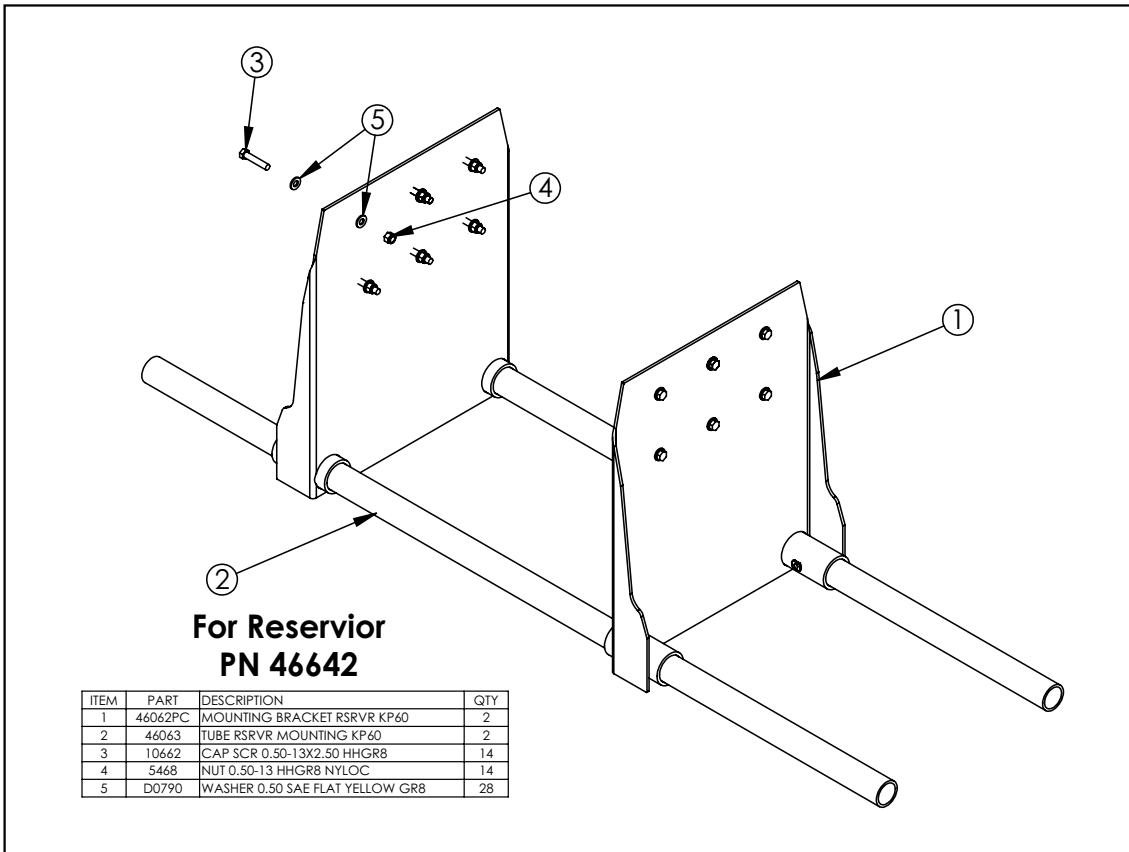
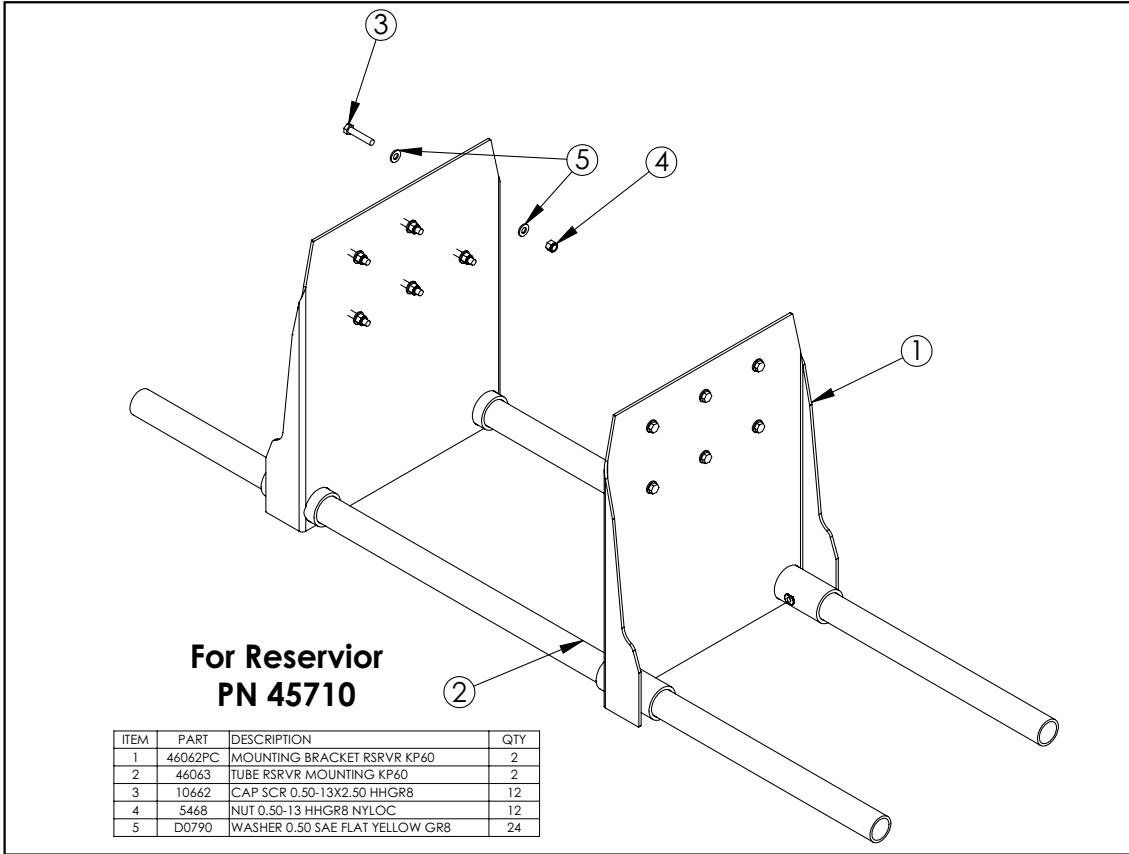

Standard Lighted Bumper - PN 45887

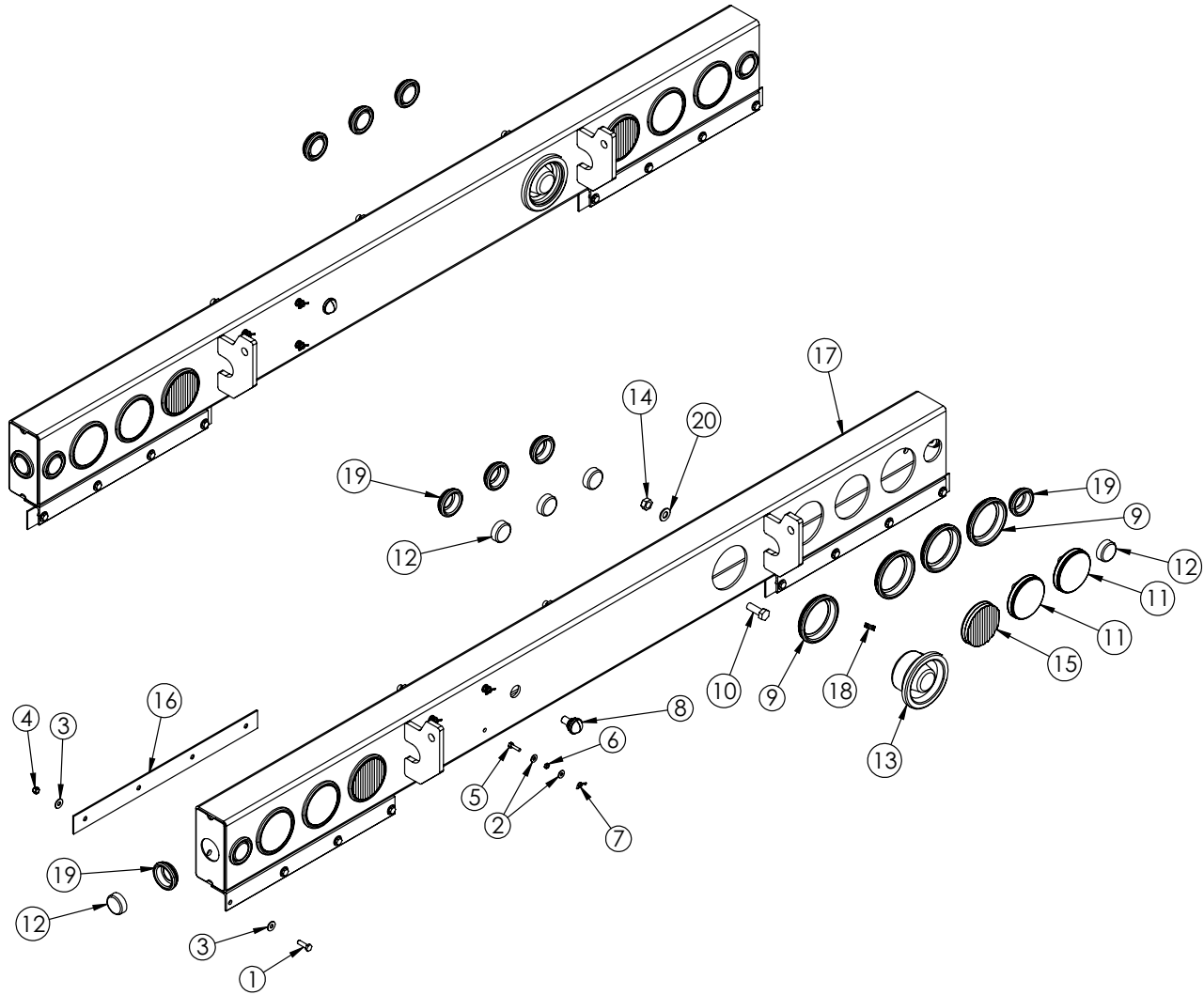

PN 45887

ITEM	PART	DESCRIPTION	QTY.
1	0335	CAP SCR 0.38-16X1.25 HHGR5	8
2	0340	WASHER 0.25 FLAT	8
3	0346	WASHER 0.38 FLAT	16
4	0347	NUT 0.38-16 HH NYLOC	8
5	0480	CAP SCR 0.25-20X1.00 HHGR5	4
6	0533	NUT 0.25-20 HH	4
7	0654	NUT 0.25-20 WING	4
8	2320	LICENSE PLATE LIGHT ROUND 430 W	1
9	10334	GROMMET 4.00 ROUND LAMP (PETERSON)	7
10	11693	CAP SCR 0.63-11X1.75 HHGR8	6
11	13143	LIGHT STOP/TURN/TAIL 4 RND LED	4
12	13145	LIGHT CLEARANCE RED RND 2 LED	7
13	18742	BACKUP ALARM ACORN 97 DECIBAL	1
14	24868	NUT 0.63-11 HHGR8 NYLOCK ZY	6
15	27626	LIGHT BACKUP LED 62391	2
16	45039PC	PLATE MUD FLAP BACKING 43"FENDER KP	2
17	45812	BUMPER WLDMT STANDARD KP60	1
18	C0073	TERML 16-14 BLUE BUTT WATER TIGHT	2
19	C4862	GROMMET FOR 2 CLEARANCE 30700	7
20	C5902	WASHER 0.63 SAE FLAT YELLOW GR8	12

Pintle Bumper - PN 46818

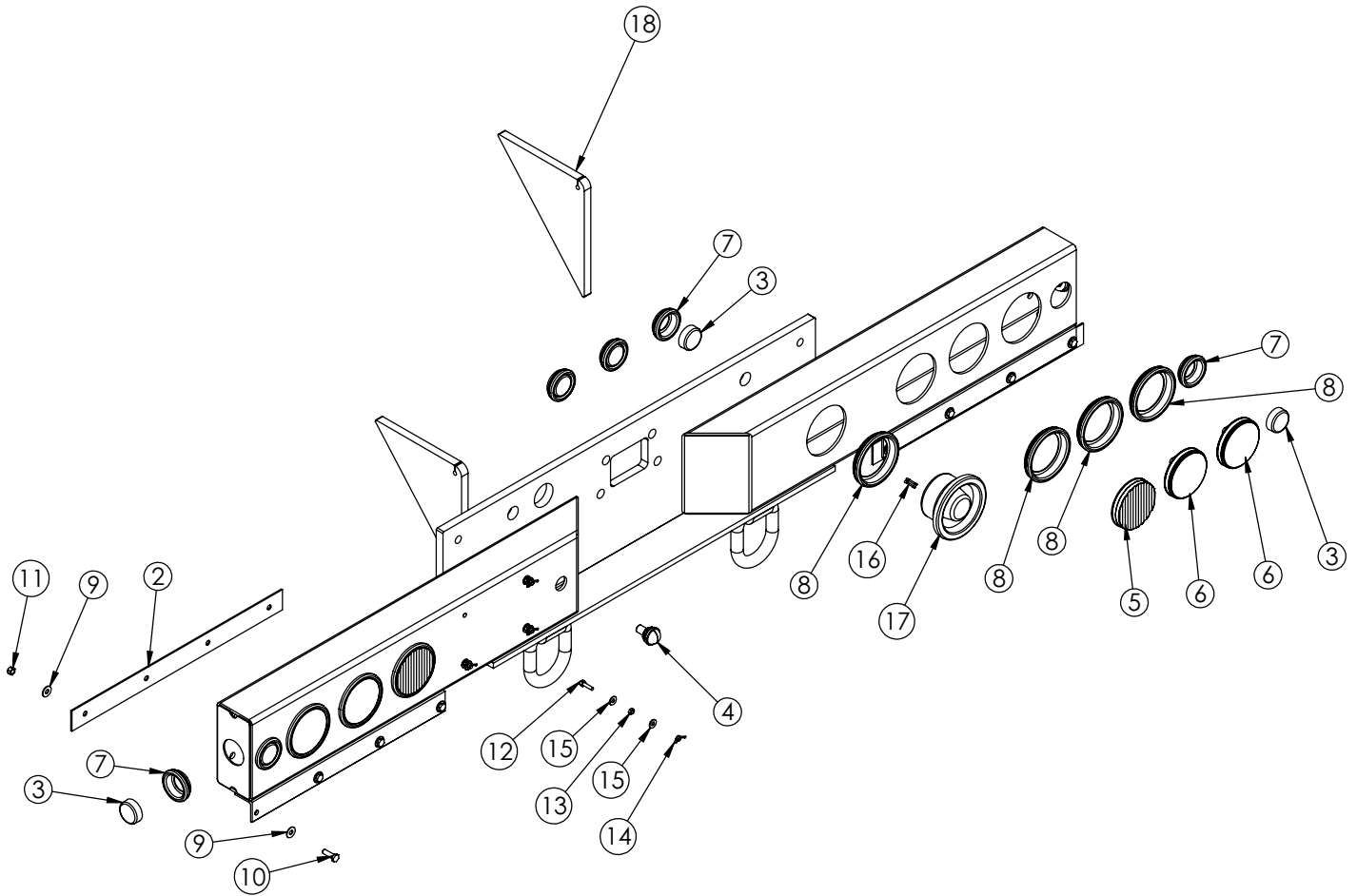

PN 46818

ITEM	PART	DESCRIPTION	QTY.
1	62293	BUMPER WLDMT 90K PINTLE TARPER	1
2	45039PC	PLATE MUD FLAP BACKING 43"FENDER KP	2
3	13145	LIGHT CLEARANCE RED RND 2 LED	7
4	2320	LICENSE PLATE LIGHT ROUND 430 W	1
5	27626	LIGHT BACKUP LED 62391	2
6	13143	LIGHT STOP/TURN/TAIL 4 RND LED	4
7	C4862	GROMMET FOR 2 CLEARANCE 30700	7
8	10334	GROMMET 4.00 ROUND LAMP (PETERSON)	7
9	0346	WASHER 0.38 FLAT	16
10	0335	CAP SCR 0.38-16X1.25 HHGR5	8
11	0347	NUT 0.38-16 HH NYLOC	8
12	0480	CAP SCR 0.25-20X1.00 HHGR5	4
13	0533	NUT 0.25-20 HH	4
14	0654	NUT 0.25-20 WING	4
15	0340	WASHER 0.25 FLAT	8
16	C0073	TERML 16-14 BLUE BUTT WATER TIGHT	2
17	18742	BACKUP ALARM ACORN 97 DECIBAL	1
18	46822	GUSSET 11.50X10.00X.75 PINTLE BUMPER	2

ICC Wide Bumper - PN 53397

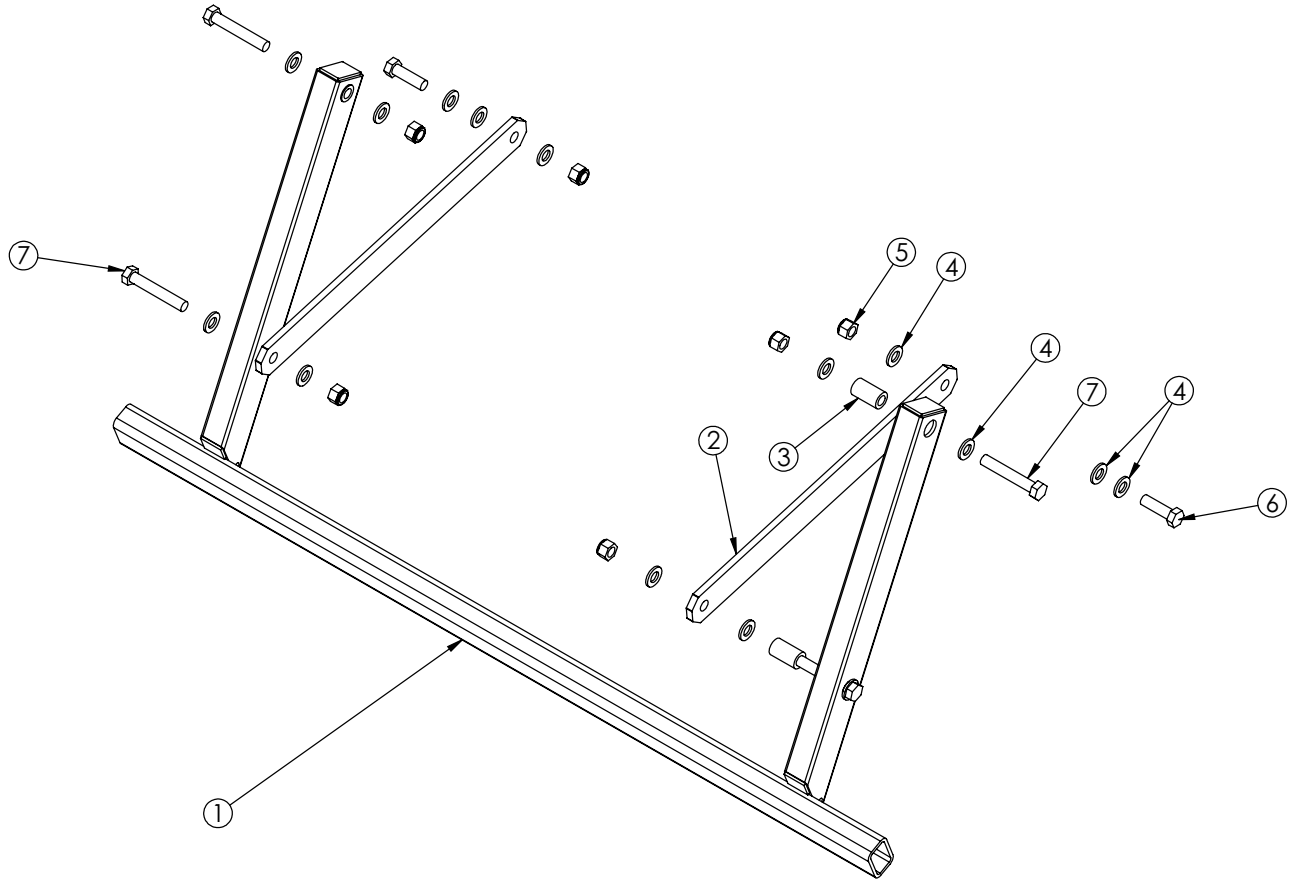

PN 53397

ITEM	PART	DESCRIPTION	QTY.
1	53398	BUMPER WLDMT ICC WIDE	1
2	45813PC	PLATE LINK ICC BUMPER	2
3	45815	SPACER 1.25ODX0.75IDX2.16	4
4	C6219	WASHER 0.75 SAE FLAT YELLOW GR8	16
5	C0538	NUT 0.75-10 HHGR8 NYLOC	6
6	58681	CAP SCR 0.75-10X2.50 HHGR8	2
7	5841	CAP SCR 0.75-10X4.50 HHGR8	4

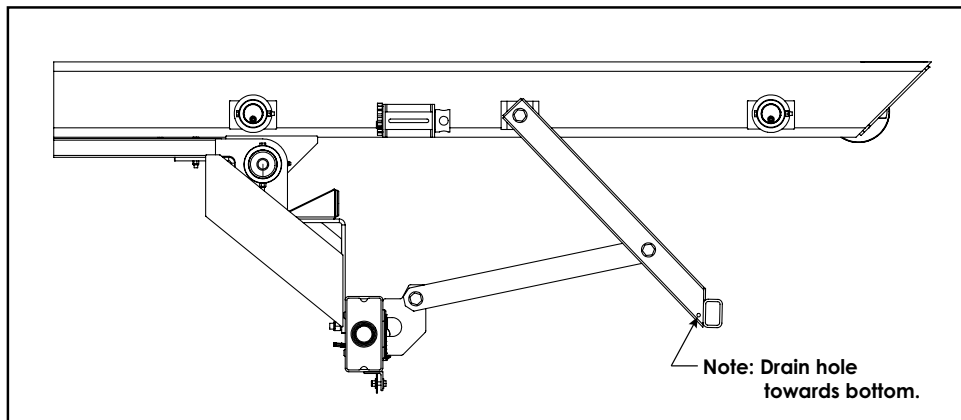

ICC Heavy Duty Bumper - PN 46809

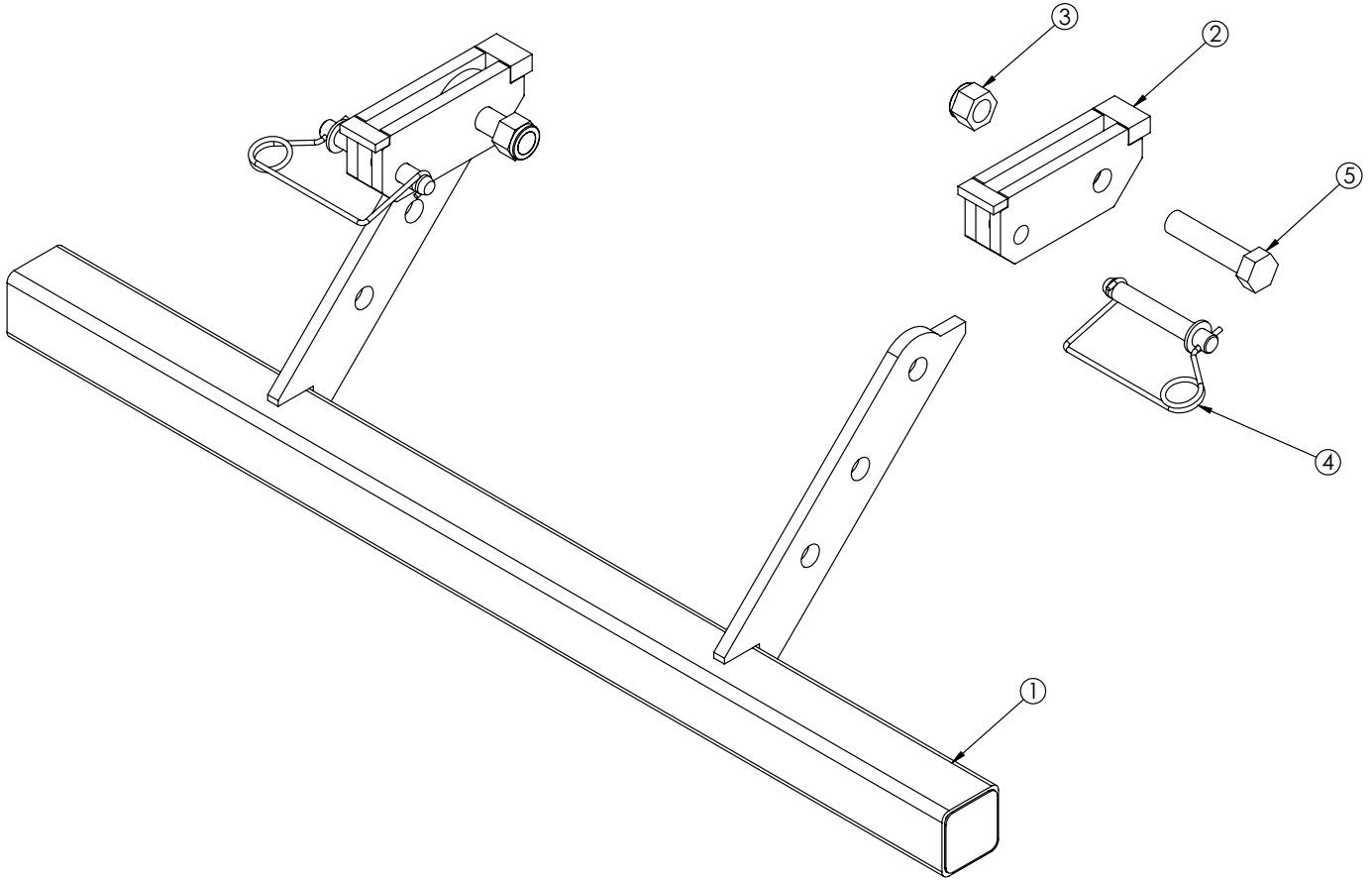

PN 46809

ITEM	PART	DESCRIPTION	QTY.
1	46804	BUMPER WLDMT ICC HEAVY DUTY KPAC	1
2	46877PC	PIVOT BLOCK WLDMT ICC KP60	2
3	5223	NUT 1.25-7 HHGR5 NYLOC	2
4	46810	PIN SNAP LOCK 1.00 KPAC 60-406	2
5	46811	CAP SCR 1.25-7X5.50 HHGR5	2

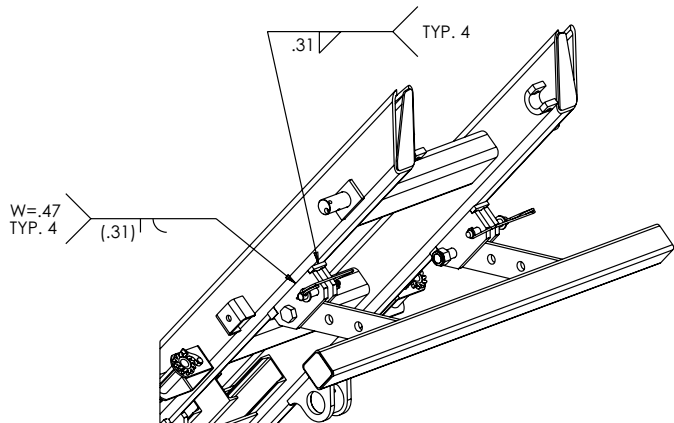
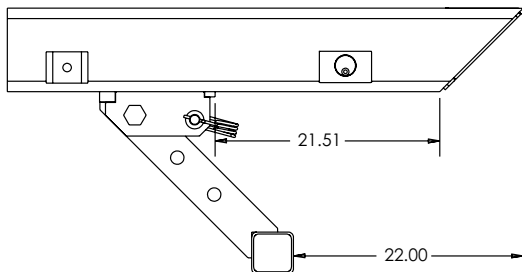

ICC Bumper Weldment - PN 45574

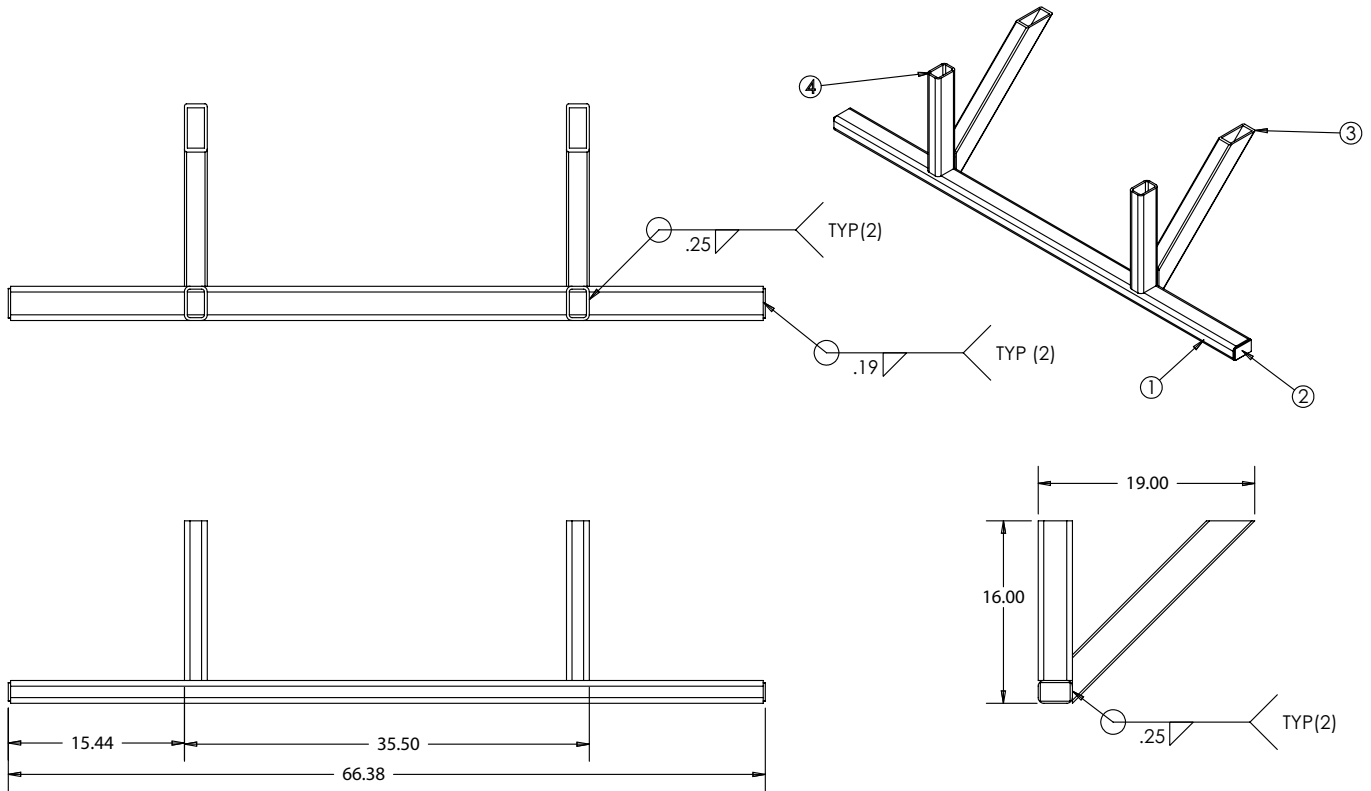

PN 45574

ITEM	PART	DESCRIPTION	QTY.
1	45572	TUBE 3.00X2.00X0.25WX66.00	1
2	43138	PLATE 0.19X2.63X1.63	2
3	45573	TUBE 3.00X2.00X0.25WX22.63	2
4	21447	TUBE 3.00X2.00X0.25WX14.00	2

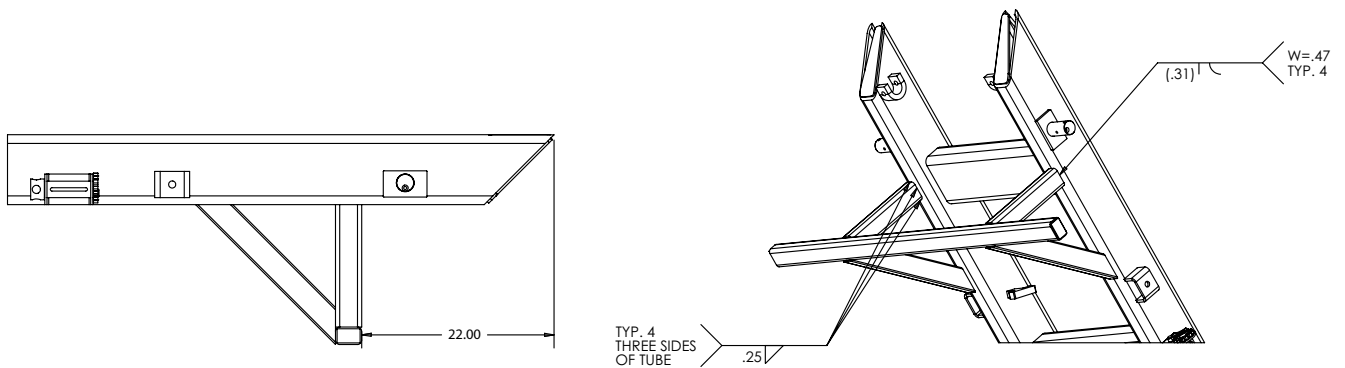

ICC Standard Narrow Bumper - PN 48848

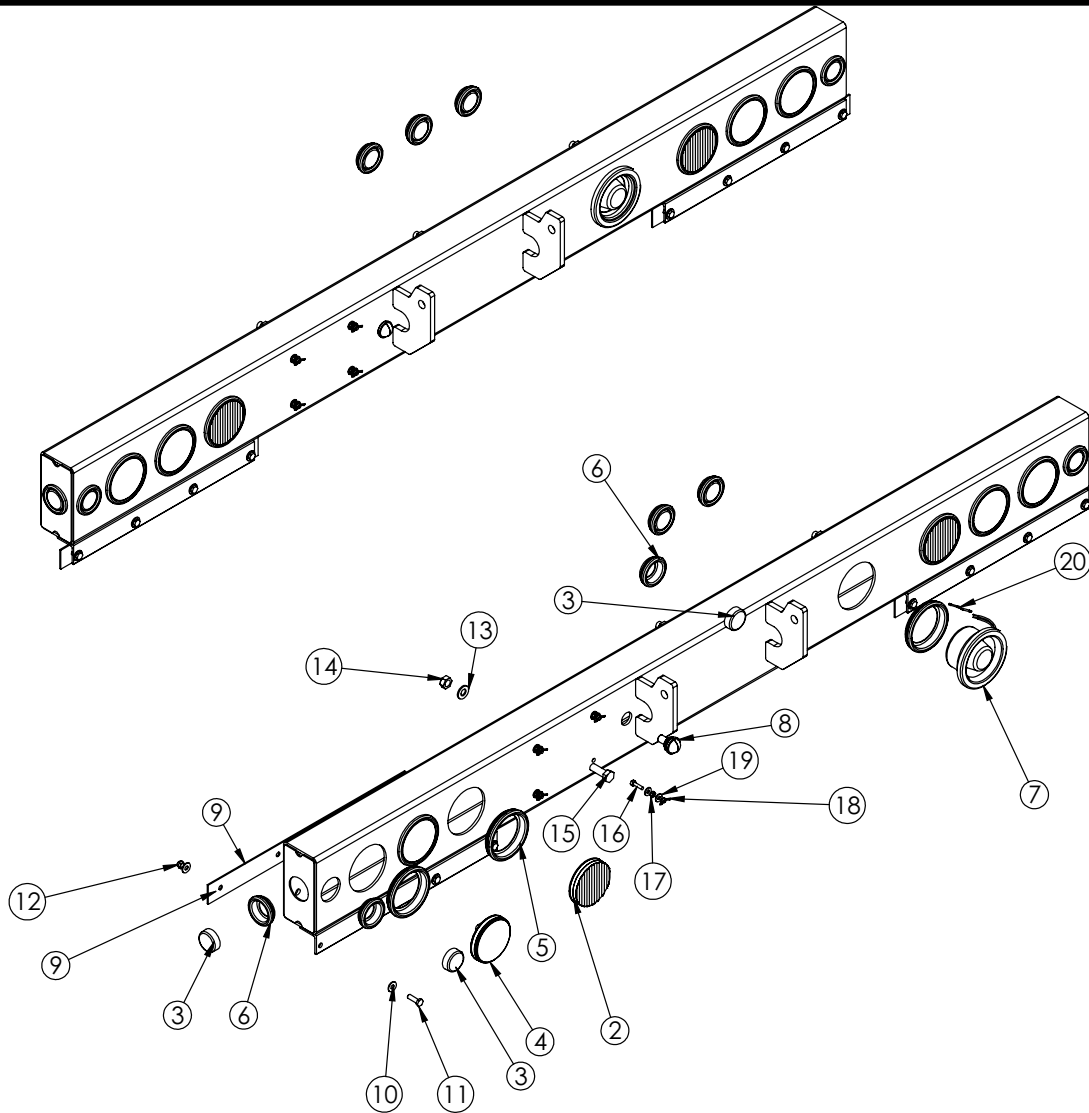

PN 48846

ITEM	PART	DESCRIPTION	QTY.
1	48849	BUMPER WLDMT STANDARD KP60 NRW ICC	1
2	27626	LIGHT BACKUP LED 62391	2
3	13145	LIGHT CLEARANCE RED RND 2 LED	7
4	13143	LIGHT STOP/TURN/TAIL 4 RND LED	4
5	10334	GROMMET 4.00 ROUND LAMP (PETERSON)	7
6	C4862	GROMMET FOR 2 CLEARANCE 30700	7
7	18742	BACKUP ALARM ACORN 97 DECIBAL	1
8	2320	LICENSE PLATE LIGHT ROUND 430 W	1
9	45039PC	PLATE MUD FLAP BACKING 43'FENDER KP	2
10	0346	WASHER 0.38 FLAT	16
11	0335	CAP SCR 0.38-16X1.25 HHGR5	8
12	0347	NUT 0.38-16 HH NYLOC	8
13	C5902	WASHER 0.63 SAE FLAT YELLOW GR8	12
14	24868	NUT 0.63-11 HHGR8 NYLOCK ZY	6
15	11693	CAP SCR 0.63-11X1.75 HHGR8	6
16	0480	CAP SCR 0.25-20X1.00 HHGR5	4
17	0533	NUT 0.25-20 HH	4
18	0654	NUT 0.25-20 WING	4
19	0340	WASHER 0.25 FLAT	8
20	C0073	TERML 16-14 BLUE BUTT WATER TIGHT	2

ICC Narrow Bumper - PN 48846

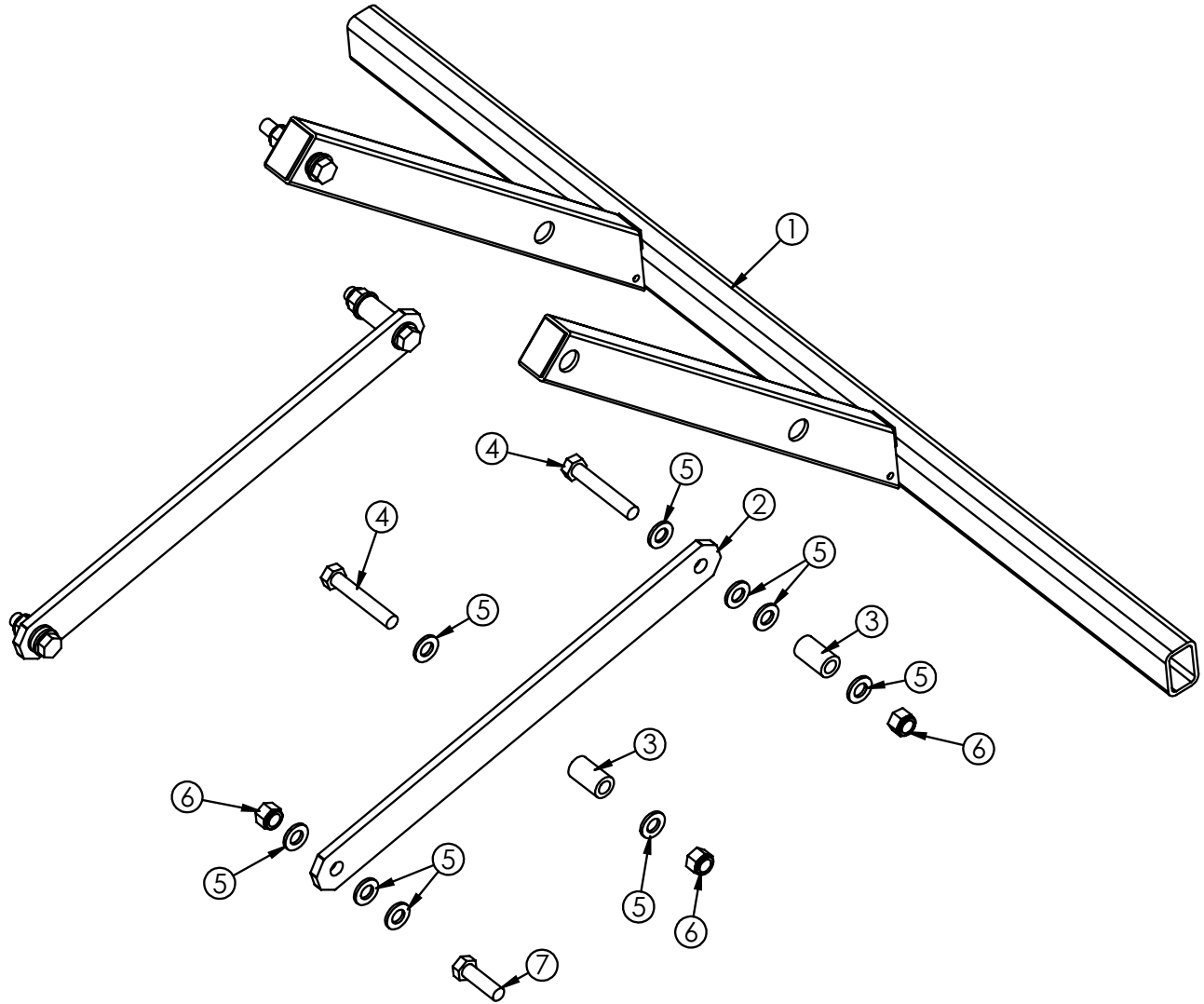

PN 48846

ITEM	PART	DESCRIPTION	QTY.
1	48847	BUMPER WLDMT ICC NARROW KPAC	1
2	45813	PLATE LINK ICC BUMPER	2
3	45815	SPACER 1.25ODX0.75IDX2.16	4
4	5841	CAP SCR 0.75-10X4.50 HHGR8	4
5	C6219	WASHER 0.75 SAE FLAT YELLOW GR8	18
6	C0538	NUT 0.75-10 HHGR8 NYLOC	6
7	58681	CAP SCR 0.75-10X2.50 HHGR8	2

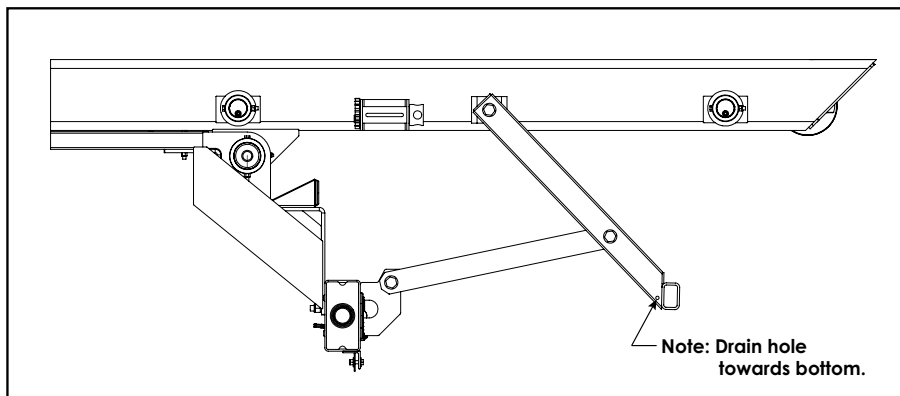

ICC Extendable Bumper - PN 62663

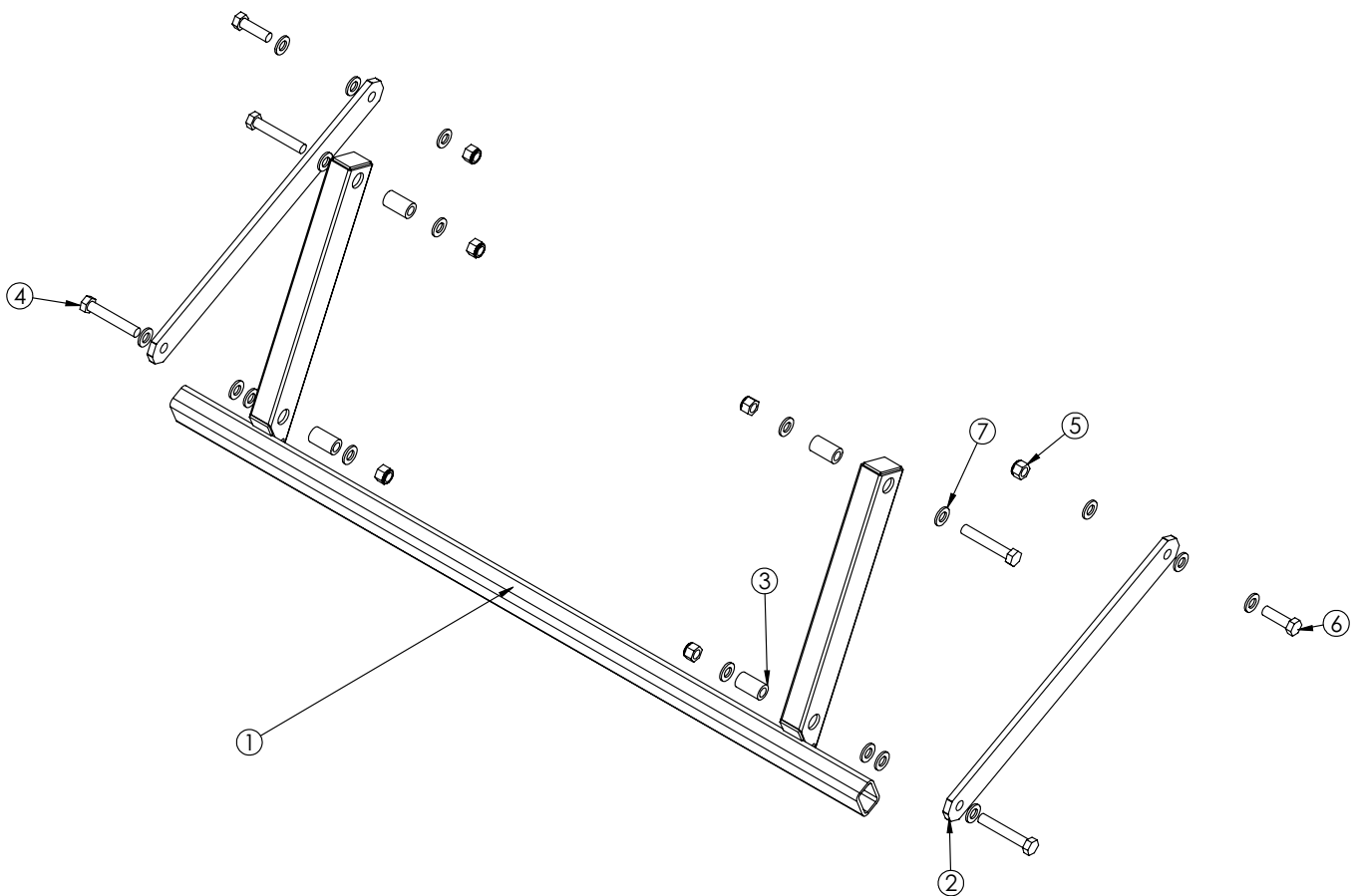

PN 62663

ITEM	PART	DESCRIPTION	QTY.
1	62664PC	BUMPER WLDMT ICC STANDARD EXT	1
2	45813PC	PLATE LINK ICC BUMPER	2
3	45815	SPACER 1.25ODX0.75IDX2.16	4
4	45623	CAP SCR 0.75-10X4.50 HHGR5	4
5	C0538	NUT 0.75-10 HHGR8 NYLOC	6
6	58681	CAP SCR 0.75-10X2.50 HHGR8	2
7	C6219	WASHER 0.75 SAE FLAT YELLOW GR8	18

Tri-Axle Fenders - PN 46299

NOTE: Includes PN 46122 Tandem Fenders

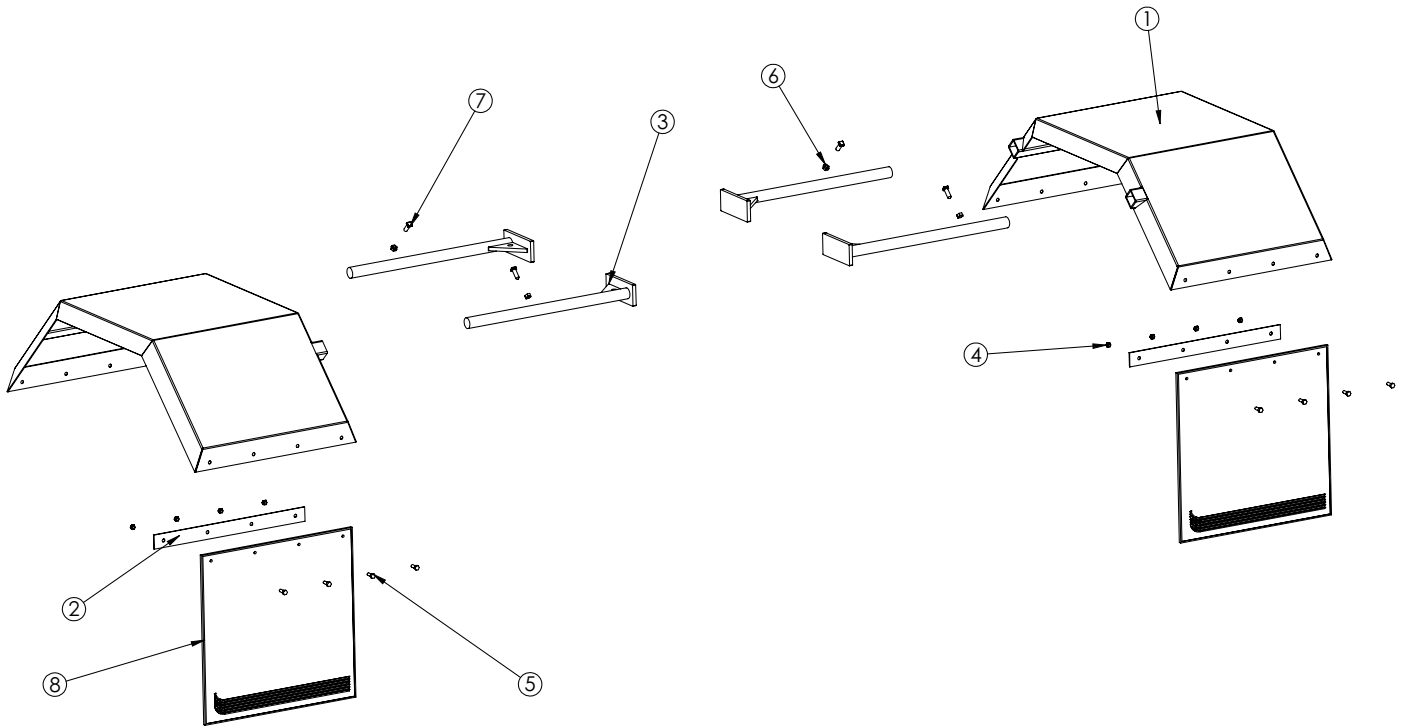

PN 46299

ITEM	PART	DESCRIPTION	QTY.
1	46626	STD FEND WELDMENT-48"	2
2	45039PC	PLATE MUD FLAP BACKING 43"FENDER KP	2
3	46627PC	FENDER SUPPORT WELDMENT	4
4	0347	NUT 0.38-16 HH NYLOC	8
5	0351	CAP SCR 0.38-16X1.00 HHGR5	8
6	0537	NUT 0.50-13 HH	4
7	46590	CAP SCR 0.50X1.50 SQ HD CP SS	4
8	C4821	MUD FLAP 24.00X24.00 STELLAR	2

NOTE: MUD FLAPS ARE ONLY INCLUDED WITH A FACTORY INSTALLATION

Tandem Fenders - PN 46122

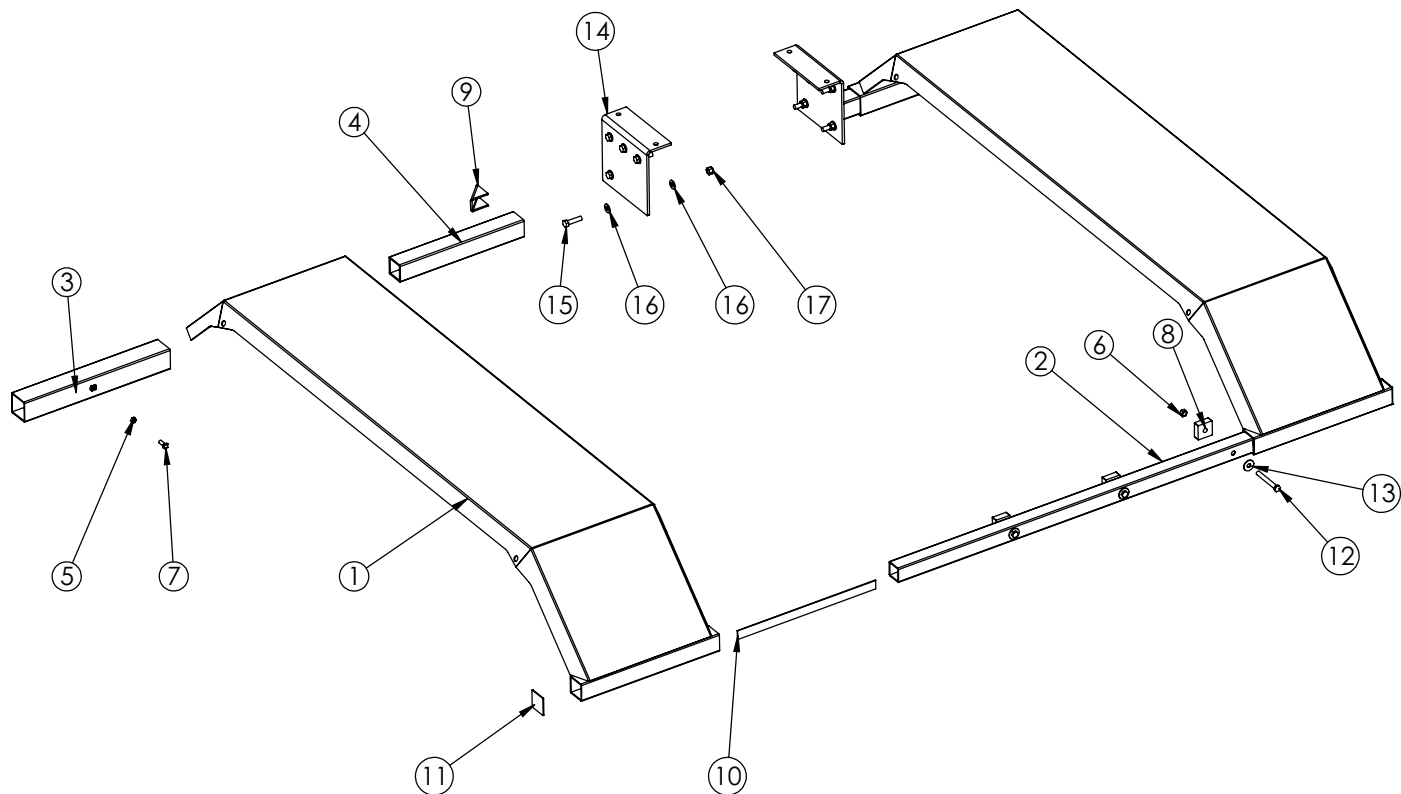

PN 46122

ITEM	PART	DESCRIPTION	QTY.
1	46121	WLDMT FENDER STEEL TANDEM KP60	2
2	46120PC	TUBE REAR FENDER SUPPORT	1
3	46119PC	WLDMT TUBE FRONT FENDER	2
4	46117PC	TUBE FRONT FENDER SUPPORT	2
5	0537	NUT 0.50-13 HH	4
6	2826	NUT 0.63-11 HH NYLOC	3
7	46590	CAP SCR 0.50X1.50 SQ HD CP SS	4
8	47208PC	PLATE 1.00X2.50X2.50 SPACER KP60	3
9	47209	BRKT FENDER KP60	2
10	47210	FLAT 0.13X1.50X24.50 HR	2
11	47211	CAP 0.13X3.00X2.88 FENDER KP60	2
12	C0966	CAP SCR 0.63-11X5.00 HHGR5	3
13	C1038	WASHER 0.63 FLAT	3
14	46906PC	BRKT GANTRY MNT KPAC	2
15	C1026	CAP SCR 0.63-11X2.50 HHGR8	10
16	C5902	WASHER 0.63 SAE FLAT YELLOW GR8	20
17	24868	NUT 0.63-11 HHGR8 NYLOC	10

Tandem Fenders - PN 46122 Continued...

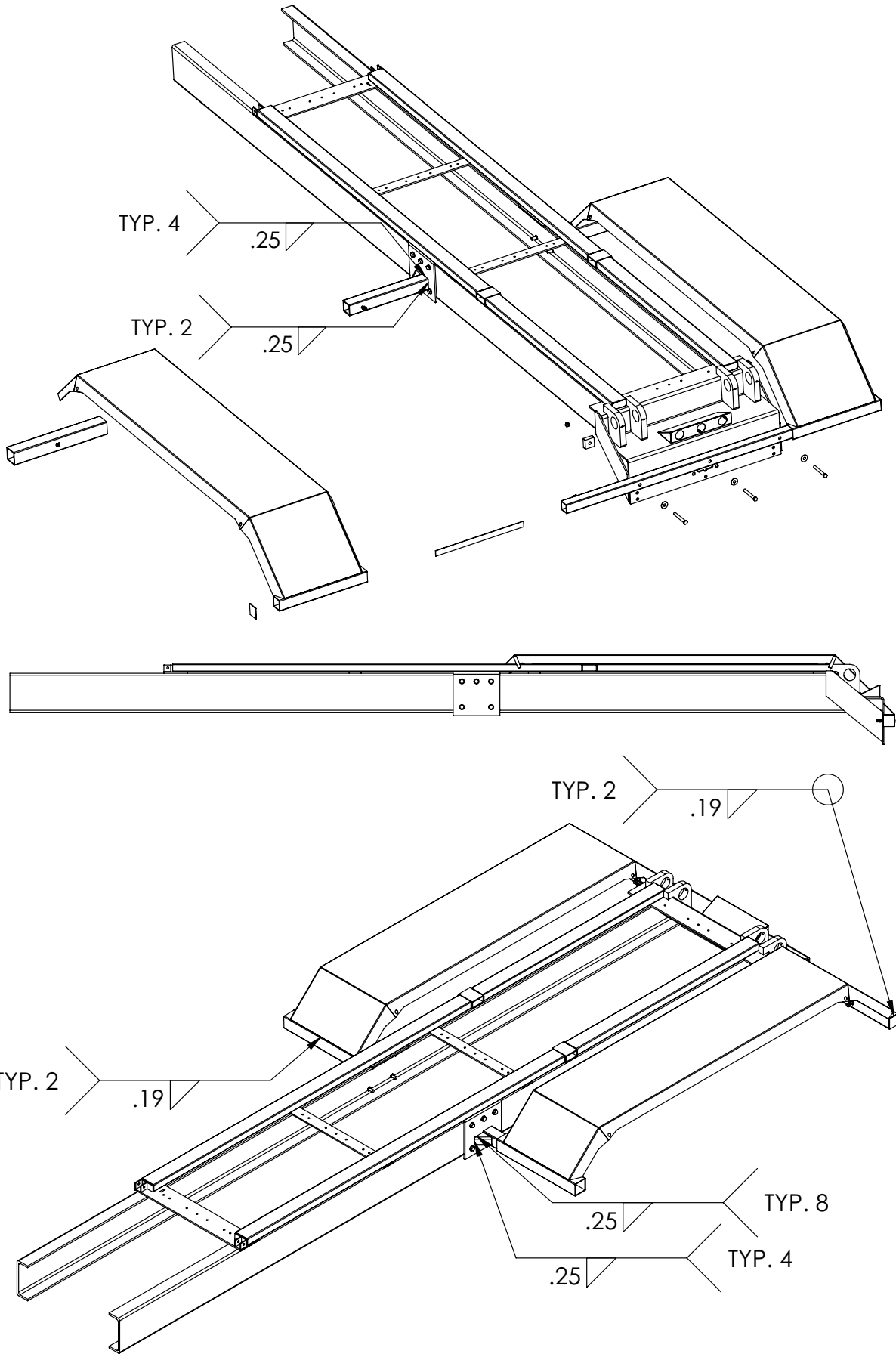

Tandem Poly Fenders - PN 45795

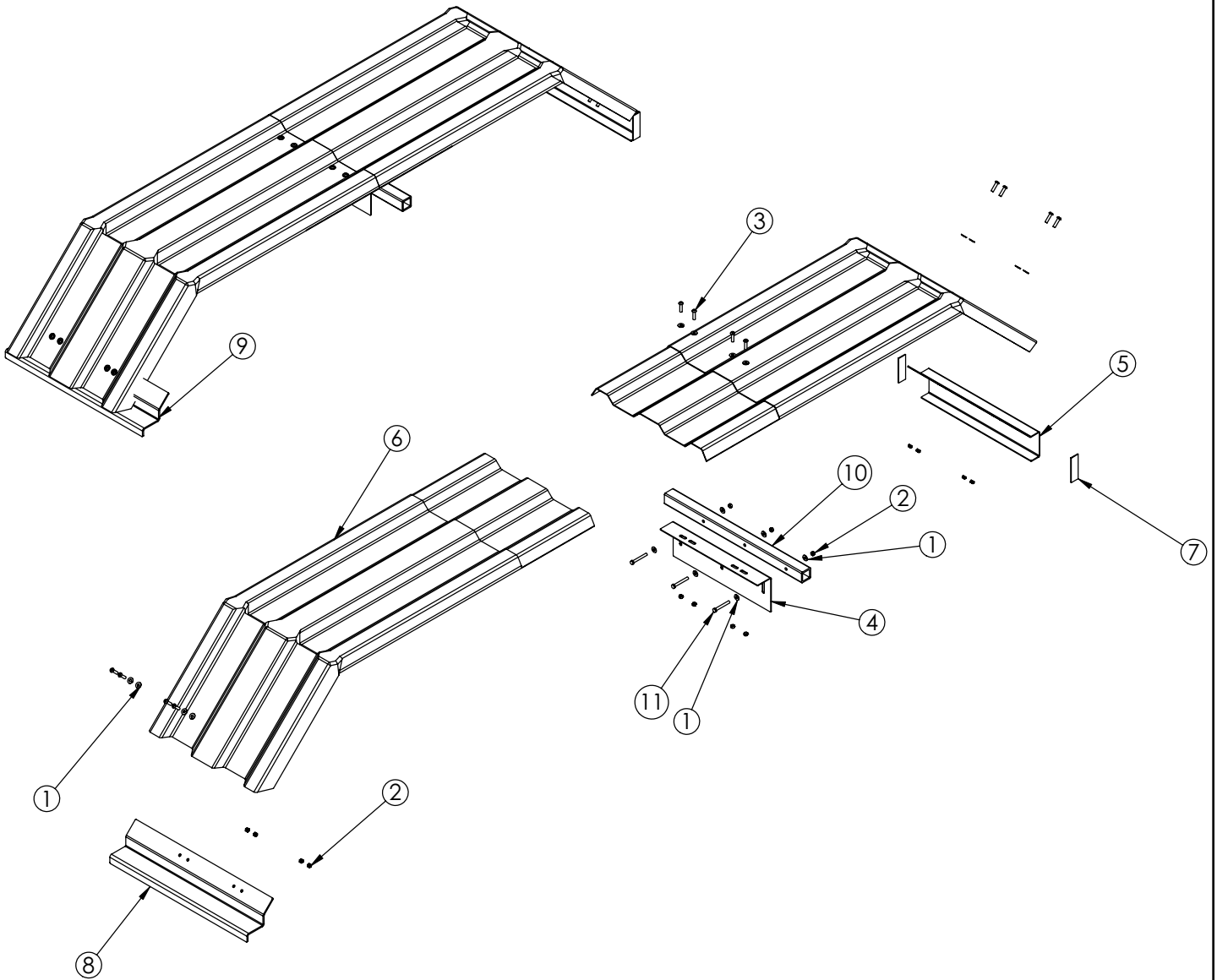

ITEM	PART	DESCRIPTION	QTY.
1	0346	WASHER 0.38 FLAT	36
2	0347	NUT 0.38-16 HH NYLOC	30
3	10682	CAP SCR 0.38-16X1.50 BTNHD SOCKT SS	24
4	45565PC	BRKT FENDER MNT CNTR KPAC TAND POLY	2
5	45566PC	BRKT FENDER MNT REAR KPAC TAND POLY	2
6	45567	FENDER TANDEM HALF KPAC POLY	4
7	45568	FLAT 0.13X1.50X4.63	4
8	45569PC	BRKT FENDER MNT FRRH KPAC TAND POLY	1
9	45570PC	BRKT FENDER MNT FRLH KPAC TAND POLY	1
10	45571PC	TUBE 2.00X2.00X0.25WX29.88	2
11	C0949	CAP SCR 0.38-16X3.00 HHGR5	6

Tri-Axle Poly Fenders - PN 45893

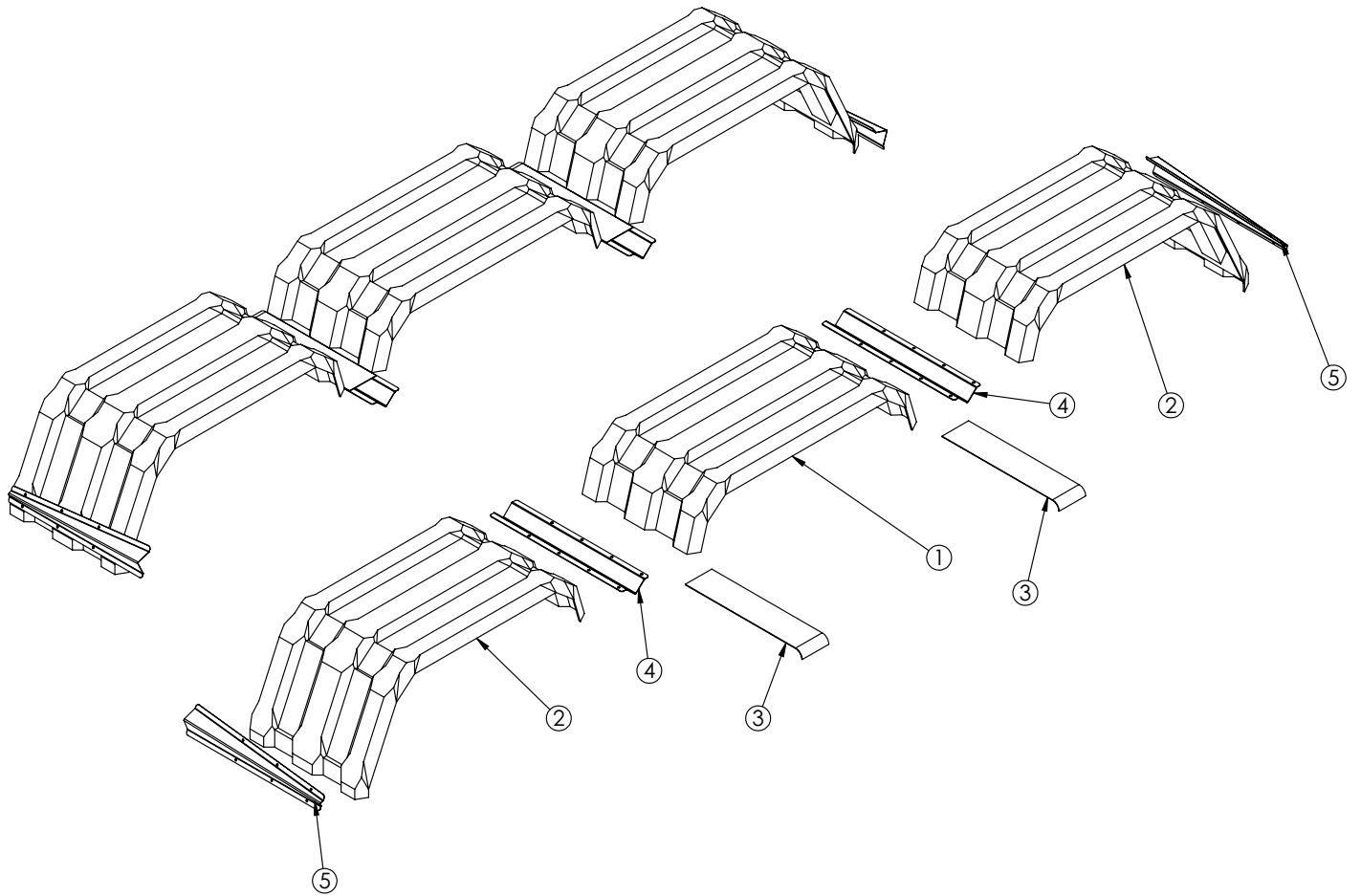

PN 45893

ITEM	PART	DESCRIPTION	QTY.
1	45891	FENDER TRI-AXLE MIDDLE POLY KPAC	1
2	45890	FENDER TRI-AXLE FRNT/REAR POLY KPAC	2
3	59596	FENDER TRI-AXLE TRIM PLATES POLY	4
4	45892	PLATE FORMED BRKT CNTR TRI POLY FENDER KPAC (QTY 4 INCLUDED IN KIT 45892)	4
5	45892	PLATE FORMED BRKT TAPERED POLY FENDER KPAC (QTY 4 INCLUDED IN KIT 45892)	4

Standard Lift Cylinder - PN 55262

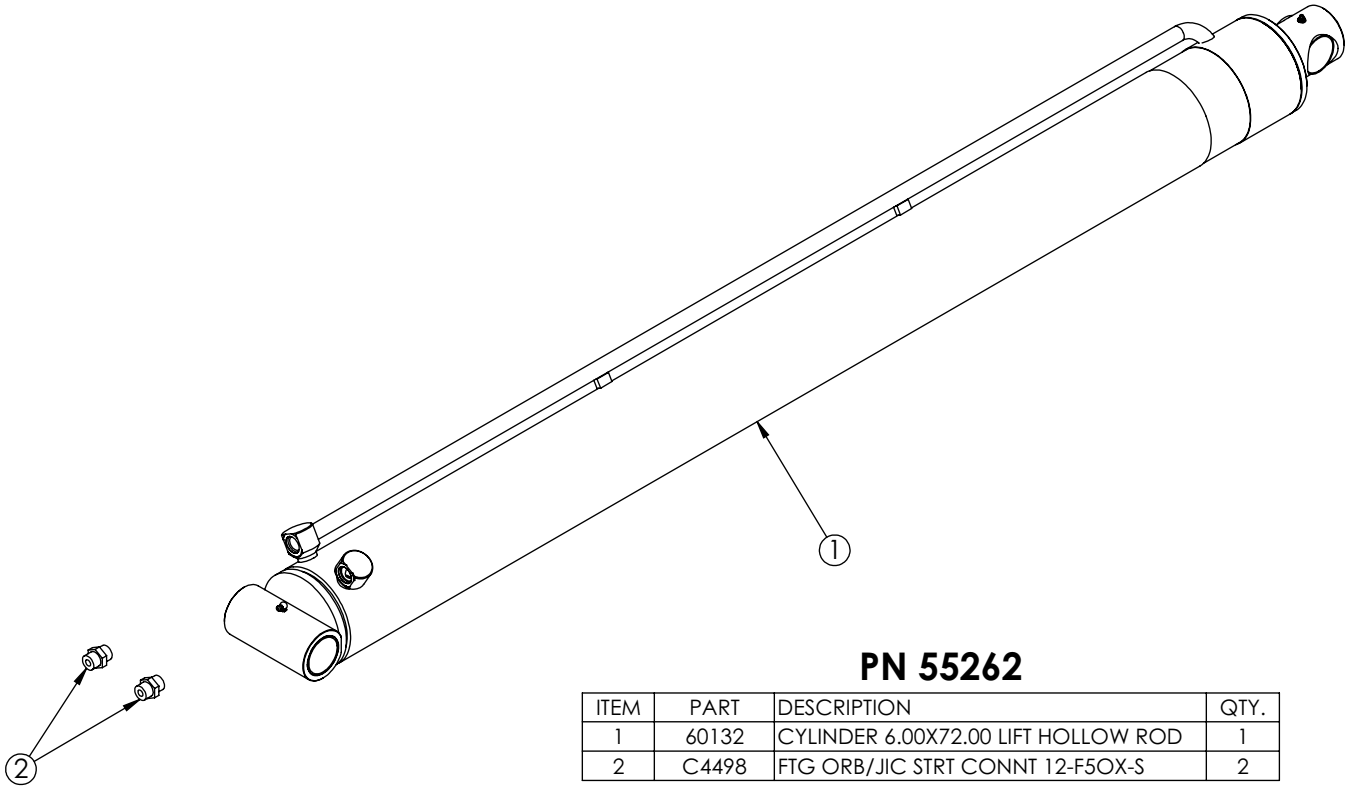

PN 55262

ITEM	PART	DESCRIPTION	QTY.
1	60132	CYLINDER 6.00X72.00 LIFT HOLLOW ROD	1
2	C4498	FTG ORB/JIC STRT CONNT 12-F5OX-S	2

Telescopic Lift Cylinder - PN 51078

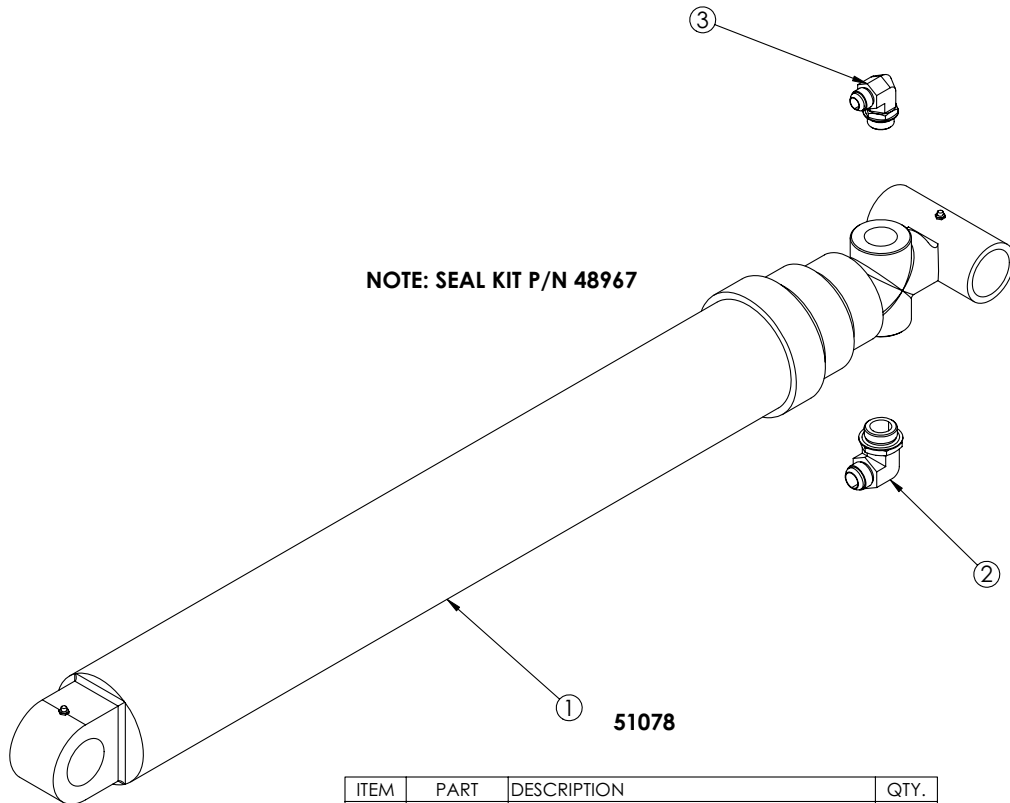

NOTE: SEAL KIT P/N 48967

51078

ITEM	PART	DESCRIPTION	QTY.
1	45737	CYLINDER 5.50X185.75 TELO KPAC	1
2	46113	FTG 90DEG MSTR/MJIC 16-20C50X	1
3	46114	FTG MJIC/MSTR 90 12-16 C50X	1

Standard Reeving Cylinder - PN 51080

174 and 182 Models

NOTE: SEAL KIT P/N 45306

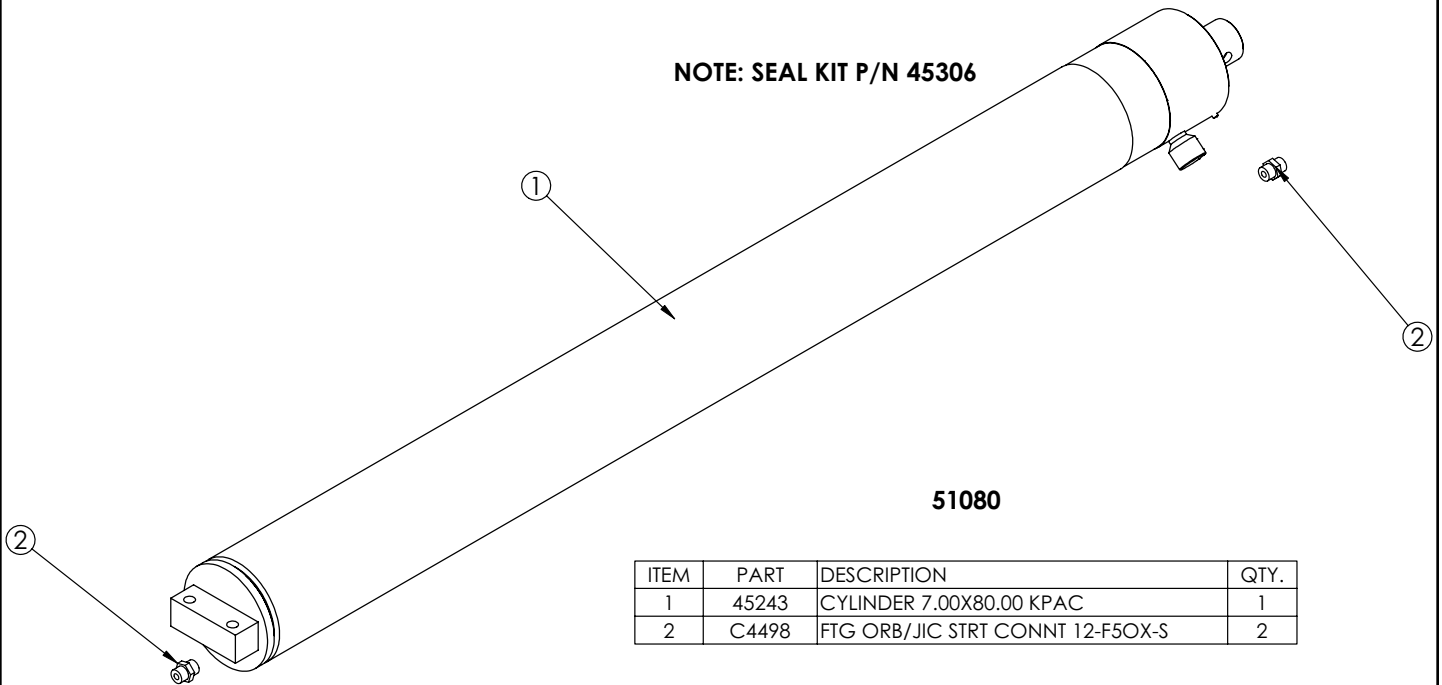

51080

ITEM	PART	DESCRIPTION	QTY.
1	45243	CYLINDER 7.00X80.00 KPAC	1
2	C4498	FTG ORB/JIC STRT CONNT 12-F5OX-S	2

Long Reeving Cylinder - PN 51201

194 Models

NOTE: SEAL KIT P/N 45306

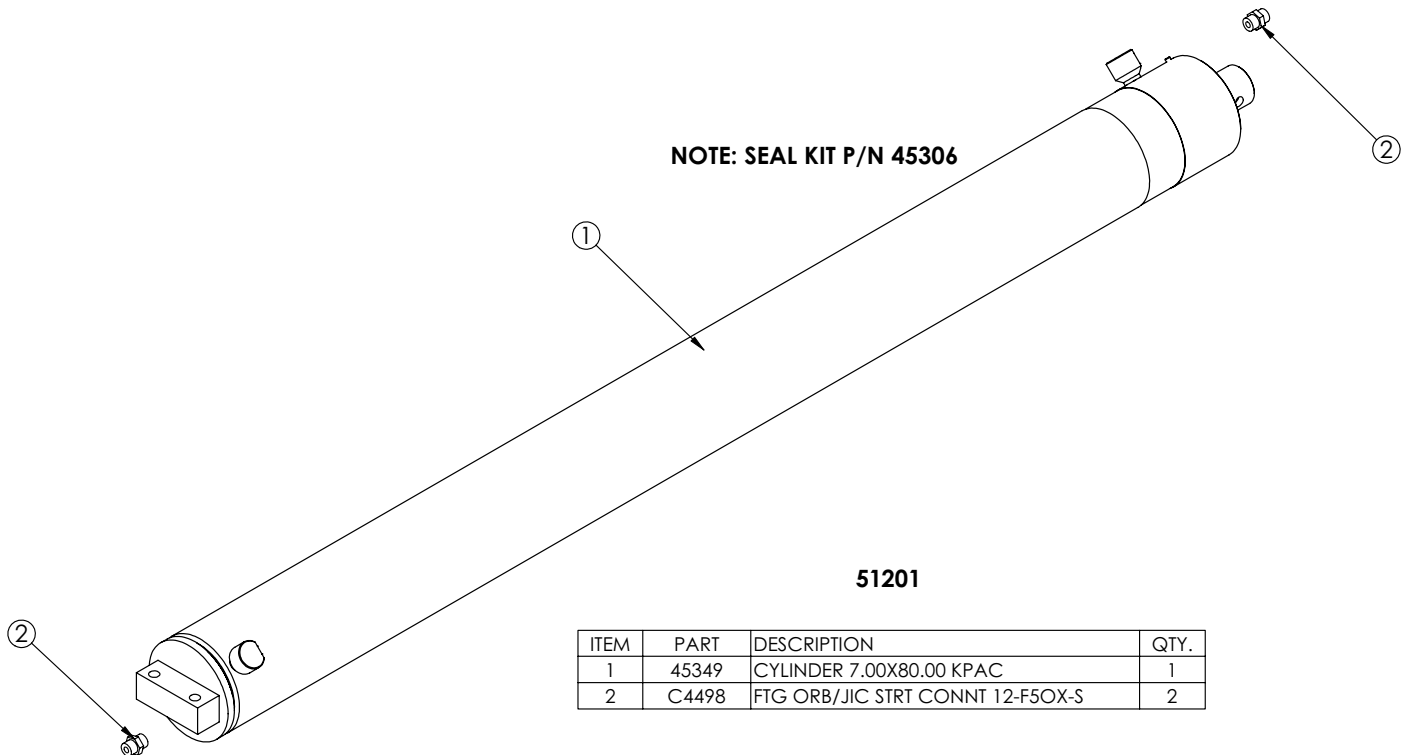

51201

ITEM	PART	DESCRIPTION	QTY.
1	45349	CYLINDER 7.00X80.00 KPAC	1
2	C4498	FTG ORB/JIC STRT CONNT 12-F5OX-S	2

Tail Extension Cylinder - PN 51202

IOX Models

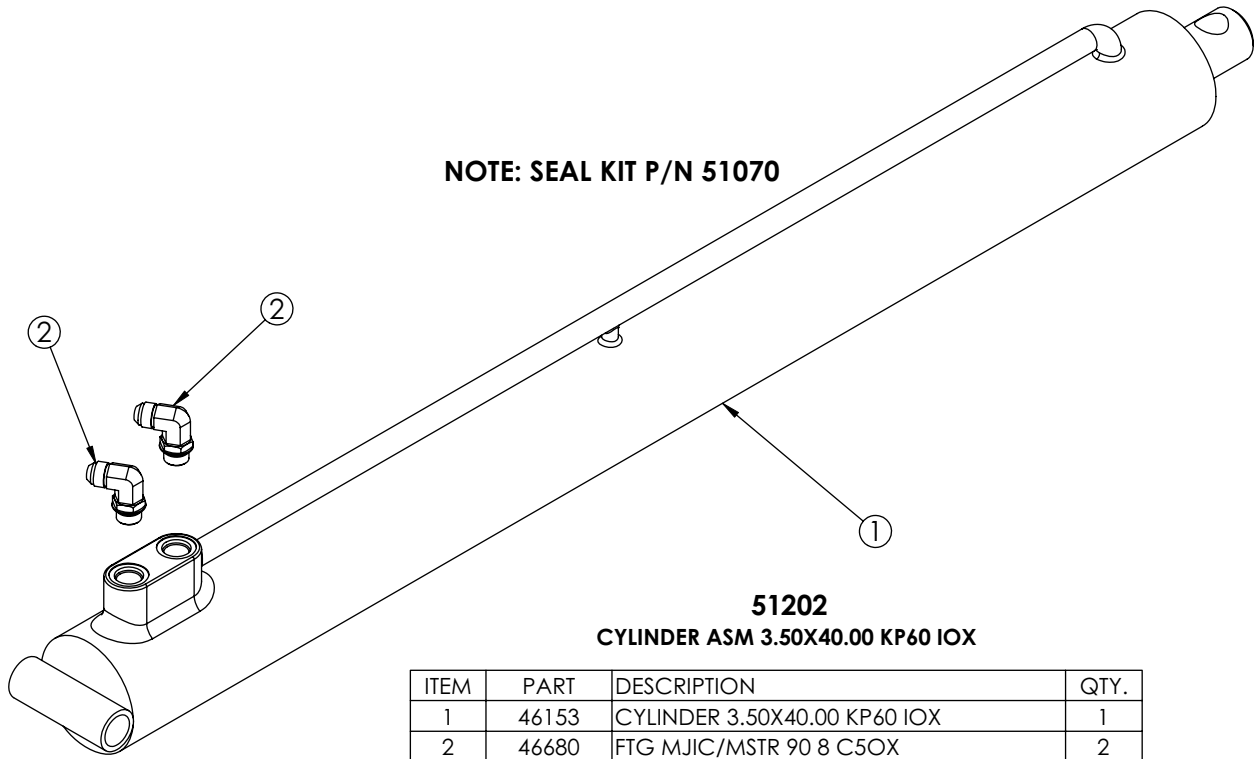

Tail Extension Cylinder - PN 51203

ORX Models

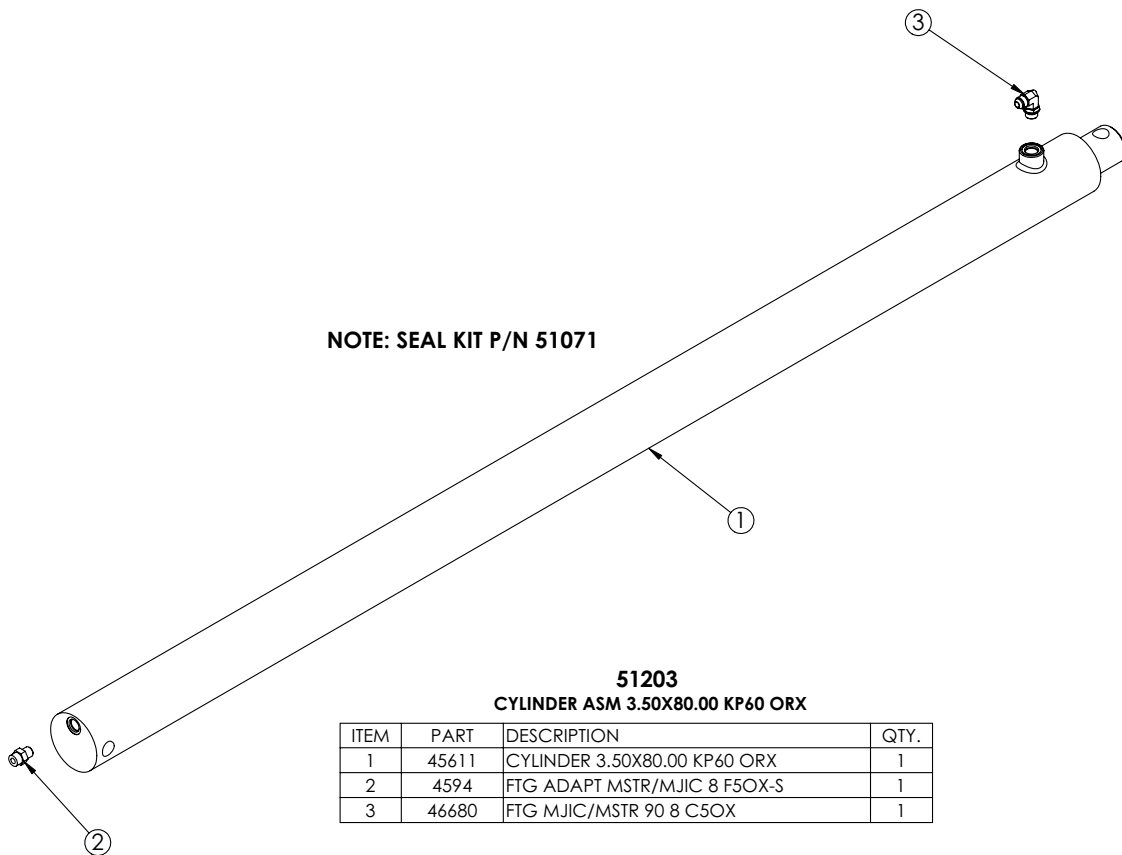

Ratchet Strap Kit - PN 45896

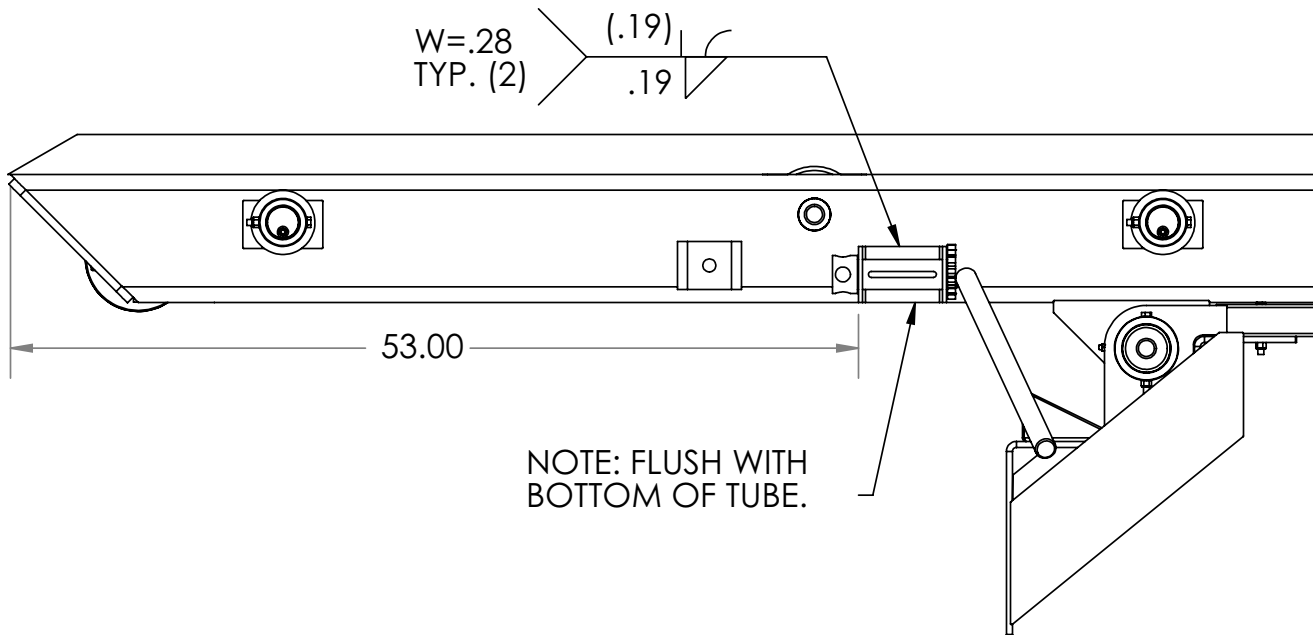
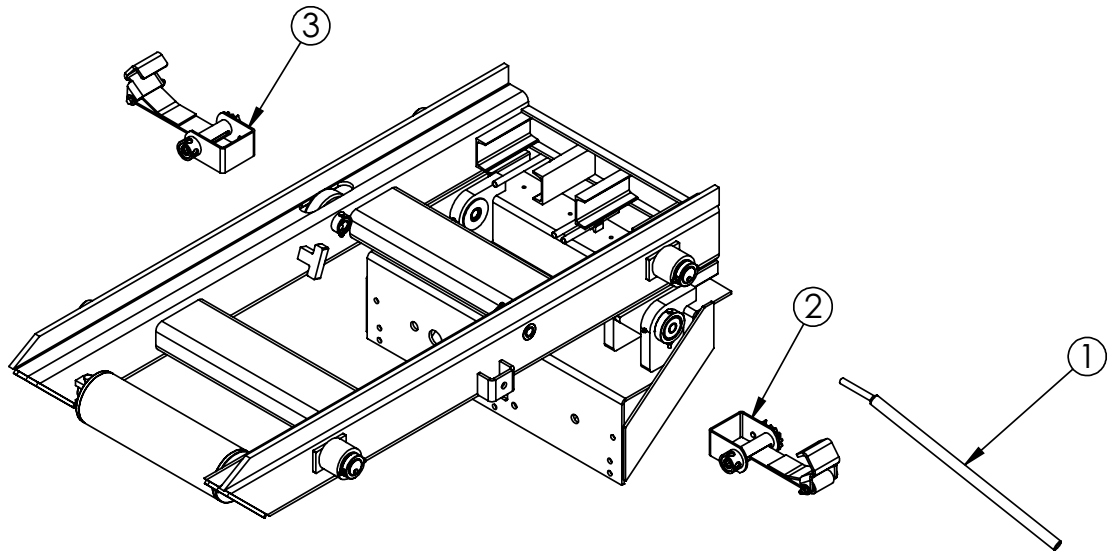

PN 45896

ITEM	PART	DESCRIPTION	QTY.
1	45895	WINCH BAR STANDARD	1
2	45326	HOLD DOWN KIT CS	1
3	60793	HOLD DOWN KIT SS	1

SS Hold Down Kit - PN 60793

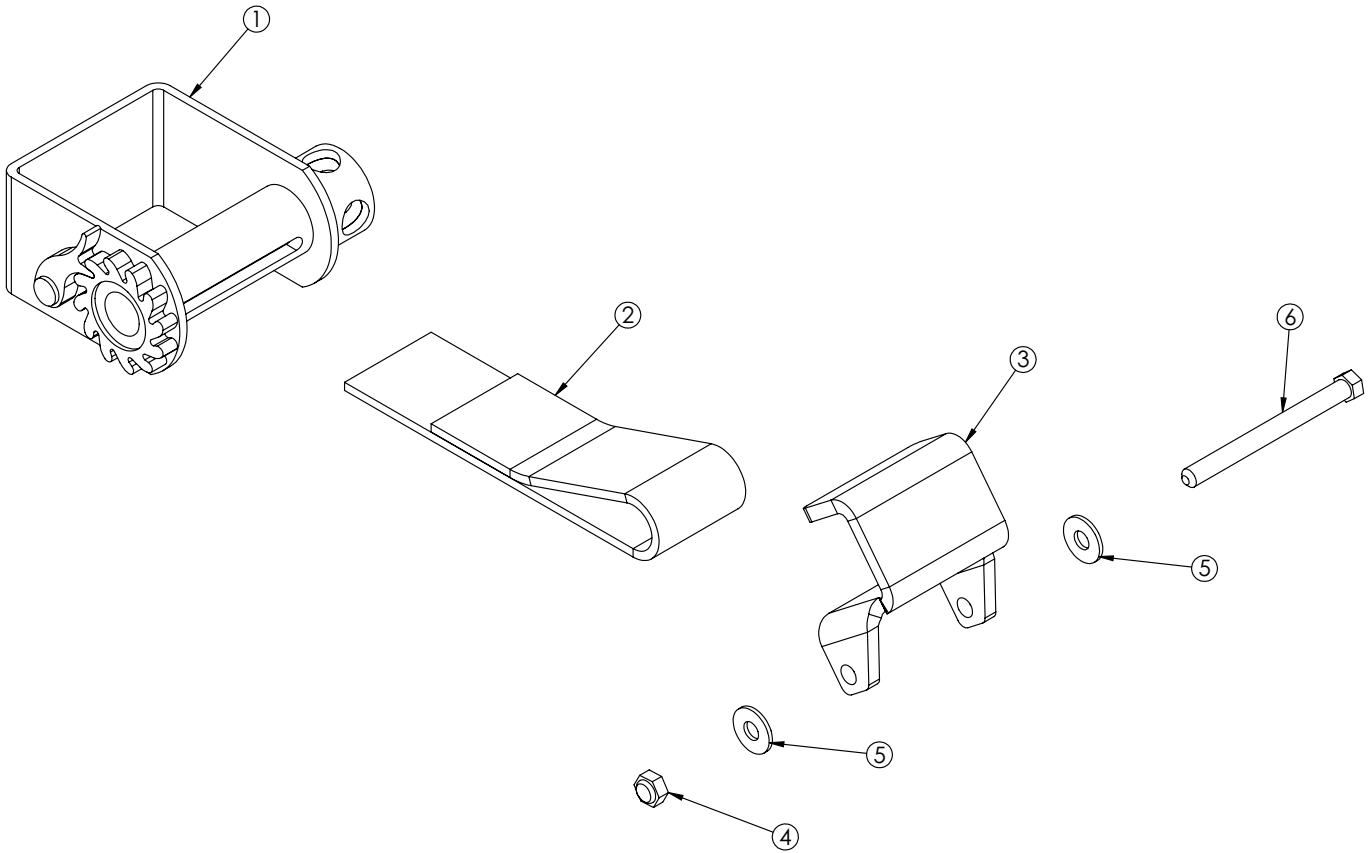

PN 60793

ITEM	PART	DESCRIPTION	QTY.
1	45495	WINCH TIE DOWN SS	1
2	45496	STRAP 3X36 W/LOOP KPAC	1
3	45497PC	STRAP HOOK (HOLD-DOWN) KPAC	1
4	C6106	NUT 0.50-13 HHGR5 NYLOC	1
5	0352	WASHER 0.50 USS FLAT ZINC	2
6	C1001	CAP SCR 0.50-13X5.50 HHGR5	1

CS Hold Down Kit - PN 45326

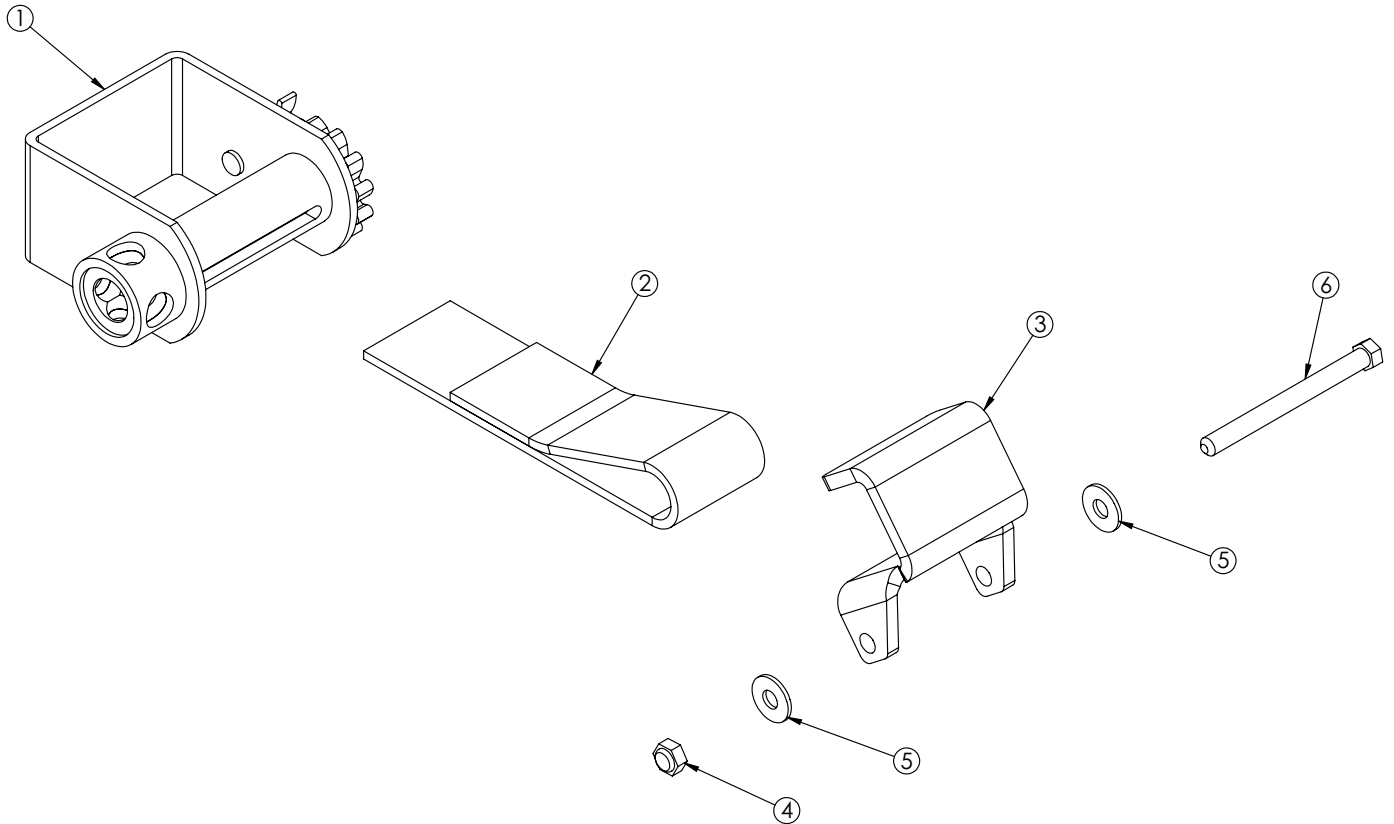

PN 45326

ITEM	PART	DESCRIPTION	QTY.
1	60805	WINCH TIE DOWN CS	1
2	45496	STRAP 3X36 W/LOOP KPAC	1
3	45497PC	STRAP HOOK (HOLD-DOWN) KPAC	1
4	C6106	NUT 0.50-13 HHGR5 NYLOC	1
5	0352	WASHER 0.50 USS FLAT ZINC	2
6	C1001	CAP SCR 0.50-13X5.50 HHGR5	1

Bolted Hold Down (Optional) - PN 42918

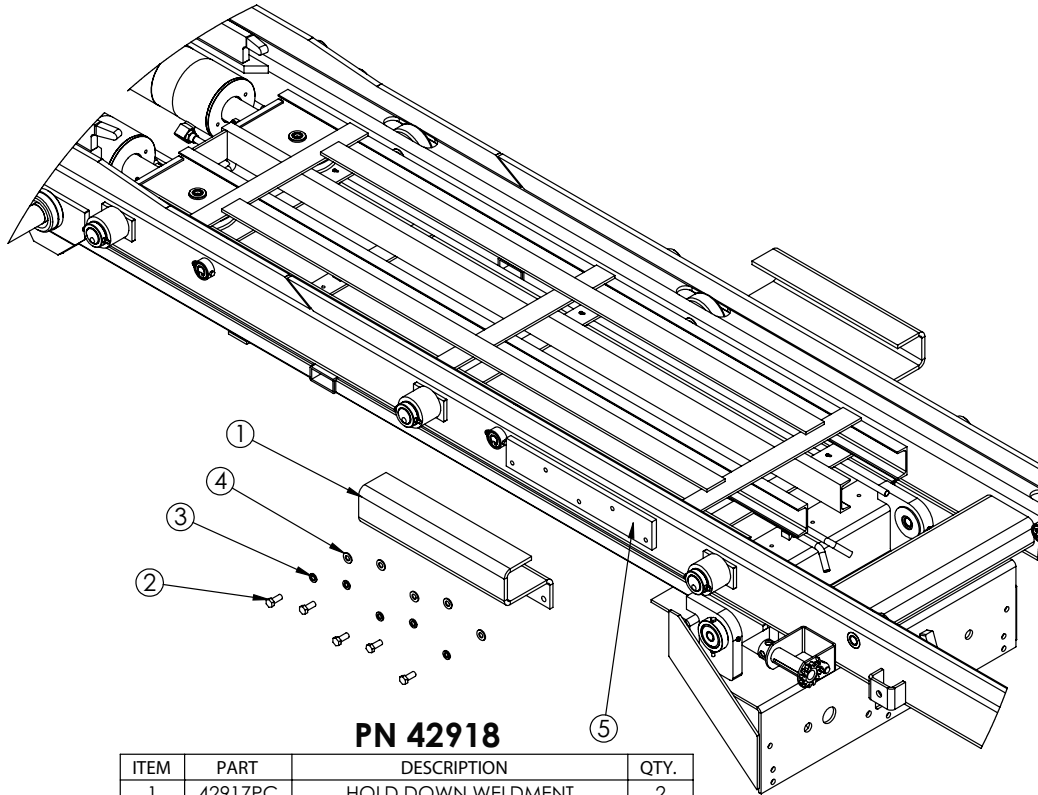

PN 42918

ITEM	PART	DESCRIPTION	QTY.
1	42917PC	HOLD DOWN WELDMENT	2
2	0356	CAP SCR 0.63-11X1.50 HHGR8	10
3	0526	WASHER 0.63 LOCK	10
4	C5902	WASHER 0.63 SAE FLAT YELLOW GR8	10
5	45859	FLAT TAP HOLD DOWN KP60	2

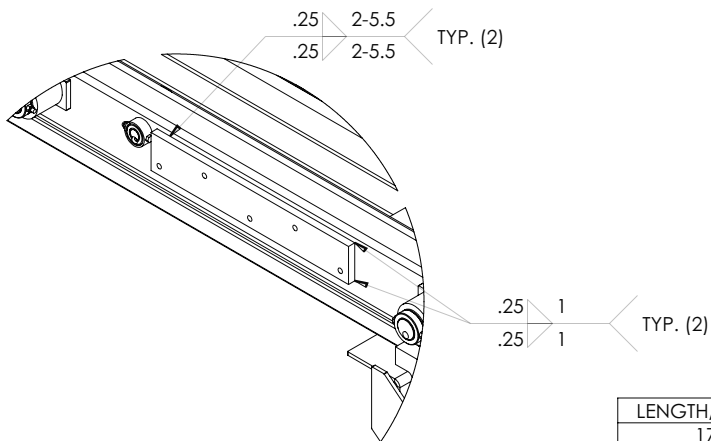

LENGTH/MODEL	DIM. A	DIM. B
174	35.75"	
182/194	43.75"	
IO		5.50"
OR		8.00"

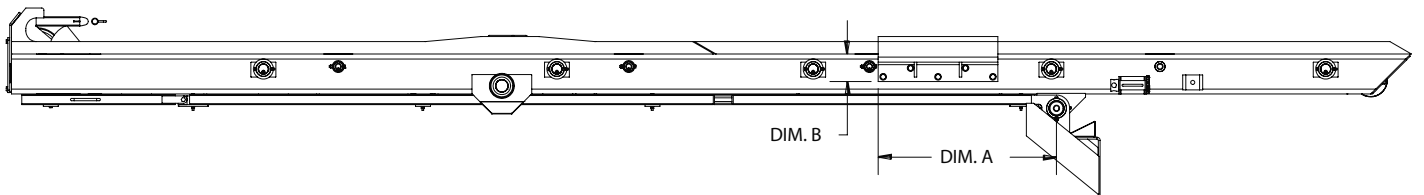

Chapter 8 - Replacement Parts

Hydraulic Components

Part number	Description
15463	Thermo Sight gauge
45074	Breather cap - Fill neck
15464	Tank cover - Clean out
C6327	Filter strainer
45332	Filter element
45503	Relief valve
45343	Cylinder 6.00" x 72.00" Lift
45749	Cylinder seal kit (45343) 6.00 x 72.00
45737	Cylinder - Telescopic 5.50" x 185.75" Lift
48967	Cylinder seal kit (45737) 5.50" x 185.75"
45243	Cylinder - Standard Reeving model 174 & 182 SI60 7.00" X 80.00"
45306	Cylinder seal kit (45243 & 45349) 7.00" x 80.00" 174, 182, & 194
45349	Cylinder - Long Reeving model 194 SI60 7.00" X 80.00" Long
46153	Cylinder - Tail Extension SI60 IOX model hoists 3.50" x 40.00"
51070	Cylinder seal kit (46153) 3.50" x 40.00"
45611	Cylinder - Tail Extension SI60 ORX model hoists 3.50" x 80.00"
51071	Cylinder seal kit (45611) 3.50" x 80.00"

Cable Hoist Components

Part number	Description
45372PC	Collar retaining 2.75x2.03x0.75
0427	Machine Washer 2.00ID 10ga.
1589	Machine Washer 3.00ID 14ga.
C1592	Grease Zerk 1/8 NPT straight
45373	Roller 4.00" outside SI60
45564	Roller - Rear Assembly SI60
45304	Roller 6.00" SI60 Inside
45481	Shaft - Vertical sheave
45523	U-Bolt Clamp 0.88" SI60
46905	U-Bolt Clamp 1.00" SI75
45556	Cable asm - Reeving cylinders 0.88" x 71 ft
45500	Cable asm - Reeving cylinders 0.88" x 81 ft
45410	Cable end casting SI60
45411	Cable end - 0.88"
46604	Cable end - 1.00"
42393	Spring
45114	Reeving Sheave weldment SI60
46712	Reeving Sheave weldment SI75
45138	Pin sheave and cable shaft
45139	Sheave 10" - cable asm SI60
45583	Strap weldment cylinder reeving SI60
49565	U-Bolt 0.50" x 6.75"w x 7.88"
47277	Removable stop - OR model Cable hoists
47276	Removable stop - OR model Cable hoists
47272	Intermediate stop - IO Fold down stop
45621	Intermediate stop - OR Fold down stop

Chassis Mounted Components

Part number	Description
45600	Mount Brkt - Truck frame lug SI60
47531	Pin - Pivot
45144	Pin - 2.50" drop shaft SI60
45756PC	Collar 2.51x3.25x1.50 w/hole

Controller & Electrical Components

Part number	Description
46734	Controller - Straight No Lock
42399	Controller - Joystick
47471	Controller - Pneumatic
49580	Controller - 2 section Pneumatic
45159	Air Actuator (V42)
45798	Handle kit - 2 section VB
D1810	Air Line for air controllers
45907	Switch - Remote SI60
45908	Light - Dump up
46658	Control Cable 108"
46713	Control Cable 156"
47284	Control Cable 252"
46291	Cable connection kit (V20)

Rear Bumper Components

Part number	Description
13143	Light - Stop/Turn/Tail 4" Round LED
27626	Light - Back up LED
13145	Light - Clearance (Red) 2" Round LED
13144	Light - Clearance (Amber) 2" Round LED
2320	Light - License plate
18742	Back up Alarm
45813PC	Flat link - ICC Bumper
45815PC	Spacer 1.25"OD x 0.75"ID x 2.16"
46810	Pin snap lock - 1.00" ICC Heavy duty bumper

Under Body Tool Box Components

Part number	Description
23759	Latch - Door
23764	Latch Gasket - Door
33914	Door roller asm for 1 side Includes 4110, 22045, 4166, 4659
4410	Roller OH door
22045	Bracket - Roller OH door
4166	Cap Screw - Shoulder 0.38"
4659	Nut - Center lock 0.38"
4183	Angle - UHMW RH
4167	Angle - UHMW LH

Fender Components

Part number	Description
46626	Fender Weldment - Standard 48"
46121	Fender Weldment - Steel Tandem SI60
45567	Fender - Tandem Poly SI60 Half
45891	Fender - Tri-Axle Middle section Poly
45890	Fender - Tri-Axle Front & Rear sections Poly
C4821	Mud Flap 24.00" x 24.00" Stellar



Subject to Change without Notification.
© 2016 Stellar Industries, Inc.