



Expert Series

Flexibility, Because Every Route is Different

- 15 yd³ to 37yd³ body sizes
- Up to 850 lbs/yd³ compaction, 12 second packing cycle
- 50/50, 40/60 or 60/40 Split Body configurations available for dual collection
- Single piece body walls for increased strength and seamless appearance
- Manual, Semi-Automated and Fully Automated configurations available
- Dual Helping-Hand™ configuration available
- Labrie proprietary drop frame modification performed in house
- Tapered body for improved compaction and easy unloading
- Separate 3 yd³ or 5 yd³ glass compartments (as shown)
- Multiplex Electrical System with In-Cab Diagnostic tools for easy troubleshooting
- Fully Integrated Labrie CNG Systems - roof, tailgate and back of cab mount - 50 to 100 DGE available
- Helping Hand™ Arm with optional 10' reach
- Hopper enclosed arm dumps directly into packer area
- Fully enclosed hopper contains litter, minimizes debris from blowing out



Body Specifications

Body Floor	3/16" 50W 50,000 psi
Body Sides (lower)	10ga A1011 80,000psi
Body Roof	12ga A1011 80,000psi
Tailgate	12ga A1011 80,000psi

Hopper Specifications

Hopper Size (yd ³)	4
Loading Height	5-1/2" above frame
Hopper Floor	3/16" 50W 50,000 psi
Hopper Floor wear plates	1/4" AR500 190,000psi
Hopper Sides (lower)	3/16" AR200 70,000 psi
Hopper Sides wear plates	0.157" AR450 175,000psi
Hopper Slope	1/4" AR500 190,000psi
Hopper Slope wear plates	1/4" AR500 190,000psi

Packer Specifications

Compaction ratio (lbs/yd ³)	850 (600 on single axle chassis)
Packer Panel Face Plate	1/4" 100QT 100,000psi
Packer width	71"
Packer height	18"
Packer stroke	50"

Arm Specifications (automated units)

Arm Lift Capacity	400 lbs
Arm Reach	84" (120" optional)
Swing out	16"
Arm Controls	Proportional joystick, electric over hydraulic

Hydraulic Specifications

Pump	Single Vane (Manual) / Dual Vane (Automated)
Pump Capacity (Manual)	38 gpm@1200 rpm
Pump Capacity (Automated)	BODY: 20 gpm@700 rpm; ARM: 16 gpm@700 rpm
Max. Operating Pressure	3,000 psi (2,000 psi on single axle chassis)
Oil Reservoir (conventional cab)	65 gal

Cylinder Specifications

Body Lifting Cylinder (15-20 yd ³ bodies)	4 stages 6-1/16" bore x 150" stroke
Body Lifting Cylinder (22 yd ³ bodies)	4 stages 6-1/16" bore x 165" stroke
Body Lifting Cylinder (27-31 yd ³ bodies)	4 stages 6-1/16" bore x 180" stroke
Packer Cylinders	4" bore x 2-1/2" rod x 40" stroke
Crusher Panel Cylinder	2" bore x 1-1/2" rod x 14-1/2" stroke
Tailgate Cylinders	2-1/2" bore x 1-3/4" rod x 39" stroke
Arm extension Cylinder (84" reach)	2" bore x 1-1/4" rod x 70" stroke
Arm extension 2nd Cylinder (120" reach)	2" bore x 1-1/4" rod x 36" stroke
Lifting Cylinder	3" bore x 1-1/2" rod x 16" stroke
Grabber Cylinder	1-1/2" bore x 1" rod x 6-1/4" stroke

Note: Specifications subject to change without notice



Performance Specifications

Arm In (72" reach)	2.4 sec @ 700 rpm
Arm In (84" reach)	2.8 sec @ 700 rpm
Arm In (120" reach)	4.5 sec @ 700 rpm
Arm Out (72" reach)	3.2 sec @ 700 rpm
Arm Out (84" reach)	3.7 sec @ 700 rpm
Arm Out (120" reach)	6.0 sec @ 700 rpm
Arm Up	2.5 - 3.0 sec @ 700 rpm
Arm Down	2.5 - 3.0 sec @ 700 rpm
Grabber Open	1.3 - 1.8 sec @ 700 rpm
Grabber Close	1.0 - 1.5 sec @ 700 rpm

Packer complete cycle without regeneration	12 sec @ 1200 rpm
Packer complete cycle with regeneration	14 sec @ 700 rpm
Tailgate Open	21 sec @ 700 rpm
Tailgate Close (with Safety Flow limiter)	26 sec @ 700 rpm
Body Up (depending on body size)	30-40 sec @ 700 rpm
Body Down (depending on body size)	15-25 sec @ 700 rpm
Crusher panel Up	4 sec @ 700 rpm
Crusher panel Down	3 sec @ 700 rpm
Hydraulic chute to curb side	4 sec @ 700 rpm
Hydraulic chute to street side	4 sec @ 700 rpm

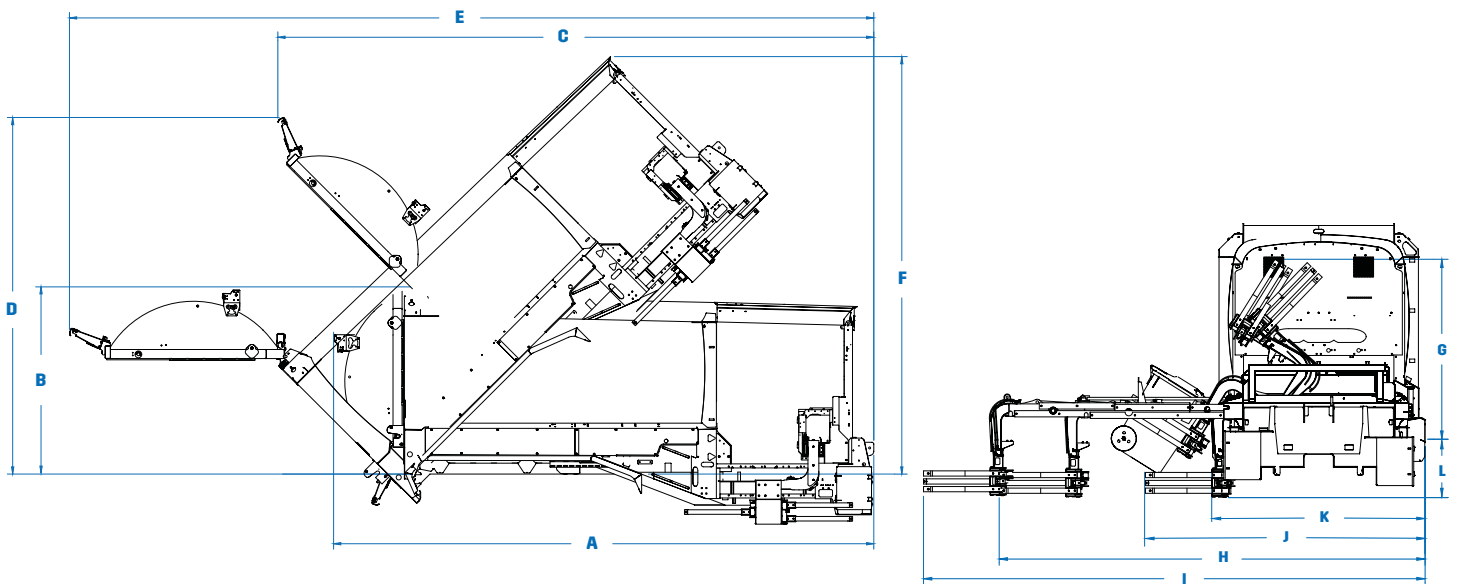

Body Dimensions

	15yd ³ (15+0)	17yd ³ (15+2)	20yd ³ (20+0)	22yd ³ (20+2)	24yd ³ (20+4)	24yd ³ (22+2)	26yd ³ (22+4)	27yd ³ (27+0)	29yd ³ (27+2)	31yd ³ (27+4)	33yd ³ (27+6)	31yd ³ (31+0)	33yd ³ (31+2)	35yd ³ (31+4)	37yd ³ (31+6)
A. Overall Length, Tailgate Closed (in.)	239	248	240	245	258	261	274	280	285	298	313	310	315	328	343
Overall Width (in.)	102	102	102	102	102	102	102	102	102	102	102	102	102	102	102
B. Overall Height Above Frame, Tailgate Closed (in.)	82	82	103	103	103	103	103	103	103	103	103	103	103	103	103
C. Overall Length, Tailgate Open (in.)	281	281	289	289	289	305	305	329	329	329	329	359	359	359	359
D. Overall Height Above Frame, Tailgate Open (in.)	165	165	197	197	197	197	197	197	197	197	197	197	197	197	197
E. Overall Length, Dumping Position (in.)	375	375	403	403	403	419	419	444	444	444	444	470	470	470	470
F. Overall Height Above Frame, Dumping Position (in.)	185	185	201	201	201	213	213	230	230	230	230	244	244	244	244
G. Overall Height Above Frame When Dumping (in.)	86	86	86	86	86	86	86	86	86	86	86	86	86	86	86
H. Overall Width, Arm Out (STD), Grabber Closed (in.)	204	204	204	204	204	204	204	204	204	204	204	204	204	204	204
I. Overall Width, Arm Out (LONG REACH), Grabber Closed (in.)	240	240	240	240	240	240	240	240	240	240	240	240	240	240	240
J. Overall Width, Arm In, Grabber Closed (in.)	134	134	134	134	134	134	134	134	134	134	134	134	134	134	134
K. Overall Width, Arm In, Grabber Open (in.)	102	102	102	102	102	102	102	102	102	102	102	102	102	102	102
L. Distance between bottom of Grabber & chassis frame rail (in.)	22/28	22/28	22/28	22/28	22/28	22/28	22/28	22/28	22/28	22/28	22/28	22/28	22/28	22/28	22/28